

| CURRENT OWNER | | TOPO | UTILITIES | STRT / ROAD | LOCATION | CURRENT ASSESSMENT | | | | | |
|--|--|---|-----------|----------------------|----------|--------------------|---------|-------------|------|-----------|----------|
| ODONOVAN MICHAEL HUGH ODONOVAN JULIE ANNA 596 MAYFLOWER ST DUXBURY MA 02332 | | 0 | Water | 0 | Arterial | 0 | Average | Description | Code | Appraised | Assessed |
| | | 0 | No Sewer | 0 | Paved | 0 | Average | RESIDNTL | 1010 | 215,100 | 215,100 |
| | | SUPPLEMENTAL DATA | | Cyclical Exemption W | | 4 | | RES LAND | 1010 | 358,100 | 358,100 |
| | | Alt Prcl ID Scnd Home Tax Class T Tot Fin Area 2044 Total Acres 1.148 Chapter Lan GIS ID F_868982_2840345 | | District Res Exem | | | | RESIDNTL | 1010 | 1,600 | 1,600 |
| | | | | Assoc Pid# | | | | Total | | 574,800 | 574,800 |

905
 DUXBURY, MA
VISION

| RECORD OF OWNERSHIP | | BK-VOL/PAGE | SALE DATE | Q/U | V/I | SALE PRICE | VC | PREVIOUS ASSESSMENTS (HISTORY) | | | | | |
|-----------------------|--|-------------|------------|-----|-----|------------|----|--------------------------------|------|----------|-------|------|----------|
| ODONOVAN MICHAEL HUGH | | 15423 0093 | 08-25-1997 | U | I | 1 | 1F | Year | Code | Assessed | Year | Code | Assessed |
| | | | | | | | | 2023 | 1010 | 187,100 | 2022 | 1010 | 168,400 |
| | | | | | | | | | 1010 | 372,400 | | 1010 | 306,900 |
| | | | | | | | | | 1010 | 1,100 | | 1010 | 1,100 |
| | | | | | | | | Total | | 560,600 | Total | | 476,400 |
| | | | | | | | | | | | Total | | 405,800 |

| EXEMPTIONS | | | OTHER ASSESSMENTS | | | | | |
|------------|------|-------------|-------------------|------|-------------|--------|--------|----------|
| Year | Code | Description | Amount | Code | Description | Number | Amount | Comm Int |
| | | | | | | | | |
| Total | | | 0.00 | | | | | |

This signature acknowledges a visit by a Data Collector or Assessor

| APPRAISED VALUE SUMMARY | |
|-------------------------------|---------|
| Appraised Bldg. Value (Card) | 215,100 |
| Appraised Xf (B) Value (Bldg) | 0 |
| Appraised Ob (B) Value (Bldg) | 1,600 |
| Appraised Land Value (Bldg) | 358,100 |
| Special Land Value | 0 |
| Total Appraised Parcel Value | 574,800 |
| Valuation Method | C |
| Total Appraised Parcel Value | 574,800 |

| ASSESSING NEIGHBORHOOD | | | |
|------------------------|-----------|---|---------|
| Nbhd | Nbhd Name | B | Tracing |
| 0050 | | | |

| NOTES | | | | | | | | | |
|-------|--|--|--|--|--|--|--|--|--|
| | | | | | | | | | |

| BUILDING PERMIT RECORD | | | | | | | | VISIT / CHANGE HISTORY | | | | | | |
|------------------------|------------|------|-------------|--------|------------|--------|-----------|------------------------|------------|-----|------|----|----|--------------------|
| Permit Id | Issue Date | Type | Description | Amount | Insp Date | % Comp | Date Comp | Comments | Date | Id | Type | Is | Cd | Purpose/Result |
| 11 | 03-17-2008 | MN | Maintenance | 7,000 | | 100 | | REROOF 20 SQUARES | 09-28-2020 | SJT | 10 | | 01 | Measure - No Entry |
| 12561 | 10-07-1992 | MN | Maintenance | | | 100 | | INSTLARROW STOVE | 04-12-2013 | VGS | | | 20 | Field Review |
| 12076 | 10-22-1991 | RM | Remodel | | | 100 | | INSTALL WOOD STOVE | 03-01-2008 | BSB | | 1 | 00 | Measure & Listed |
| 11695 | 08-29-1990 | AD | Addition | 1,500 | 01-01-1992 | 100 | | WOOD DECK 16 X 8 | | | | | | |

| LAND LINE VALUATION SECTION | | | | | | | | | | | | | | | | |
|-----------------------------|----------|---------------|------|-----------|------------|------------------------|----------|------------|-------|-------|-----------|------------------|---------------------|------------|------------|---------|
| B | Use Code | Description | Zone | Land Type | Land Units | Unit Price | Size Adj | Site Index | Cond. | Nbhd. | Nbhd. Adj | Notes | Location Adjustment | Adj Unit P | Land Value | |
| 1 | 1010 | Single Family | RC | Primary | 40,000 SF | 8.75 | 1.00000 | 5 | 1.00 | 0050 | 1.000 | | | 1.0000 | 8.75 | 350,000 |
| 1 | 1010 | Single Family | RC | Residual | 0.230 AC | 35,000.00 | 1.00000 | 5 | 1.00 | 0050 | 1.000 | | | 1.0125 | 0.81 | 8,100 |
| Total Card Land Units | | | | | 1.15 AC | Parcel Total Land Area | | | | | 1.15 | Total Land Value | | | 358,100 | |

| CONSTRUCTION DETAIL | | | CONSTRUCTION DETAIL (CONTINUED) | | |
|---------------------|------|----------------|---------------------------------|------|-------------|
| Element | Cd | Description | Element | Cd | Description |
| Style | 07 | Contemporary | Bsmt Area | 1162 | |
| Model | 01 | Residential | Bsmt Type | 04 | |
| Grade | 03 | Average | Unfin Area | 0.00 | Full |
| Stories | 2 | | | | |
| Occupancy | 1 | | CONDO DATA | | |
| Exterior Wall 1 | 25 | Vinyl Siding | Parcel Id | | C |
| Exterior Wall 2 | | | | | B |
| Roof Structure | 03 | Gable | Adjust Type | Code | Description |
| Roof Cover | 03 | Asphalt | Condo Flr | | |
| Interior Wall 1 | 05 | Drywall | Condo Unit | | |
| Interior Wall 2 | | | COST / MARKET VALUATION | | |
| Interior Floor 1 | 12 | Hardwood | | | 281,722 |
| Interior Floor 2 | | | Net Other Adj | | 13,000 |
| Heat Fuel | 02 | Oil | Replace Cost | | 294,722 |
| Heat Type | 04 | Forced Air-Duc | Year Built | | 1978 |
| AC Type | 03 | Central | Effective Year Built | | 1994 |
| Bedrooms | 3 | | Depreciation Code | | A |
| Full Baths | 2 | | Remodel Rating | | |
| Half Baths | 0 | | Year Remodeled | | |
| Extra Fixtures | 0 | | Depreciation % | | 27 |
| Total Rooms | 6 | | Functional Obsol | | |
| Bath Style | 02 | Average | External Obsol | | |
| Kitchen Style | 02 | Average | Trend Factor | | 1.000 |
| Extra Kitchens | 0 | | Condition | | |
| Fireplaces | 1 | | Condition % | | |
| Extra Openings | 0 | | Percent Good | | 73 |
| Gas Fireplaces | 0 | | Cns Sect Rcnld | | 215,100 |
| Sq Ft Fin Bsmt | 0 | | Dep % Ovr | | |
| FBM Quality | | | Dep Ovr Comment | | |
| Foundation | 06 | Poured Conc | Misc Imp Ovr | | |
| Bsmt Garage | 0 | | Misc Imp Ovr Comment | | |
| Bsmt Area | 1162 | | Cost to Cure Ovr | | |
| | | | Cost to Cure Ovr Comment | | |

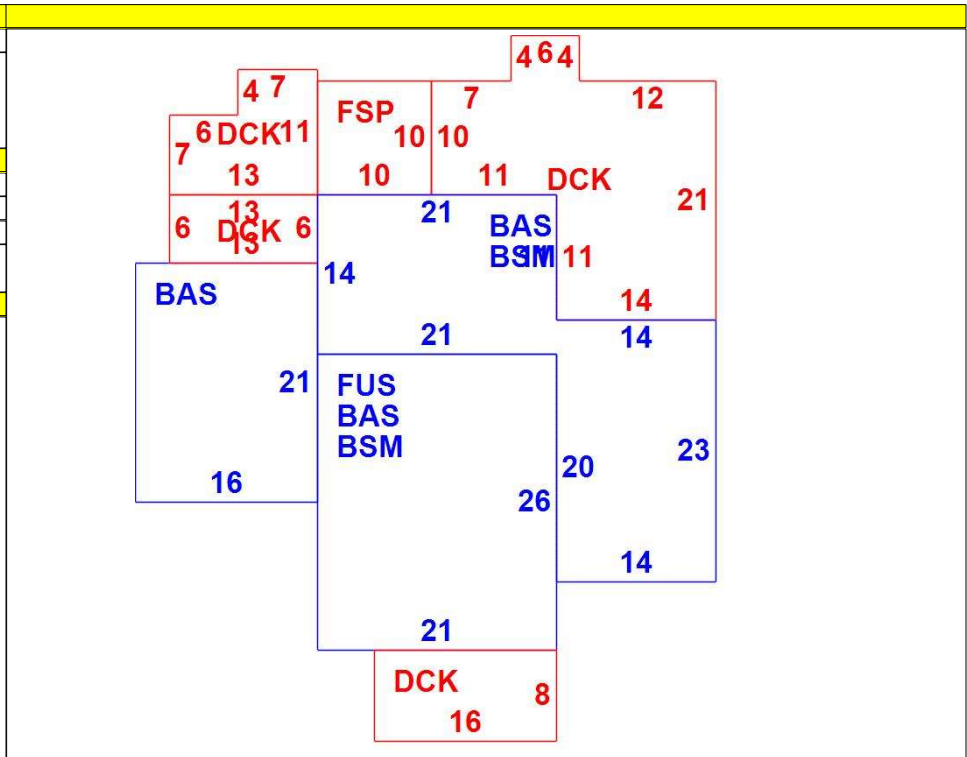

| OB - OUTBUILDING & YARD ITEMS(L) / XF - BUILDING EXTRA FEATURES(B) | | | | | | | | | | |
|--|-------------|-----|-------|------------|--------|----------|------|-------|------------|-------------|
| Code | Description | L/B | Units | Unit Price | Yr Blt | Cond. Cd | % Gd | Grade | Grade Adj. | Appr. Value |
| SHD1 | Shed | L | 64 | 21.00 | 1985 | F | 55 | C | 1.00 | 700 |
| SHD1 | Shed | L | 64 | 21.00 | 2010 | A | 70 | C | 1.00 | 900 |

| BUILDING SUB-AREA SUMMARY SECTION | | | | | | |
|-----------------------------------|----------------------|-------------|------------|----------|-----------|----------------|
| Code | Description | Living Area | Floor Area | Eff Area | Unit Cost | Undeprec Value |
| BAS | First Floor | 1,498 | 1,498 | 1,498 | 118.82 | 177,992 |
| BSM | Basement | 0 | 1,162 | 232 | 23.72 | 27,566 |
| DCK | Deck | 0 | 753 | 75 | 11.83 | 8,912 |
| FSP | Screened Porch | 0 | 100 | 20 | 23.76 | 2,376 |
| FUS | Finished Upper Story | 546 | 546 | 546 | 118.82 | 64,876 |
| Ttl Gross Liv / Lease Area | | 2,044 | 4,059 | 2,371 | | 281,722 |

