

CURRENT OWNER		TOPO	UTILITIES	STRT / ROAD	LOCATION	CURRENT ASSESSMENT			
SHERMAN CHRISTOPHER P			0 Water	0 Subdivision	0 Average	Description	Code	Appraised	Assessed
SHERMAN MARY ALISA			0 No Sewer	0 Paved	0 Average	RESIDNTL	1010	743,700	743,700
92 HOUNDS DITCH LN		SUPPLEMENTAL DATA				RES LAND	1010	539,200	539,200
DUXBURY MA 02332		Alt Prcl ID Scnd Home Tax Class T Tot Fin Area 2926 Total Acres 1.167 Chapter Lan GIS ID F_874938_2840696		Cyclical 5 Exemption W District Res Exem Assoc Pid#					
						Total		1,282,900	1,282,900

905
 DUXBURY, MA
VISION

RECORD OF OWNERSHIP		BK-VOL/PAGE	SALE DATE	Q/U	V/I	SALE PRICE	VC	PREVIOUS ASSESSMENTS (HISTORY)					
SHERMAN CHRISTOPHER P		15308 0303	07-09-1997	Q	I	328,500	00	Year	Code	Assessed	Year	Code	Assessed
WOLLEY CHARLES S		14472 0281	06-28-1996	Q	I	321,000	00	2023	1010	566,500	2022	1010	518,600
BUCKLEY KEVIN G		13291 0172	12-01-1994	Q	I	322,000	00		1010	641,300		1010	503,100
CLARK ROBERT J		10584 0003	09-14-1991	Q	I	250,000	00	Total		1,207,800	Total		1,021,700
								Total		873,100	Total		873,100

EXEMPTIONS			OTHER ASSESSMENTS					
Year	Code	Description	Amount	Code	Description	Number	Amount	Comm Int
Total		0.00						

This signature acknowledges a visit by a Data Collector or Assessor

ASSESSING NEIGHBORHOOD			
Nbhd	Nbhd Name	B	Tracing
0080			Batch

APPRAISED VALUE SUMMARY	
Appraised Bldg. Value (Card)	743,700
Appraised Xf (B) Value (Bldg)	0
Appraised Ob (B) Value (Bldg)	0
Appraised Land Value (Bldg)	539,200
Special Land Value	0
Total Appraised Parcel Value	1,282,900
Valuation Method	C
Total Appraised Parcel Value	1,282,900

BUILDING PERMIT RECORD										VISIT / CHANGE HISTORY					
Permit Id	Issue Date	Type	Description	Amount	Insp Date	% Comp	Date Comp	Comments		Date	Id	Type	Is	Cd	Purpose/Result
19990502	10-27-1999	AD	Addition	60,000	05-14-2001	100		1-STY AD & PORCH		11-15-2019	SJT	10		01	Measure - No Entry
12170	12-23-1991	RM	Remodel	8,500	01-01-1992	100		2RMS ATTIC 36 X 14		09-10-2018	SJD			20	Field Review
										04-12-2013	VGS			20	Field Review
										05-14-2001	KP	1	00		Measure & Listed

LAND LINE VALUATION SECTION															
B	Use Code	Description	Zone	Land Type	Land Units	Unit Price	Size Adj	Site Index	Cond.	Nbhd.	Nbhd. Adj	Notes	Location Adjustment	Adj Unit P	Land Value
1	1010	Single Family	PD	Primary	40,000 SF	8.75	1.00000	5	1.00	0080	1.503			13.15	526,100
1	1010	Single Family	PD	Residual	0.250 AC	35,000.00	1.00000	5	1.00	0080	1.503			1.20	13,100
Total Card Land Units					1.17 AC	Parcel Total Land Area					1.17	Total Land Value			539,200

CONSTRUCTION DETAIL				CONSTRUCTION DETAIL (CONTINUED)			
Element	Cd	Description	Element	Cd	Description		
Style	03	Colonial	Bsmt Area	1160			
Model	01	Residential	Bsmt Type	04			
Grade	08	Excellent	Unfin Area	0.00	Full		
Stories	2						
Occupancy	1						
Exterior Wall 1	14	Wood Shingle					
Exterior Wall 2	11	Clapboard					
Roof Structure	03	Gable					
Roof Cover	10	Wood Shingle					
Interior Wall 1	05	Drywall					
Interior Wall 2							
Interior Floor 1	12	Hardwood					
Interior Floor 2							
Heat Fuel	02	Oil					
Heat Type	05	Hot Water					
AC Type	01	None					
Bedrooms	5						
Full Baths	3						
Half Baths	1						
Extra Fixtures	2						
Total Rooms	12						
Bath Style	02	Average					
Kitchen Style	02	Average					
Extra Kitchens	0						
Fireplaces	2						
Extra Openings	0						
Gas Fireplaces	0						
Sq Ft Fin Bsmt	0						
FBM Quality							
Foundation	06	Poured Conc					
Bsmt Garage	3						
Bsmt Area	1160						

CONDO DATA			
Parcel Id	C	Owne	
		B	S
Adjust Type	Code	Description	Factor%
Condo Flr			
Condo Unit			

COST / MARKET VALUATION			
Net Other Adj		790,970	
Replace Cost		44,625	
Year Built		1990	
Effective Year Built		2010	
Depreciation Code		E	
Remodel Rating			
Year Remodeled			
Depreciation %		11	
Functional Obsol			
External Obsol			
Trend Factor		1.000	
Condition			
Condition %			
Percent Good		89	
Cns Sect Rcnd		743,700	
Dep % Ovr			
Dep Ovr Comment			
Misc Imp Ovr			
Misc Imp Ovr Comment			
Cost to Cure Ovr			
Cost to Cure Ovr Comment			

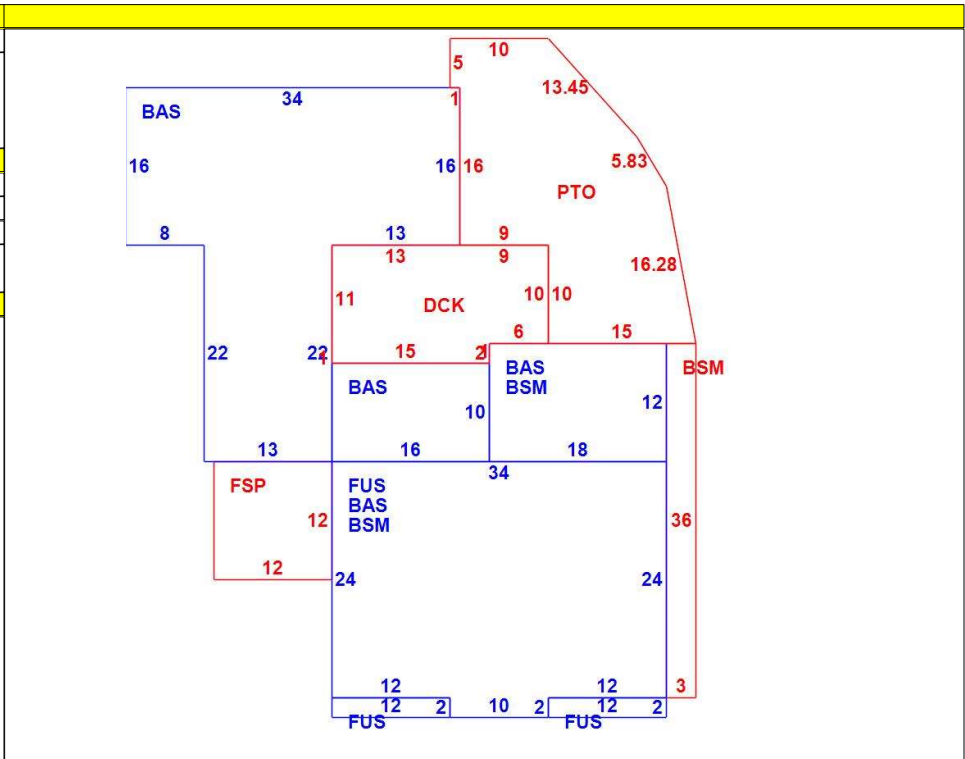

OB - OUTBUILDING & YARD ITEMS(L) / XF - BUILDING EXTRA FEATURES(B)										
Code	Description	L/B	Units	Unit Price	Yr Blt	Cond. Cd	% Gd	Grade	Grade Adj.	Appr. Value

BUILDING SUB-AREA SUMMARY SECTION						
Code	Description	Living Area	Floor Area	Eff Area	Unit Cost	Undeprec Value
BAS	First Floor	2,042	2,042	2,042	244.35	498,968
BSM	Basement	0	1,160	232	48.87	56,690
DCK	Deck	0	252	25	24.24	6,109
FSP	Screened Porch	0	144	29	49.21	7,086
FUS	Finished Upper Story	884	884	884	244.35	216,008
PTO	Patio	0	508	25	12.03	6,109
Ttl Gross Liv / Lease Area		2,926	4,990	3,237		790,970

