

CONSTRUCTION DETAIL			CONSTRUCTION DETAIL (CONTINUED)		
Element	Cd	Description	Element	Cd	Description
Style	01	Ranch	Bsmt Area	1296	
Model	01	Residential	Bsmt Type	03	
Grade	06	Good	Unfin Area	0.00	Partial
Stories	1				
Occupancy	1				
Exterior Wall 1	11	Clapboard			
Exterior Wall 2	14	Wood Shingle			
Roof Structure	03	Gable			
Roof Cover	03	Asphalt			
Interior Wall 1	05	Drywall			
Interior Wall 2					
Interior Floor 1	12	Hardwood			
Interior Floor 2					
Heat Fuel	03	Gas			
Heat Type	05	Hot Water			
AC Type	06	Partial			
Bedrooms	4				
Full Baths	2				
Half Baths	1				
Extra Fixtures	3				
Total Rooms	7				
Bath Style	03	Modern			
Kitchen Style	03	Modern			
Extra Kitchens	0				
Fireplaces	2				
Extra Openings	0				
Gas Fireplaces	0				
Sq Ft Fin Bsmt	676				
FBM Quality	05	Living Area			
Foundation	05	Conc Block			
Bsmt Garage	0				
Bsmt Area	1296				

CONDO DATA			
Parcel Id	C	Owne	S
Adjust Type	Code	Description	Factor%
Condo Flr			
Condo Unit			

COST / MARKET VALUATION	
Net Other Adj	485,744
Replace Cost	54,810
Year Built	1955
Effective Year Built	2006
Depreciation Code	E
Remodel Rating	
Year Remodeled	
Depreciation %	15
Functional Obsol	
External Obsol	
Trend Factor	1.000
Condition	
Condition %	
Percent Good	85
Cns Sect Rcnld	459,500
Dep % Ovr	
Dep Ovr Comment	
Misc Imp Ovr	
Misc Imp Ovr Comment	
Cost to Cure Ovr	
Cost to Cure Ovr Comment	

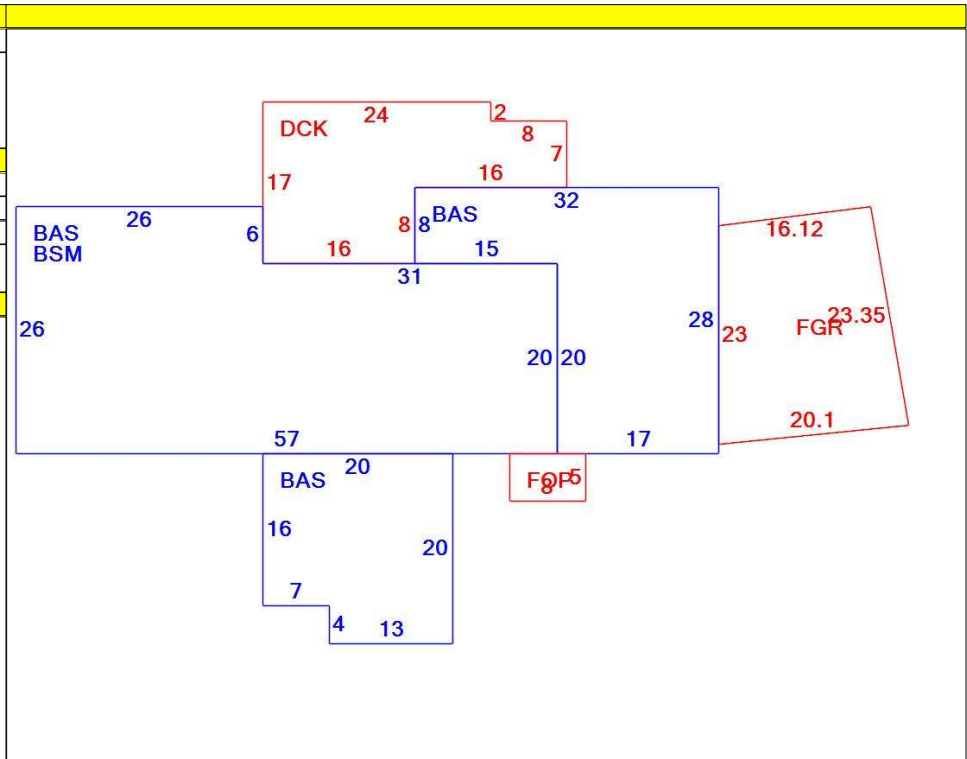

OB - OUTBUILDING & YARD ITEMS(L) / XF - BUILDING EXTRA FEATURES(B)

Code	Description	L/B	Units	Unit Price	Yr Blt	Cond. Cd	% Gd	Grade	Grade Adj.	Appr. Value
SHD1	Shed	L	150	21.00	1980	F	55	C	1.00	1,700
SHD1	Shed	L	150	21.00	1980	F	55	C	1.00	1,700
FSP	Screen Porch	L	100	39.00	1980	F	55	C	1.00	2,100
SLR	Solar Panels	L	32	1050.00	2017	E	100	B	1.50	0

BUILDING SUB-AREA SUMMARY SECTION

Code	Description	Living Area	Floor Area	Eff Area	Unit Cost	Undeprec Value
BAS	First Floor	2,264	2,264	2,264	177.54	401,946
BSM	Basement	0	1,296	259	35.48	45,982
DCK	Deck	0	400	40	17.75	7,102
FGR	Garage	0	418	167	70.93	29,649
FOP	Open Porch	0	40	6	26.63	1,065
Ttl Gross Liv / Lease Area		2,264	4,418	2,736		485,744

