

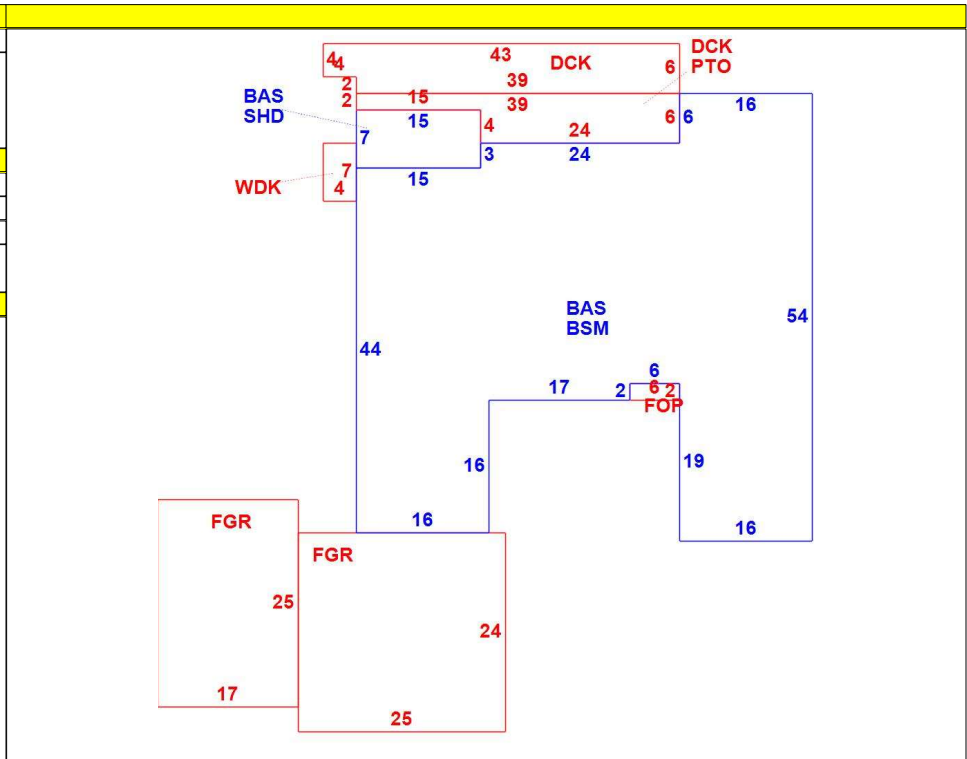

CONSTRUCTION DETAIL			CONSTRUCTION DETAIL (CONTINUED)		
Element	Cd	Description	Element	Cd	Description
Style	01	Ranch	Bsmt Area	2377	
Model	01	Residential	Bsmt Type	04	
Grade	08	Excellent	Unfin Area	0.00	Full
Stories	1				
Occupancy	1				
Exterior Wall 1	11	Clapboard			
Exterior Wall 2					
Roof Structure	03	Gable			
Roof Cover	03	Asphalt			
Interior Wall 1	05	Drywall			
Interior Wall 2					
Interior Floor 1	12	Hardwood			
Interior Floor 2					
Heat Fuel	03	Gas			
Heat Type	05	Hot Water			
AC Type	03	Central			
Bedrooms	4				
Full Baths	3				
Half Baths	1				
Extra Fixtures	4				
Total Rooms	8				
Bath Style	03	Modern			
Kitchen Style	03	Modern			
Extra Kitchens	0				
Fireplaces	1				
Extra Openings	1				
Gas Fireplaces	1				
Sq Ft Fin Bsmt	2120				
FBM Quality	05	Living Area			
Foundation	06	Poured Conc			
Bsmt Garage	0				
Bsmt Area	2377				

CONDO DATA			
Parcel Id		C	Owne
			B S
Adjust Type	Code	Description	Factor%
Condo Flr			
Condo Unit			

COST / MARKET VALUATION	
Net Other Adj	691,856
Replace Cost	135,800
Year Built	827,655
Effective Year Built	1975
Depreciation Code	2008
Remodel Rating	E
Year Remodeled	04
Depreciation %	2013
Functional Obsol	13
External Obsol	
Trend Factor	1.000
Condition	
Condition %	
Percent Good	87
Cns Sect Rcnld	720,100
Dep % Ovr	
Dep Ovr Comment	
Misc Imp Ovr	
Misc Imp Ovr Comment	
Cost to Cure Ovr	
Cost to Cure Ovr Comment	



**OB - OUTBUILDING & YARD ITEMS(L) / XF - BUILDING EXTRA FEATURES(B)**

Code	Description	L/B	Units	Unit Price	Yr Blt	Cond. Cd	% Gd	Grade	Grade Adj.	Appr. Value
SPL2	Ing Pool-Good	L	640	89.00	1995	A	70	C	1.00	39,900
SHD1	Shed	L	96	21.00	1991	A	70	C	1.00	1,400
DCK	Dock	L	500	45.00	1980	A	70	C	1.00	15,800

**BUILDING SUB-AREA SUMMARY SECTION**

Code	Description	Living Area	Floor Area	Eff Area	Unit Cost	Undeprec Value
BAS	First Floor	2,377	2,377	2,377	207.52	493,263
BSM	Basement	0	2,272	454	41.47	94,212
DCK	Deck	0	424	42	20.56	8,716
FGR	Garage	0	1,025	410	83.01	85,081
FOP	Open Porch	0	12	2	34.59	415
PTO	Patio	0	174	9	10.73	1,868
SHD	Attached Shed	0	105	37	73.12	7,678
WDK	Deck	0	28	3	22.23	623
Ttl Gross Liv / Lease Area		2,377	6,417	3,334		691,856

