

CURRENT OWNER		TOPO	UTILITIES	STRT / ROAD	LOCATION	CURRENT ASSESSMENT			
OATES CHRISTOPHER M TT			0 Water	0 Subdivision	0 Average	Description	Code	Appraised	Assessed
NANCY E OATES FAMILY TRUST 202			0 No Sewer	0 Paved	0 Average	RESIDNTL	1010	559,100	559,100
42 ST PAUL STREET				0 Light		RES LAND	1010	484,300	484,300
SUPPLEMENTAL DATA									
BROOKLINE MA 02446		Alt Prcl ID	Scnd Home FAMILY OCCUPIED		Cyclical Exemption	7			
		Tax Class	T		W				
		Tot Fin Area	2470		District				
		Total Acres	.23		Res Exem				
		Chapter Lan							
		GIS ID	F_871465_2831533		Assoc Pid#				
Total								1,043,400	1,043,400

905
 DUXBURY, MA
VISION

RECORD OF OWNERSHIP		BK-VOL/PAGE	SALE DATE	Q/U	V/I	SALE PRICE	VC	PREVIOUS ASSESSMENTS (HISTORY)						
OATES CHRISTOPHER M TT		56028 296	11-17-2021	U	I	1	1A	Year	Code	Assessed	Year	Code	Assessed	
OATES NANCY E		16501 0325	08-13-1998	U	V	110,000	1	2023	1010	417,900	2022	1010	357,000	
OLDE KINGS LLC		16501 0323	08-13-1998	U	V	95,000	1P		1010	377,700	2021	1010	331,600	
Total									795,600			688,600		613,000

EXEMPTIONS			OTHER ASSESSMENTS					
Year	Code	Description	Amount	Code	Description	Number	Amount	Comm Int
Total			0.00					

This signature acknowledges a visit by a Data Collector or Assessor

APPRAISED VALUE SUMMARY	
Appraised Bldg. Value (Card)	559,100
Appraised Xf (B) Value (Bldg)	0
Appraised Ob (B) Value (Bldg)	0
Appraised Land Value (Bldg)	484,300
Special Land Value	0
Total Appraised Parcel Value	1,043,400
Valuation Method	C
Total Appraised Parcel Value	1,043,400

ASSESSING NEIGHBORHOOD			
Nbhd	Nbhd Name	B	Tracing
0040			

NOTES													

BUILDING PERMIT RECORD								VISIT / CHANGE HISTORY						
Permit Id	Issue Date	Type	Description	Amount	Insp Date	% Comp	Date Comp	Comments	Date	Id	Type	Is	Cd	Purpose/Result
462	10-05-2005	MN	Maintenance	5,500	09-26-2006	100		OVER GARAGE/WINDOW	10-29-2019	SJT	10		12	Property Est. - No Access
401	10-09-2001	AD	Addition	6,000	10-22-2002	100		10X12 1 STORY ADD	04-12-2013	VGS			20	Field Review
15314	02-09-1999	AD	Addition	2,500	05-17-2000	100		AD DECK	12-21-2010	K-D		1	00	Measure & Listed
15082	08-18-1998	NC	New Construct	116,000	05-17-2000	100		2 STY						

LAND LINE VALUATION SECTION																
B	Use Code	Description	Zone	Land Type	Land Units	Unit Price	Size Adj	Site Index	Cond.	Nbhd.	Nbhd. Adj	Notes	Location Adjustment	Adj Unit P	Land Value	
1	1010	Single Family	RC	Primary	10,019 SF	26.56	1.00000	5	1.00	0040	1.820		1.0000	48.34	484,300	
Total Card Land Units					0.23	AC	Parcel Total Land Area					0.23	Total Land Value			484,300

CONSTRUCTION DETAIL **CONSTRUCTION DETAIL (CONTINUED)**

Element	Cd	Description	Element	Cd	Description
Style	04	Cape Cod	Bsmt Area	1256	
Model	01	Residential	Bsmt Type	04	
Grade	06	Good	Unfin Area	0.00	Full
Stories	1.85				
Occupancy	1		CONDO DATA		
Exterior Wall 1	25	Vinyl Siding	Parcel Id		C
Exterior Wall 2					B
Roof Structure	02	Shed	Adjust Type	Code	Description
Roof Cover	03	Asphalt	Condo Flr		
Interior Wall 1	05	Drywall	Condo Unit		
Interior Wall 2			COST / MARKET VALUATION		
Interior Floor 1	12	Hardwood	Net Other Adj		613,980
Interior Floor 2			Replace Cost		28,710
Heat Fuel	03	Gas	Year Built		642,690
Heat Type	05	Hot Water	Effective Year Built		1998
AC Type	03	Central	Depreciation Code		2008
Bedrooms	4		Remodel Rating		G
Full Baths	3		Year Remodeled		
Half Baths	0		Depreciation %		13
Extra Fixtures	1		Functional Obsol		
Total Rooms	9		External Obsol		
Bath Style	02	Average	Trend Factor		1.000
Kitchen Style	02	Average	Condition		
Extra Kitchens	0		Condition %		
Fireplaces	2		Percent Good		87
Extra Openings	0		Cns Sect Rcnd		559,100
Gas Fireplaces	0		Dep % Ovr		
Sq Ft Fin Bsmt	0		Dep Ovr Comment		
FBM Quality			Misc Imp Ovr		
Foundation	06	Poured Conc	Misc Imp Ovr Comment		
Bsmt Garage	0		Cost to Cure Ovr		
Bsmt Area	1256		Cost to Cure Ovr Comment		

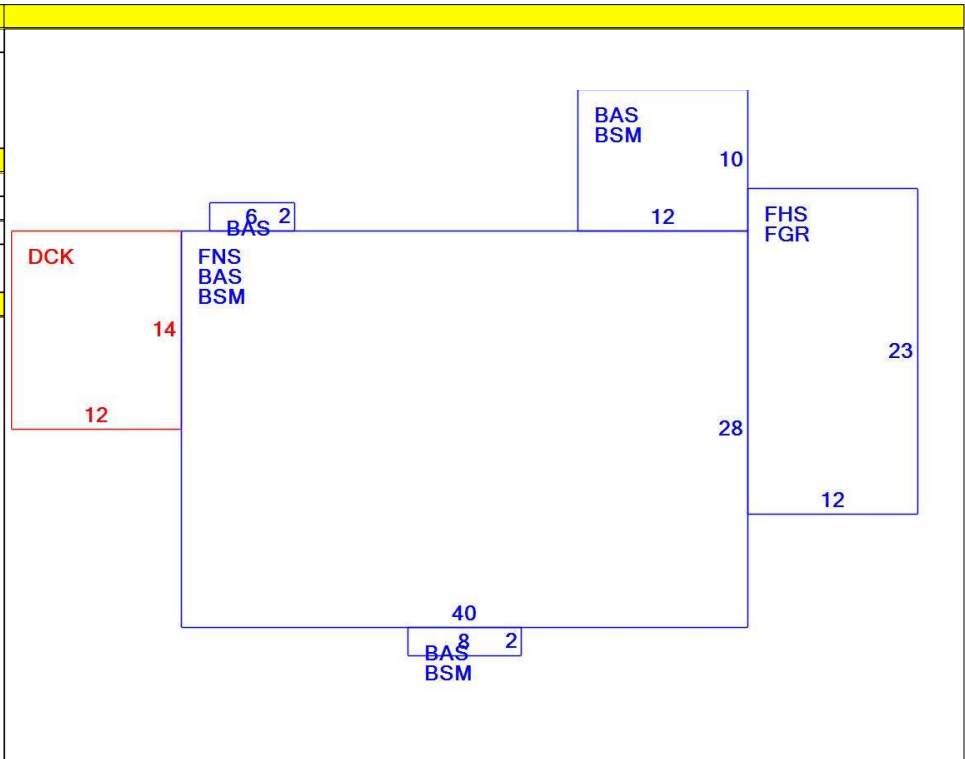

OB - OUTBUILDING & YARD ITEMS(L) / XF - BUILDING EXTRA FEATURES(B)

Code	Description	L/B	Units	Unit Price	Yr Blt	Cond. Cd	% Gd	Grade	Grade Adj.	Appr. Value

BUILDING SUB-AREA SUMMARY SECTION

Code	Description	Living Area	Floor Area	Eff Area	Unit Cost	Undeprec Value
BAS	First Floor	1,268	1,268	1,268	219.91	278,842
BSM	Basement	0	1,256	251	43.95	55,197
DCK	Deck	0	168	17	22.25	3,738
FGR	Garage	0	276	110	87.64	24,190
FHS	Finished Half Story	138	276	138	109.95	30,347
FNS	Finished 90% Story	1,008	1,120	1,008	197.92	221,666
Ttl Gross Liv / Lease Area		2,414	4,364	2,792		613,980

