

| CURRENT OWNER | | TOPO | UTILITIES | STRT / ROAD | LOCATION | CURRENT ASSESSMENT | | | |
|------------------------------|--|--------------------------|------------|---------------|------------|--------------------|-------|-----------|----------|
| GOOLEY DAVID M | | | 0 Water | 0 Subdivision | 0 Average | Description | Code | Appraised | Assessed |
| CHAMBERLIN-GOOLEY DIANE MARY | | | 0 No Sewer | 0 Paved | 0 Average | RESIDNTL | 1010 | 422,200 | 422,200 |
| 8 MAYFLOWER RD | | SUPPLEMENTAL DATA | | | 0 Light | RES LAND | 1010 | 447,700 | 447,700 |
| DUXBURY MA 02332 | | Alt Prcl ID | | | Cyclical 7 | RESIDNTL | 1010 | 2,100 | 2,100 |
| | | Scnd Home | | | Exemption | | | | |
| | | Tax Class T | | | W | | | | |
| | | Tot Fin Area 2112 | | | District | | | | |
| | | Total Acres .172 | | | Res Exem | | | | |
| | | Chapter Lan | | | | | | | |
| | | GIS ID F_871464_2830903 | | | Assoc Pid# | | | | |
| | | | | | | | Total | 872,000 | 872,000 |

VISION

| RECORD OF OWNERSHIP | | BK-VOL/PAGE | SALE DATE | Q/U | V/I | SALE PRICE | VC | PREVIOUS ASSESSMENTS (HISTORY) | | | | | |
|---------------------|--|-------------|------------|-----|-----|------------|-------|--------------------------------|-------|----------|-------|---------|----------|
| GOOLEY DAVID M | | 30923 0047 | 07-14-2005 | U | I | 1 | 1F | Year | Code | Assessed | Year | Code | Assessed |
| GOOLEY DAVID M | | 30923 0030 | 07-14-2005 | Q | I | 266,000 | 00 | 2023 | 1010 | 324,200 | 2022 | 1010 | 297,700 |
| | | | | | | | | | 1010 | 335,700 | | 1010 | 294,500 |
| | | | | | | | | | 1010 | 1,200 | | 1010 | 1,200 |
| | | | | | | | Total | 661,100 | Total | 593,400 | Total | 511,300 | |

| EXEMPTIONS | | | OTHER ASSESSMENTS | | | | | |
|------------|------|-------------|-------------------|------|-------------|--------|--------|----------|
| Year | Code | Description | Amount | Code | Description | Number | Amount | Comm Int |
| | | Total | 0.00 | | | | | |

This signature acknowledges a visit by a Data Collector or Assessor

| ASSESSING NEIGHBORHOOD | | | | APPRAISED VALUE SUMMARY | |
|------------------------|-----------|---|---------|-------------------------|-------------------------------|
| Nbhd | Nbhd Name | B | Tracing | Batch | |
| 0040 | | | | | |
| NOTES | | | | | |
| | | | | | Appraised Bldg. Value (Card) |
| | | | | | 422,200 |
| | | | | | Appraised Xf (B) Value (Bldg) |
| | | | | | 0 |
| | | | | | Appraised Ob (B) Value (Bldg) |
| | | | | | 2,100 |
| | | | | | Appraised Land Value (Bldg) |
| | | | | | 447,700 |
| | | | | | Special Land Value |
| | | | | | 0 |
| | | | | | Total Appraised Parcel Value |
| | | | | | 872,000 |
| | | | | | Valuation Method |
| | | | | | C |
| | | | | | Total Appraised Parcel Value |
| | | | | | 872,000 |

| BUILDING PERMIT RECORD | | | | | | | | VISIT / CHANGE HISTORY | | | | | | |
|------------------------|------------|------|---------------|--------|-----------|--------|-----------|------------------------|------------|-----|------|----|----|--------------------|
| Permit Id | Issue Date | Type | Description | Amount | Insp Date | % Comp | Date Comp | Comments | Date | Id | Type | Is | Cd | Purpose/Result |
| 125 | 08-08-2011 | MN | Maintenance | 400 | | 100 | | 2 WINDOWS | 11-14-2019 | SJT | 10 | | 00 | Measure & Listed |
| 232 | 11-23-2009 | NC | New Construct | 1,200 | | 100 | | RPL DECK W/8X9DECK | 04-12-2013 | VGS | | | 20 | Field Review |
| 149 | 08-12-2009 | AD | Addition | 17,000 | | 100 | | 288'2ND STY ADD | 07-27-2007 | KP | | 4 | 01 | Measure - No Entry |
| 437 | 12-06-2006 | AD | Addition | 30,000 | | 100 | | 10X22 2 STY ADD | | | | | | |
| 410 | 11-16-2006 | DM | Demolish | 11,000 | | 100 | | DWELLING | | | | | | |
| 112 | 04-05-2006 | AD | Addition | 85,000 | | 100 | | 18.5X32 ON FOUNDATIO | | | | | | |
| 66 | 03-02-2006 | DM | Demolish | 10,000 | | 100 | | 8X8 SEC DWELL/FOUNDA | | | | | | |

| LAND LINE VALUATION SECTION | | | | | | | | | | | | | | | |
|-----------------------------|----------|---------------|------|-----------|------------|------------------------|----------|------------|-------|-------|-----------|------------------|---------------------|------------|------------|
| B | Use Code | Description | Zone | Land Type | Land Units | Unit Price | Size Adj | Site Index | Cond. | Nbhd. | Nbhd. Adj | Notes | Location Adjustment | Adj Unit P | Land Value |
| 1 | 1010 | Single Family | RC | Primary | 7,500 SF | 32.80 | 1.00000 | 5 | 1.00 | 0040 | 1.820 | | 1.0000 | 59.69 | 447,700 |
| Total Card Land Units | | | | | 0.17 AC | Parcel Total Land Area | | | | | 0.17 | Total Land Value | | | 447,700 |

| CONSTRUCTION DETAIL | | | CONSTRUCTION DETAIL (CONTINUED) | | |
|---------------------|-----|----------------|---------------------------------|------|-------------|
| Element | Cd | Description | Element | Cd | Description |
| Style | 03 | Colonial | Bsmt Area | 776 | |
| Model | 01 | Residential | Bsmt Type | 04 | |
| Grade | 06 | Good | Unfin Area | 0.00 | Full |
| Stories | 2 | | | | |
| Occupancy | 1 | | CONDO DATA | | |
| Exterior Wall 1 | 14 | Wood Shingle | Parcel Id | | C |
| Exterior Wall 2 | 11 | Clapboard | | | B |
| Roof Structure | 03 | Gable | Adjust Type | Code | Description |
| Roof Cover | 03 | Asphalt | Condo Flr | | |
| Interior Wall 1 | 05 | Drywall | Condo Unit | | |
| Interior Wall 2 | | | COST / MARKET VALUATION | | |
| Interior Floor 1 | 12 | Hardwood | Net Other Adj | | 533,272 |
| Interior Floor 2 | 11 | Ceramic | Replace Cost | | 45,023 |
| Heat Fuel | 03 | Gas | Year Built | | 578,294 |
| Heat Type | 04 | Forced Air-Duc | Effective Year Built | | 1950 |
| AC Type | 03 | Central | Depreciation Code | | 1994 |
| Bedrooms | 3 | | Remodel Rating | | G |
| Full Baths | 2 | | Year Remodeled | | |
| Half Baths | 1 | | Depreciation % | | 27 |
| Extra Fixtures | 2 | | Functional Obsol | | |
| Total Rooms | 7 | | External Obsol | | |
| Bath Style | 03 | Modern | Trend Factor | | 1.000 |
| Kitchen Style | 03 | Modern | Condition | | |
| Extra Kitchens | 0 | | Condition % | | |
| Fireplaces | 1 | | Percent Good | | 73 |
| Extra Openings | 0 | | Cns Sect Rcnld | | 422,200 |
| Gas Fireplaces | 0 | | Dep % Ovr | | |
| Sq Ft Fin Bsmt | 558 | | Dep Ovr Comment | | |
| FBM Quality | 03 | Average | Misc Imp Ovr | | |
| Foundation | 05 | Conc Block | Misc Imp Ovr Comment | | |
| Bsmt Garage | 0 | | Cost to Cure Ovr | | |
| Bsmt Area | 776 | | Cost to Cure Ovr Comment | | |

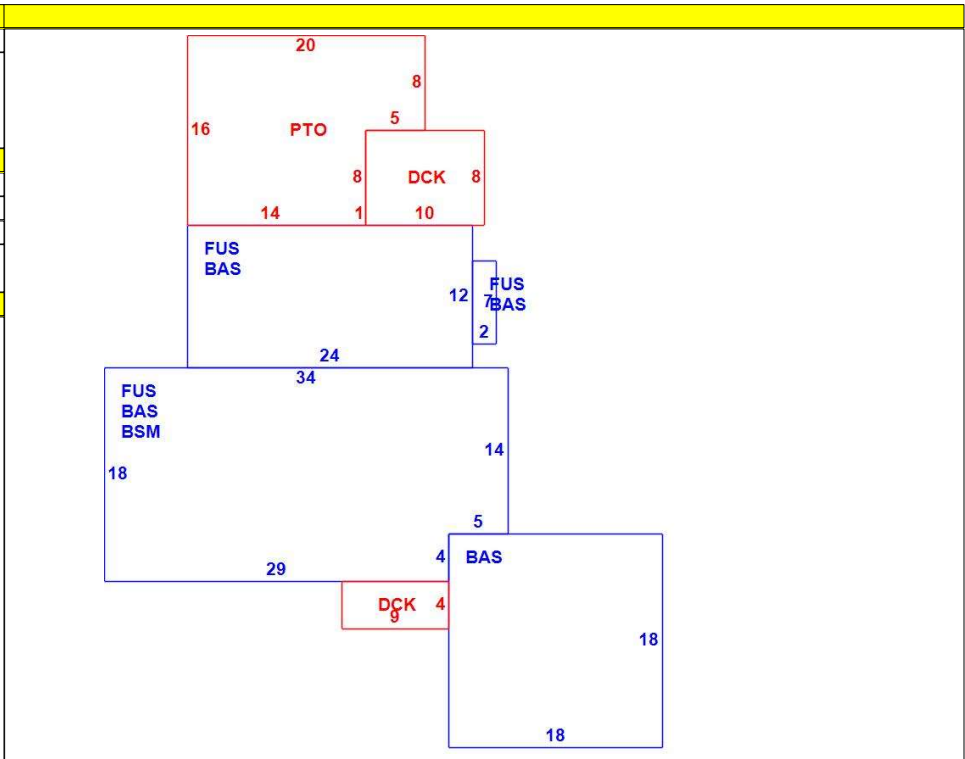

OB - OUTBUILDING & YARD ITEMS(L) / XF - BUILDING EXTRA FEATURES(B)

| Code | Description | L/B | Units | Unit Price | Yr Blt | Cond. Cd | % Gd | Grade | Grade Adj. | Appr. Value |
|------|-------------|-----|-------|------------|--------|----------|------|-------|------------|-------------|
| WDK | Deck | L | 116 | 21.00 | 2009 | G | 85 | C | 1.00 | 2,100 |

BUILDING SUB-AREA SUMMARY SECTION

| Code | Description | Living Area | Floor Area | Eff Area | Unit Cost | Undeprec Value |
|----------------------------|----------------------|-------------|------------|----------|-----------|----------------|
| BAS | First Floor | 1,218 | 1,218 | 1,218 | 236.38 | 287,910 |
| BSM | Basement | 0 | 592 | 118 | 47.12 | 27,893 |
| DCK | Deck | 0 | 116 | 12 | 24.45 | 2,837 |
| FUS | Finished Upper Story | 894 | 894 | 894 | 236.38 | 211,323 |
| PTO | Patio | 0 | 280 | 14 | 11.82 | 3,309 |
| Ttl Gross Liv / Lease Area | | 2,112 | 3,100 | 2,256 | | 533,272 |

