

CURRENT OWNER		TOPO		UTILITIES		STRT / ROAD		LOCATION		CURRENT ASSESSMENT				905 DUXBURY, MA VISION								
KOEDEL DOROTHY L 44 SUNSET PL BERGENFIELD NJ 07621		0	Water	0	Subdivision	0	Average	Description		Code	Appraised	Assessed										
		0	No Sewer	0	Paved	0	Average	RESIDENTL		1010	79,700	79,700										
		0	Light	0	Light	0	Average	RES LAND		1010	447,700	447,700										
SUPPLEMENTAL DATA										Total		527,400	527,400									
Alt Prcl ID		Scnd Home		Tax Class		Tot Fin Area		Total Acres		Chapter Lan		GIS ID		Cyclical Exemption W District Res Exem		Assoc Pid#						
		500359		T		580		.172				F_871253_2830956		7								
RECORD OF OWNERSHIP				BK-VOL/PAGE		SALE DATE		Q/U V/I		SALE PRICE		VC		PREVIOUS ASSESSMENTS (HISTORY)								
KOEDEL DOROTHY L				7027 0120		08-14-1986		Q I		55,000		00		Year	Code	Assessed	Year	Code	Assessed			
														2023	1010	60,100	2022	1010	52,300			
															1010	335,700		1010	294,500			
														Total		395,800	Total		346,800	Total		291,200
EXEMPTIONS				OTHER ASSESSMENTS				This signature acknowledges a visit by a Data Collector or Assessor														
Year	Code	Description		Amount		Code	Description	Number	Amount	Comm Int												
Total				0.00																		
ASSESSING NEIGHBORHOOD										APPRAISED VALUE SUMMARY												
Nbhd		Nbhd Name		B		Tracing		Batch		Appraised Bldg. Value (Card)					79,700							
0040										Appraised Xf (B) Value (Bldg)					0							
										Appraised Ob (B) Value (Bldg)					0							
										Appraised Land Value (Bldg)					447,700							
										Special Land Value					0							
										Total Appraised Parcel Value					527,400							
										Valuation Method					C							
										Total Appraised Parcel Value					527,400							
BUILDING PERMIT RECORD										VISIT / CHANGE HISTORY												
Permit Id	Issue Date	Type	Description	Amount	Insp Date	% Comp	Date Comp	Comments		Date	Id	Type	Is	Cd	Purpose/Result							
										08-09-2023	SJD	6		20	Field Review							
										02-12-2018	JLF	0	1	00	Measure & Listed							
										08-01-2013	SJD	3	1	30	Quality Control							
										04-12-2013	VGS			20	Field Review							
										10-09-1999	REC		6	00	Measure & Listed							
LAND LINE VALUATION SECTION																						
B	Use Code	Description	Zone	Land Type	Land Units	Unit Price	Size Adj	Site Index	Cond.	Nbhd.	Nbhd. Adj	Notes		Location Adjustment	Adj Unit P	Land Value						
1	1010	Single Family	RC	Primary	7,500 SF	32.80	1.00000	5	1.00	0040	1.820			1.0000	59.69	447,700						
Total Card Land Units					0.17	AC	Parcel Total Land Area					0.17	Total Land Value			447,700						

CONSTRUCTION DETAIL			CONSTRUCTION DETAIL (CONTINUED)		
Element	Cd	Description	Element	Cd	Description
Style	01	Ranch	Bsmt Area	100	
Model	01	Residential	Bsmt Type	02	
Grade	03	Average	Unfin Area	0.00	Crawl
Stories	1				
Occupancy	1		CONDO DATA		
Exterior Wall 1	14	Wood Shingle	Parcel Id		C
Exterior Wall 2					B
Roof Structure	03	Gable	Adjust Type	Code	Description
Roof Cover	03	Asphalt	Condo Flr		
Interior Wall 1	07	Pine/Wood	Condo Unit		
Interior Wall 2			COST / MARKET VALUATION		
Interior Floor 1	14	Carpet	Net Other Adj		113,943
Interior Floor 2	06	Linoleum	Replace Cost		5,000
Heat Fuel	07	Propane	Year Built		118,942
Heat Type	04	Forced Air-Duc	Effective Year Built		1930
AC Type	01	None	Depreciation Code		1988
Bedrooms	2		Remodel Rating		A
Full Baths	1		Year Remodeled		
Half Baths	0		Depreciation %		33
Extra Fixtures	0		Functional Obsol		
Total Rooms	3		External Obsol		
Bath Style	01	Old Style	Trend Factor		1.000
Kitchen Style	01	Old Style	Condition		
Extra Kitchens	0		Condition %		
Fireplaces	0		Percent Good		67
Extra Openings	0		Cns Sect Rcnld		79,700
Gas Fireplaces	0		Dep % Ovr		
Sq Ft Fin Bsmt	0		Dep Ovr Comment		
FBM Quality			Misc Imp Ovr		
Foundation	05	Conc Block	Misc Imp Ovr Comment		
Bsmt Garage	0		Cost to Cure Ovr		
Bsmt Area	100		Cost to Cure Ovr Comment		

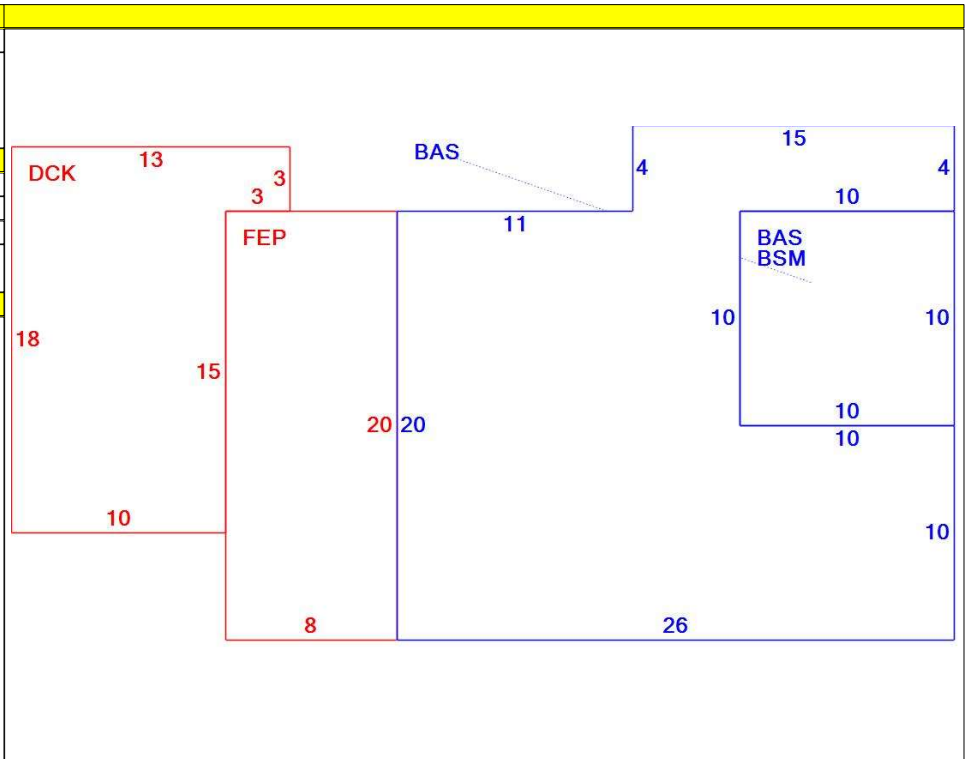

OB - OUTBUILDING & YARD ITEMS(L) / XF - BUILDING EXTRA FEATURES(B)										
Code	Description	L/B	Units	Unit Price	Yr Blt	Cond. Cd	% Gd	Grade	Grade Adj.	Appr. Value

BUILDING SUB-AREA SUMMARY SECTION						
Code	Description	Living Area	Floor Area	Eff Area	Unit Cost	Undeprec Value
BAS	First Floor	580	580	580	159.36	92,429
BSM	Basement	0	100	20	31.87	3,187
DCK	Deck	0	189	19	16.02	3,028
FEP	Finished Enclosed Porch	0	160	96	95.62	15,299
Ttl Gross Liv / Lease Area		580	1,029	715		113,943

