

| CURRENT OWNER | | TOPO | UTILITIES | STRT / ROAD | LOCATION | CURRENT ASSESSMENT | | | |
|-----------------------------|--|------|------------|---------------|-----------|--------------------|------|-----------|-----------|
| STEVENS SUZANNE C TT | | | 0 Water | 0 Subdivision | 0 Average | Description | Code | Appraised | Assessed |
| SUZANNE C STEVENS REVOCABLE | | | 0 No Sewer | 0 Paved | 0 Average | RESIDENTL | 1010 | 971,700 | 971,700 |
| 70 ONION HILL RD | | | | 0 Light | | RES LAND | 1010 | 1,017,500 | 1,017,500 |
| SUPPLEMENTAL DATA | | | | | | | | | |
| Alt Prcl ID | | | | Cyclical 5 | | | | | |
| Scnd Home | | | | Exemption | | | | | |
| Tax Class T | | | | W | | | | | |
| Tot Fin Area 3256 | | | | District | | | | | |
| Total Acres 2.418 | | | | Res Exem | | | | | |
| Chapter Lan | | | | | | | | | |
| GIS ID F_877795_2844979 | | | | Assoc Pid# | | | | | |
| | | | | | | Total | | 1,989,200 | 1,989,200 |

905
 DUXBURY, MA
VISION

| RECORD OF OWNERSHIP | | BK-VOL/PAGE | SALE DATE | Q/U | V/I | SALE PRICE | VC | PREVIOUS ASSESSMENTS (HISTORY) | | | | | | | | |
|----------------------------|--|-------------|------------|-----|-----|------------|----|--------------------------------|------|-----------|-------|------|-----------|-------|--|-----------|
| STEVENS SUZANNE C TT | | 43671 0160 | 10-01-2013 | U | I | 1,400,000 | 1 | Year | Code | Assessed | Year | Code | Assessed | | | |
| DUDDY BRIAN P & KATHLEEN M | | 35226 0168 | 10-26-2007 | U | I | 1,225,000 | 1 | 2023 | 1010 | 741,700 | 2022 | 1010 | 690,100 | | | |
| CORBETT JOHN W III | | 17746 0148 | 08-06-1999 | Q | I | 190,000 | 00 | | 1010 | 1,208,700 | | 1010 | 1,080,500 | | | |
| | | | | | | | | Total | | 1,950,400 | Total | | 1,770,600 | Total | | 1,487,700 |

| EXEMPTIONS | | | OTHER ASSESSMENTS | | | | | |
|------------|------|-------------|-------------------|------|-------------|--------|--------|----------|
| Year | Code | Description | Amount | Code | Description | Number | Amount | Comm Int |
| | | Total | 0.00 | | | | | |

This signature acknowledges a visit by a Data Collector or Assessor

| ASSESSING NEIGHBORHOOD | | | | |
|------------------------|-----------|---|---------|-------|
| Nbhd | Nbhd Name | B | Tracing | Batch |
| 0080 | | | | |

| BUILDING PERMIT RECORD | | | | | | | | VISIT / CHANGE HISTORY | | | | | | |
|------------------------|------------|------|---------------|---------|------------|--------|-----------|------------------------|------------|-----|------|----|----|--------------------|
| Permit Id | Issue Date | Type | Description | Amount | Insp Date | % Comp | Date Comp | Comments | Date | Id | Type | Is | Cd | Purpose/Result |
| 20 | 01-09-2008 | AD | Addition | 37,000 | 07-15-2008 | 100 | | 18X22 1STY/SHED/DORM | 02-08-2022 | SJT | 0 | | 00 | Measure & Listed |
| 398 | 12-18-2007 | AD | Addition | 26,000 | 07-15-2008 | 100 | | 15'DORMER/RM 24'24' | 10-19-2020 | SJT | 10 | | 20 | Field Review |
| 19990331 | 07-22-1999 | NC | New Construct | 164,000 | 04-26-2001 | 100 | | 2STY WGAR& DORM | 04-22-2014 | SJD | 9 | | 01 | Measure - No Entry |
| | | | | | | | | | 04-12-2013 | VGS | | | 20 | Field Review |
| | | | | | | | | | 07-16-2008 | KP | | 1 | 00 | Measure & Listed |

| LAND LINE VALUATION SECTION | | | | | | | | | | | | | | | | | |
|-----------------------------|----------|---------------|------|-----------|------------|------------|------------------------|------------|-------|-------|-----------|-------|---------------------|------------|------------|-----------|-----------|
| B | Use Code | Description | Zone | Land Type | Land Units | Unit Price | Size Adj | Site Index | Cond. | Nbhd. | Nbhd. Adj | Notes | Location Adjustment | Adj Unit P | Land Value | | |
| 1 | 1010 | Single Family | RC | Primary | 24,394 SF | 13.15 | 1.00000 | 5 | 1.00 | 0080 | 1.503 | | V210 | 2.1000 | 41.50 | 1,012,400 | |
| 1 | 1010 | Single Family | RC | Undevelop | 1.860 AC | 2,000.00 | 0.90752 | 0 | 1.00 | 0080 | 1.503 | | | 1.0000 | 0.06 | 5,100 | |
| Total Card Land Units | | | | | 2.42 | AC | Parcel Total Land Area | | | | | 2.42 | Total Land Value | | | | 1,017,500 |

| CONSTRUCTION DETAIL | | | CONSTRUCTION DETAIL (CONTINUED) | | |
|---------------------|------|----------------|---------------------------------|------|-------------|
| Element | Cd | Description | Element | Cd | Description |
| Style | 03 | Colonial | Bsmt Area | 1628 | |
| Model | 01 | Residential | Bsmt Type | 04 | |
| Grade | 09 | Custom | Unfin Area | 0.00 | Full |
| Stories | 2 | | | | |
| Occupancy | 1 | | | | |
| Exterior Wall 1 | 14 | Wood Shingle | CONDO DATA | | |
| Exterior Wall 2 | | | Parcel Id | | C |
| Roof Structure | 04 | Hip | | | Owne |
| Roof Cover | 03 | Asphalt | | | B |
| Interior Wall 1 | 05 | Drywall | | | S |
| Interior Wall 2 | | | Adjust Type | Code | Description |
| Interior Floor 1 | 12 | Hardwood | Condo Flr | | Factor% |
| Interior Floor 2 | | | Condo Unit | | |
| Heat Fuel | 03 | Gas | COST / MARKET VALUATION | | |
| Heat Type | 04 | Forced Air-Duc | Net Other Adj | | 1,015,130 |
| AC Type | 03 | Central | Replace Cost | | 64,505 |
| Bedrooms | 3 | | Year Built | | 2000 |
| Full Baths | 2 | | Effective Year Built | | 2011 |
| Half Baths | 1 | | Depreciation Code | | VG |
| Extra Fixtures | 2 | | Remodel Rating | | |
| Total Rooms | 11 | | Year Remodeled | | |
| Bath Style | 02 | Average | Depreciation % | | 10 |
| Kitchen Style | 03 | Modern | Functional Obsol | | |
| Extra Kitchens | 0 | | External Obsol | | |
| Fireplaces | 1 | | Trend Factor | | 1.000 |
| Extra Openings | 0 | | Condition | | |
| Gas Fireplaces | 1 | | Condition % | | |
| Sq Ft Fin Bsmt | 594 | | Percent Good | | 90 |
| FBM Quality | 03 | Average | Cns Sect Rcnld | | 971,700 |
| Foundation | 06 | Poured Conc | Dep % Ovr | | |
| Bsmt Garage | 0 | | Dep Ovr Comment | | |
| Bsmt Area | 1628 | | Misc Imp Ovr | | |
| | | | Misc Imp Ovr Comment | | |
| | | | Cost to Cure Ovr | | |
| | | | Cost to Cure Ovr Comment | | |

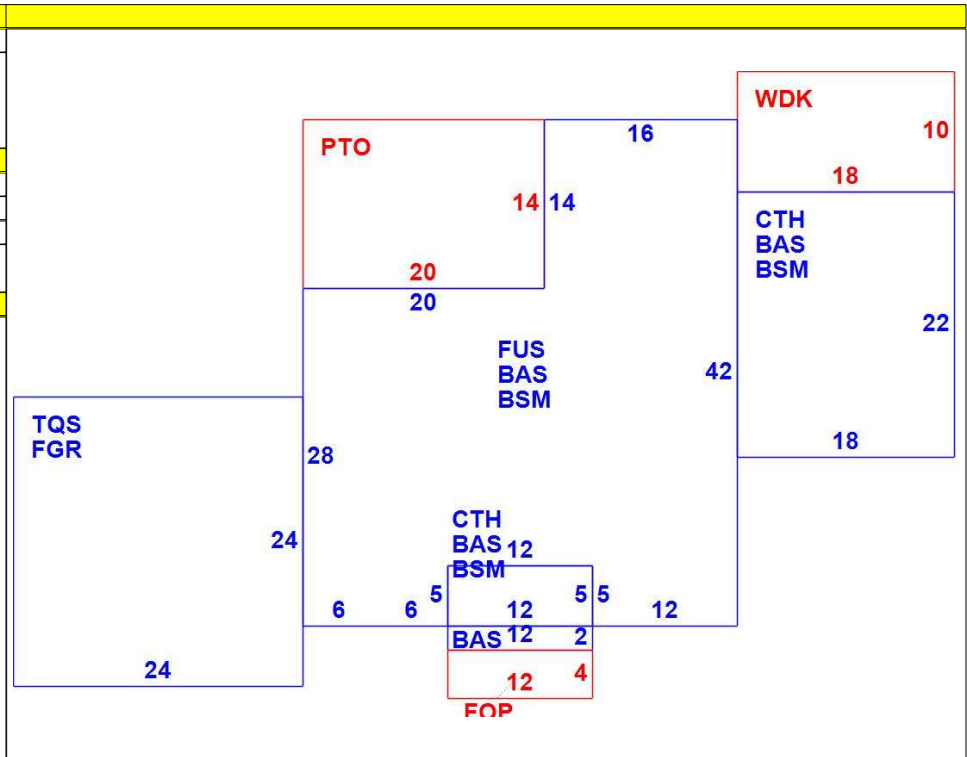

| OB - OUTBUILDING & YARD ITEMS(L) / XF - BUILDING EXTRA FEATURES(B) | | | | | | | | | | |
|--|-------------|-----|-------|------------|--------|----------|------|-------|------------|-------------|
| Code | Description | L/B | Units | Unit Price | Yr Blt | Cond. Cd | % Gd | Grade | Grade Adj. | Appr. Value |
| | | | | | | | | | | |

| BUILDING SUB-AREA SUMMARY SECTION | | | | | | | |
|-----------------------------------|----------------------|-------------|------------|----------|-----------|----------------|--|
| Code | Description | Living Area | Floor Area | Eff Area | Unit Cost | Undeprec Value | |
| BAS | First Floor | 1,652 | 1,652 | 1,652 | 260.49 | 430,329 | |
| BSM | Basement | 0 | 1,628 | 326 | 52.16 | 84,920 | |
| CTH | Cathedral Ceiling | 0 | 456 | 46 | 26.28 | 11,983 | |
| FGR | Garage | 0 | 576 | 230 | 104.02 | 59,913 | |
| FOP | Open Porch | 0 | 48 | 7 | 37.99 | 1,823 | |
| FUS | Finished Upper Story | 1,172 | 1,172 | 1,172 | 260.49 | 305,294 | |
| PTO | Patio | 0 | 280 | 14 | 13.02 | 3,647 | |
| TQS | Three Quarter Story | 432 | 576 | 432 | 195.37 | 112,532 | |
| WDK | Deck | 0 | 180 | 18 | 26.05 | 4,689 | |
| Ttl Gross Liv / Lease Area | | 3,256 | 6,568 | 3,897 | | 1,015,130 | |

