

CONSTRUCTION DETAIL			CONSTRUCTION DETAIL (CONTINUED)		
Element	Cd	Description	Element	Cd	Description
Style	00	Gambrel	Bsmt Area	1528	
Model	01	Residential	Bsmt Type	04	
Grade	06	Good	Unfin Area	0.00	Full
Stories	2				
Occupancy	1				
Exterior Wall 1	14	Wood Shingle			
Exterior Wall 2	25	Vinyl Siding			
Roof Structure	07	Gambrel			
Roof Cover	03	Asphalt			
Interior Wall 1	05	Drywall			
Interior Wall 2					
Interior Floor 1	12	Hardwood			
Interior Floor 2	14	Carpet			
Heat Fuel	02	Oil			
Heat Type	05	Hot Water			
AC Type	01	None			
Bedrooms	4				
Full Baths	2				
Half Baths	1				
Extra Fixtures					
Total Rooms	10				
Bath Style	02	Average			
Kitchen Style	02	Average			
Extra Kitchens	0				
Fireplaces	2				
Extra Openings	1				
Gas Fireplaces	0				
Sq Ft Fin Bsmt					
FBM Quality					
Foundation	06	Poured Conc			
Bsmt Garage	0				
Bsmt Area	1528				

CONDO DATA			
Parcel Id		C	Owne
			B S
Adjust Type	Code	Description	Factor%
Condo Flr			
Condo Unit			

COST / MARKET VALUATION	
Net Other Adj	679,061
Replace Cost	28,130
Year Built	1981
Effective Year Built	1994
Depreciation Code	A
Remodel Rating	
Year Remodeled	
Depreciation %	27
Functional Obsol	
External Obsol	
Trend Factor	1.000
Condition	
Condition %	
Percent Good	73
Cns Sect Rcnd	516,200
Dep % Ovr	
Dep Ovr Comment	
Misc Imp Ovr	
Misc Imp Ovr Comment	
Cost to Cure Ovr	
Cost to Cure Ovr Comment	

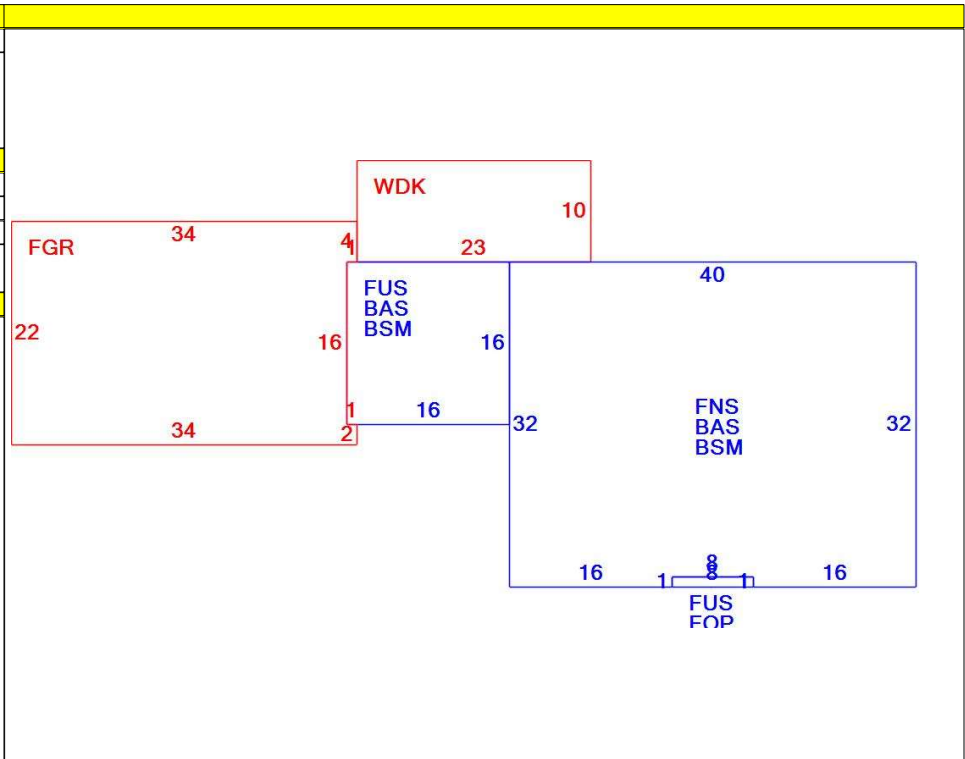

OB - OUTBUILDING & YARD ITEMS(L) / XF - BUILDING EXTRA FEATURES(B)

Code	Description	L/B	Units	Unit Price	Yr Blt	Cond. Cd	% Gd	Grade	Grade Adj.	Appr. Value
SPL1	Ing Pool - Ave	L	756	64.00	1985	A	70	C	1.00	33,900
SHD1	Shed	L	64	21.00	1989	A	70	C	1.00	900
SHD1	Shed	L	80	21.00	2016	G	85	C	1.00	1,400

BUILDING SUB-AREA SUMMARY SECTION

Code	Description	Living Area	Floor Area	Eff Area	Unit Cost	Undeprec Value
BAS	First Floor	1,528	1,528	1,528	190.75	291,462
BSM	Basement	0	1,528	306	38.20	58,369
FGR	Garage	0	732	293	76.35	55,889
FNS	Finished 90% Story	1,145	1,272	1,145	171.70	218,406
FOP	Open Porch	0	8	1	23.84	191
FUS	Finished Upper Story	264	264	264	190.75	50,357
WDK	Deck	0	230	23	19.07	4,387
Ttl Gross Liv / Lease Area		2,937	5,562	3,560		679,061

