

CONSTRUCTION DETAIL			CONSTRUCTION DETAIL (CONTINUED)		
Element	Cd	Description	Element	Cd	Description
Style	04	Cape Cod	Bsmt Area	3026	
Model	01	Residential	Bsmt Type	03	
Grade	15	Deluxe	Unfin Area	0.00	Partial
Stories	2				
Occupancy	1		CONDO DATA		
Exterior Wall 1	14	Wood Shingle	Parcel Id		C
Exterior Wall 2					B
Roof Structure	03	Gable	Adjust Type	Code	Description
Roof Cover	10	Wood Shingle	Condo Flr		
Interior Wall 1	05	Drywall	Condo Unit		
Interior Wall 2			COST / MARKET VALUATION		
Interior Floor 1	09	Pine/Soft Wood			
Interior Floor 2			Net Other Adj		2,646,678
Heat Fuel	03	Gas	Replace Cost		2,913,178
Heat Type	05	Hot Water	Year Built		2010
AC Type	03	Central	Effective Year Built		2013
Bedrooms	4		Depreciation Code		VG
Full Baths	5		Remodel Rating		
Half Baths	2		Year Remodeled		
Extra Fixtures	4		Depreciation %		8
Total Rooms	11		Functional Obsol		
Bath Style	03	Modern	External Obsol		
Kitchen Style	03	Modern	Trend Factor		1.000
Extra Kitchens	0		Condition		
Fireplaces	1		Condition %		
Extra Openings	3		Percent Good		92
Gas Fireplaces	0		Cns Sect Rcnd		2,680,100
Sq Ft Fin Bsmt	1900		Dep % Ovr		
FBM Quality	05	Living Area	Dep Ovr Comment		
Foundation	06	Poured Conc	Misc Imp Ovr		
Bsmt Garage	2		Misc Imp Ovr Comment		
Bsmt Area	3026		Cost to Cure Ovr		
			Cost to Cure Ovr Comment		

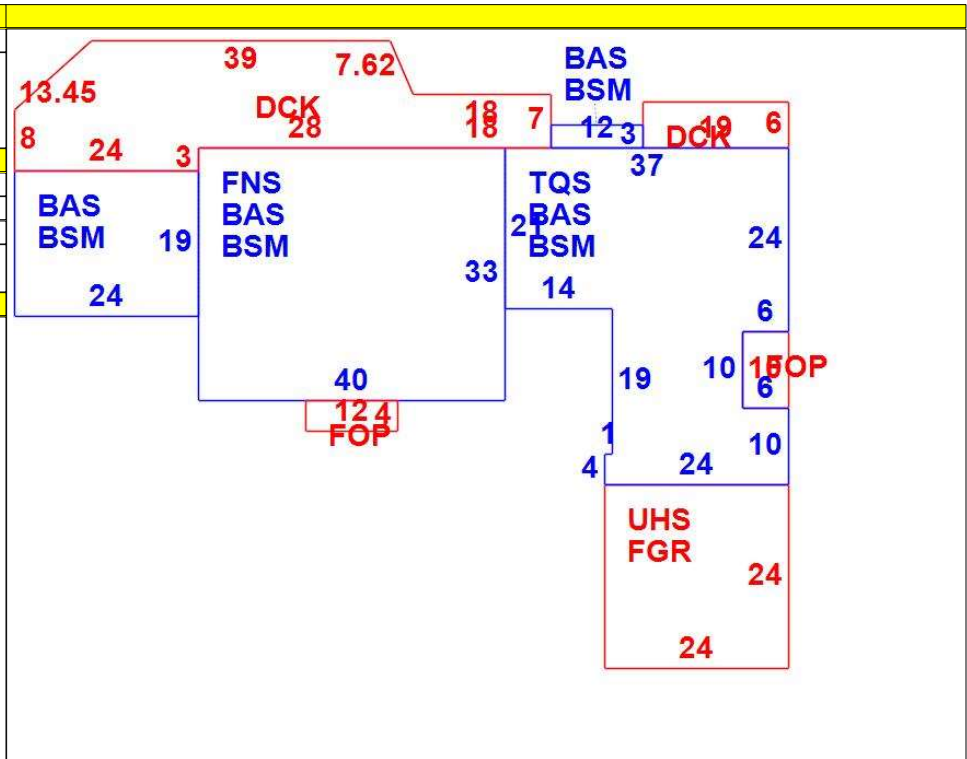

OB - OUTBUILDING & YARD ITEMS(L) / XF - BUILDING EXTRA FEATURES(B)										
Code	Description	L/B	Units	Unit Price	Yr Blt	Cond. Cd	% Gd	Grade	Grade Adj.	Appr. Value
FGR1	Garage - 1 Sto	L	252	52.00	2000	A	70	C	1.00	9,200
SHD1	Shed	L	243	21.00	2000	A	70	C	1.00	3,600
GNR	GENERATOR	L	1	12400.00	2011	A	70	C	1.00	8,700

BUILDING SUB-AREA SUMMARY SECTION						
Code	Description	Living Area	Floor Area	Eff Area	Unit Cost	Undeprec Value
BAS	First Floor	3,062	3,062	3,062	420.84	1,288,620
BSM	Basement	0	3,062	612	84.11	257,556
DCK	Deck	0	985	99	42.30	41,663
FGR	Garage	0	576	230	168.04	96,794
FNS	Finished 90% Story	1,188	1,320	1,188	378.76	499,961
FOP	Open Porch	0	108	16	62.35	6,733
TQS	Three Quarter Story	938	1,250	938	315.80	394,750
UHS	Unfinished Half Story	0	576	144	105.21	60,601
Ttl Gross Liv / Lease Area		5,188	10,939	6,289		2,646,678

