

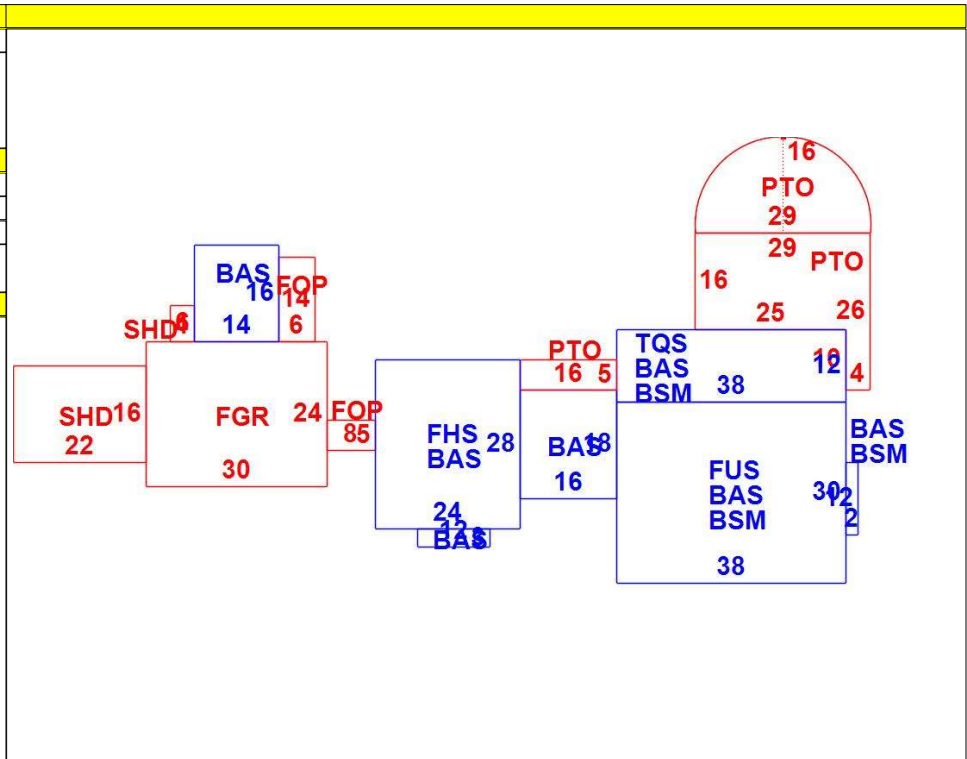

CONSTRUCTION DETAIL			CONSTRUCTION DETAIL (CONTINUED)		
Element	Cd	Description	Element	Cd	Description
Style	03	Colonial	Bsmt Area	1622	
Model	01	Residential	Bsmt Type	04	
Grade	11	Prime	Unfin Area	0.00	Full
Stories	2		<b>CONDO DATA</b>		
Occupancy	1		Parcel Id		C
Exterior Wall 1	14	Wood Shingle			B
Exterior Wall 2					S
Roof Structure	03	Gable	Adjust Type	Code	Description
Roof Cover	10	Wood Shingle	Condo Flr		
Interior Wall 1	05	Drywall	Condo Unit		
Interior Wall 2			<b>COST / MARKET VALUATION</b>		
Interior Floor 1	12	Hardwood	Net Other Adj		1,577,410
Interior Floor 2			Replace Cost		49,950
Heat Fuel	03	Gas	Year Built		1,627,360
Heat Type	05	Hot Water	Effective Year Built		1952
AC Type	03	Central	Depreciation Code		2005
Bedrooms	4		Remodel Rating		E
Full Baths	4		Year Remodeled		
Half Baths	0		Depreciation %		16
Extra Fixtures	4		Functional Obsol		
Total Rooms	11		External Obsol		
Bath Style	03	Modern	Trend Factor		1.000
Kitchen Style	03	Modern	Condition		
Extra Kitchens	0		Condition %		
Fireplaces	1		Percent Good		84
Extra Openings	0		Cns Sect Rcnd		1,367,000
Gas Fireplaces	0		Dep % Ovr		
Sq Ft Fin Bsmt	0		Dep Ovr Comment		
FBM Quality			Misc Imp Ovr		
Foundation	06	Poured Conc	Misc Imp Ovr Comment		
Bsmt Garage	0		Cost to Cure Ovr		
Bsmt Area	1622		Cost to Cure Ovr Comment		



**OB - OUTBUILDING & YARD ITEMS(L) / XF - BUILDING EXTRA FEATURES(B)**

Code	Description	L/B	Units	Unit Price	Yr Blt	Cond. Cd	% Gd	Grade	Grade Adj.	Appr. Value
SHD1	Shed	L	216	21.00	1995	A	70	C	1.00	3,200
GNR	GENERATOR	L	1	12400.00	2010	A	70	C	1.00	8,700

**BUILDING SUB-AREA SUMMARY SECTION**

Code	Description	Living Area	Floor Area	Eff Area	Unit Cost	Undeprec Value
BAS	First Floor	2,840	2,840	2,840	288.43	819,134
BSM	Basement	0	1,620	324	57.69	93,451
FGR	Garage	0	720	288	115.37	83,067
FHS	Finished Half Story	336	672	336	144.21	96,912
FOP	Open Porch	0	124	19	44.19	5,480
FUS	Finished Upper Story	1,140	1,140	1,140	288.43	328,807
PTO	Patio	0	959	48	14.44	13,845
SHD	Attached Shed	0	376	132	101.26	38,072
TQS	Three Quarter Story	342	456	342	216.32	98,642
Ttl Gross Liv / Lease Area		4,658	8,907	5,469		1,577,410

