

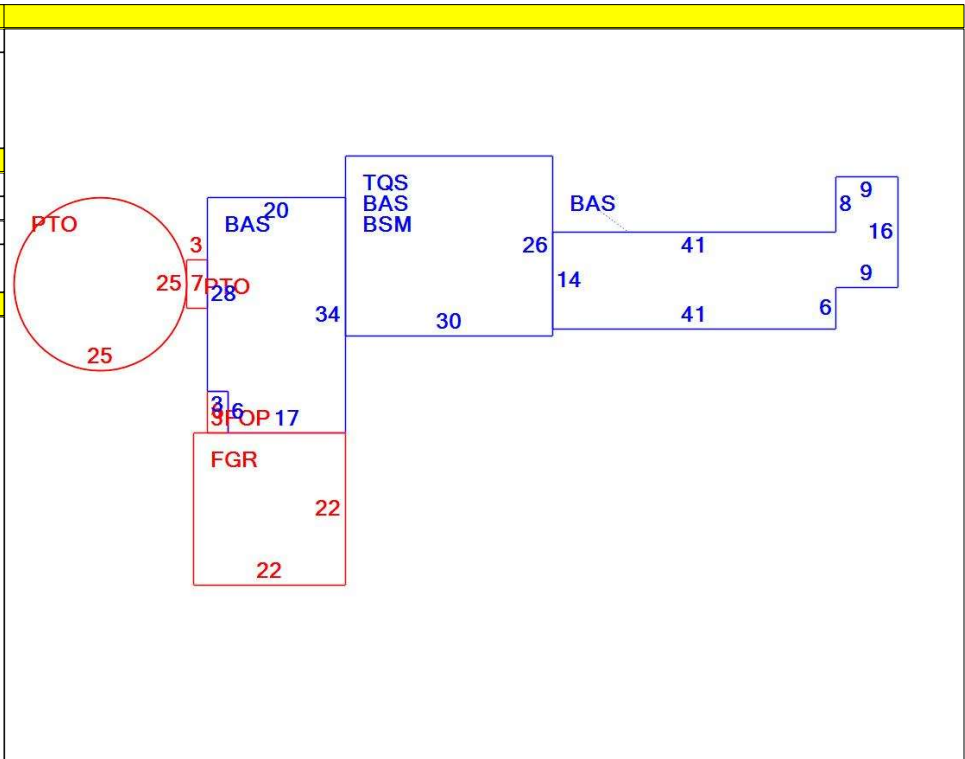

**CONSTRUCTION DETAIL**      **CONSTRUCTION DETAIL (CONTINUED)**

Element	Cd	Description	Element	Cd	Description
Style	04	Cape Cod	Bsmt Area	780	
Model	01	Residential	Bsmt Type	00	
Grade	06	Good	Unfin Area	0.00	N/A
Stories	1.75				
Occupancy	1		<b>CONDO DATA</b>		
Exterior Wall 1	14	Wood Shingle	Parcel Id		C
Exterior Wall 2					B
Roof Structure	03	Gable	Adjust Type	Code	Description
Roof Cover	10	Wood Shingle	Condo Flr		
Interior Wall 1	05	Drywall	Condo Unit		
Interior Wall 2			<b>COST / MARKET VALUATION</b>		
Interior Floor 1	09	Pine/Soft Wood	Net Other Adj		669,641
Interior Floor 2			Replace Cost		29,290
Heat Fuel	03	Gas	Year Built		698,930
Heat Type	04	Forced Air-Duc	Effective Year Built		1950
AC Type	01	None	Depreciation Code		1994
Bedrooms	4		Remodel Rating		G
Full Baths	3		Year Remodeled		
Half Baths	1		Depreciation %		27
Extra Fixtures	1		Functional Obsol		
Total Rooms	7		External Obsol		
Bath Style	02	Average	Trend Factor		1.000
Kitchen Style	02	Average	Condition		
Extra Kitchens	0		Condition %		
Fireplaces	1		Percent Good		73
Extra Openings	1		Cns Sect Rcnd		510,200
Gas Fireplaces	0		Dep % Ovr		
Sq Ft Fin Bsmt	0		Dep Ovr Comment		
FBM Quality			Misc Imp Ovr		
Foundation	06	Poured Conc	Misc Imp Ovr Comment		
Bsmt Garage	0		Cost to Cure Ovr		
Bsmt Area	780		Cost to Cure Ovr Comment		



**OB - OUTBUILDING & YARD ITEMS(L) / XF - BUILDING EXTRA FEATURES(B)**

Code	Description	L/B	Units	Unit Price	Yr Blt	Cond. Cd	% Gd	Grade	Grade Adj.	Appr. Value
BRN1	Barn - 1 Story	L	432	39.00	1999	A	70	C	1.00	11,800
GNR	GENERATOR	L	1	12400.00	2013	A	70	C	1.00	8,700

**BUILDING SUB-AREA SUMMARY SECTION**

Code	Description	Living Area	Floor Area	Eff Area	Unit Cost	Undeprec Value
BAS	First Floor	2,160	2,160	2,160	214.35	463,004
BSM	Basement	0	780	156	42.87	33,439
FGR	Garage	0	484	194	85.92	41,585
FOP	Open Porch	0	18	3	35.73	643
PTO	Patio	0	512	26	10.89	5,573
TQS	Three Quarter Story	585	780	585	160.77	125,397
Ttl Gross Liv / Lease Area		2,745	4,734	3,124		669,641



16 WESTON RD

