

| CURRENT OWNER      |  | TOPO   | UTILITIES  | STRT / ROAD | LOCATION  | CURRENT ASSESSMENT |         |           |           |
|--------------------|--|--|------------|-------------|---|--------------------|---------|-----------|-----------|
| SCHOMP ALBERT L IV |  |  | 0 Water    | 0 Arterial  | 0 Average   | Description        | Code    | Appraised | Assessed  |
| SCHOMP AMY C       |  |  | 0 No Sewer | 0 Paved     | 0 Average   | RESIDNTL           | 1010    | 716,500   | 716,500   |
| 875 TREMONT ST     |  | <b>SUPPLEMENTAL DATA</b>   |            |             | RES LAND  | 1010               | 487,700 | 487,700   |           |
| DUXBURY MA 02332   |  | Alt Prcl ID<br>Scnd Home<br>Tax Class T<br>Tot Fin Area 3520<br>Total Acres .948<br>Chapter Lan<br>GIS ID F_876470_2839007 |            |             | Cyclical 5<br>Exemption W<br>District<br>Res Exem<br>Assoc Pid# | RESIDNTL           | 1010    | 20,100    | 20,100    |
|                    |  |  |            |             |   | Total              |         | 1,224,300 | 1,224,300 |

**VISION**

| RECORD OF OWNERSHIP |  | BK-VOL/PAGE | SALE DATE  | Q/U | V/I | SALE PRICE | VC | PREVIOUS ASSESSMENTS (HISTORY) |      |          |      |         |          |
|---------------------|--|-------------|------------|-----|-----|------------|----|--------------------------------|------|----------|------|---------|----------|
| SCHOMP ALBERT L IV  |  | 16008 0203  | 03-23-1998 | Q   | I   | 348,250    | 00 | Year                           | Code | Assessed | Year | Code    | Assessed |
|                     |  |             |            |     |     |            |    | 2023                           | 1010 | 578,200  | 2022 | 1010    | 542,500  |
|                     |  |             |            |     |     |            |    |                                | 1010 | 476,400  |      | 1010    | 402,000  |
|                     |  |             |            |     |     |            |    |                                | 1010 | 15,400   |      | 1010    | 15,400   |
|                     |  |             |            |     |     | Total      |    | 1,070,000                      |      | Total    |      | 959,900 |          |
|                     |  |             |            |     |     |            |    | Total                          |      | Total    |      | 861,400 |          |

| EXEMPTIONS |      |             | OTHER ASSESSMENTS |      |             |        |        |          |
|------------|------|-------------|-------------------|------|-------------|--------|--------|----------|
| Year       | Code | Description | Amount            | Code | Description | Number | Amount | Comm Int |
|            |      | Total       | 0.00              |      |             |        |        |          |

This signature acknowledges a visit by a Data Collector or Assessor

| ASSESSING NEIGHBORHOOD |           |   |         |       |
|------------------------|-----------|---|---------|-------|
| Nbhd                   | Nbhd Name | B | Tracing | Batch |
| 0070                   |           |   |         |       |

| NOTES |  |  |  |
|-------|--|--|--|
|       |  |  |  |

| APPRAISED VALUE SUMMARY       |           |
|-------------------------------|-----------|
| Appraised Bldg. Value (Card)  | 716,500   |
| Appraised Xf (B) Value (Bldg) | 0         |
| Appraised Ob (B) Value (Bldg) | 20,100    |
| Appraised Land Value (Bldg)   | 487,700   |
| Special Land Value            | 0         |
| Total Appraised Parcel Value  | 1,224,300 |
| Valuation Method              | C         |
| Total Appraised Parcel Value  | 1,224,300 |

| BUILDING PERMIT RECORD |            |      |               |         |            |        |           | VISIT / CHANGE HISTORY |            |     |      |    |    |                  |
|------------------------|------------|------|---------------|---------|------------|--------|-----------|------------------------|------------|-----|------|----|----|------------------|
| Permit Id              | Issue Date | Type | Description   | Amount  | Insp Date  | % Comp | Date Comp | Comments               | Date       | Id  | Type | Is | Cd | Purpose/Result   |
| 227                    | 06-27-2006 | MS   | Miscellaneous | 18,700  |            | 100    |           | 2 WINDOWS,14X16 DECK   | 10-22-2020 | SJT | 10   |    | 20 | Field Review     |
| 183                    | 05-22-2006 | MS   | Miscellaneous | 3,000   |            | 100    |           | INSTALL BEAM           | 04-12-2013 | VGS |      |    | 20 | Field Review     |
| 19990577               | 12-22-1999 | NC   | New Construct | 100,000 | 01-01-2002 | 100    |           | DM AND NC 1STY ADD     | 06-30-2006 | KP  |      | 1  | 00 | Measure & Listed |
| 14648                  | 08-29-1997 | NC   | New Construct | 17,000  | 08-10-1998 | 100    |           | 22X24 GAR, 4X8 ENTRY   |            |     |      |    |    |                  |
| 14131                  | 07-25-1996 | RM   | Remodel       | 2,000   | 09-11-1997 | 100    |           | 9.5 OPENING/KIT CABS   |            |     |      |    |    |                  |
| 12388                  | 06-19-1992 | AD   | Addition      | 32,000  | 01-01-1994 | 100    |           | FMLY/PORCH/DECK/BATH   |            |     |      |    |    |                  |

| LAND LINE VALUATION SECTION |          |               |      |           |            |                        |          |            |       |       |           |                  |                     |            |            |         |
|-----------------------------|----------|---------------|------|-----------|------------|------------------------|----------|------------|-------|-------|-----------|------------------|---------------------|------------|------------|---------|
| B                           | Use Code | Description   | Zone | Land Type | Land Units | Unit Price             | Size Adj | Site Index | Cond. | Nbhd. | Nbhd. Adj | Notes            | Location Adjustment | Adj Unit P | Land Value |         |
| 1                           | 1010     | Single Family | RC   | Primary   | 40,000 SF  | 8.75                   | 1.00000  | 5          | 1.00  | 0070  | 1.389     |                  |                     | 1.0000     | 12.16      | 486,200 |
| 1                           | 1010     | Single Family | RC   | Residual  | 0.030 AC   | 35,000.00              | 1.00000  | 5          | 1.00  | 0070  | 1.389     |                  |                     | 1.0000     | 1.15       | 1,500   |
| Total Card Land Units       |          |               |      |           | 0.95 AC    | Parcel Total Land Area |          |            |       |       | 0.95      | Total Land Value |                     |            | 487,700    |         |

| CONSTRUCTION DETAIL |      |               | CONSTRUCTION DETAIL (CONTINUED) |      |             |
|---------------------|------|---------------|---------------------------------|------|-------------|
| Element             | Cd   | Description   | Element                         | Cd   | Description |
| Style               | 00   | Gambrel       | Bsmt Area                       | 1944 |             |
| Model               | 01   | Residential   | Bsmt Type                       | 04   |             |
| Grade               | 07   | Very Good     | Unfin Area                      | 0.00 | Full        |
| Stories             | 2    |               |                                 |      |             |
| Occupancy           | 1    |               |                                 |      |             |
| Exterior Wall 1     | 14   | Wood Shingle  |                                 |      |             |
| Exterior Wall 2     |      |               |                                 |      |             |
| Roof Structure      | 07   | Gambrel       |                                 |      |             |
| Roof Cover          | 03   | Asphalt       |                                 |      |             |
| Interior Wall 1     | 05   | Drywall       |                                 |      |             |
| Interior Wall 2     |      |               |                                 |      |             |
| Interior Floor 1    | 12   | Hardwood      |                                 |      |             |
| Interior Floor 2    |      |               |                                 |      |             |
| Heat Fuel           | 02   | Oil           |                                 |      |             |
| Heat Type           | 05   | Hot Water     |                                 |      |             |
| AC Type             | 01   | None          |                                 |      |             |
| Bedrooms            | 4    |               |                                 |      |             |
| Full Baths          | 3    |               |                                 |      |             |
| Half Baths          | 1    |               |                                 |      |             |
| Extra Fixtures      | 1    |               |                                 |      |             |
| Total Rooms         | 8    |               |                                 |      |             |
| Bath Style          | 02   | Average       |                                 |      |             |
| Kitchen Style       | 02   | Average       |                                 |      |             |
| Extra Kitchens      | 0    |               |                                 |      |             |
| Fireplaces          | 2    |               |                                 |      |             |
| Extra Openings      | 1    |               |                                 |      |             |
| Gas Fireplaces      | 0    |               |                                 |      |             |
| Sq Ft Fin Bsmt      | 1356 |               |                                 |      |             |
| FBM Quality         | 04   | Above Average |                                 |      |             |
| Foundation          | 06   | Poured Conc   |                                 |      |             |
| Bsmt Garage         | 0    |               |                                 |      |             |
| Bsmt Area           | 1944 |               |                                 |      |             |

| CONDO DATA  |      |             |         |   |
|-------------|------|-------------|---------|---|
| Parcel Id   |      | C           | Owne    |   |
|             |      |             | B       | S |
| Adjust Type | Code | Description | Factor% |   |
| Condo Flr   |      |             |         |   |
| Condo Unit  |      |             |         |   |

| COST / MARKET VALUATION  |         |  |  |
|--------------------------|---------|--|--|
| Net Other Adj            | 851,415 |  |  |
| Replace Cost             | 942,775 |  |  |
| Year Built               | 1970    |  |  |
| Effective Year Built     | 1997    |  |  |
| Depreciation Code        | G       |  |  |
| Remodel Rating           |         |  |  |
| Year Remodeled           |         |  |  |
| Depreciation %           | 24      |  |  |
| Functional Obsol         |         |  |  |
| External Obsol           |         |  |  |
| Trend Factor             | 1.000   |  |  |
| Condition                |         |  |  |
| Condition %              |         |  |  |
| Percent Good             | 76      |  |  |
| Cns Sect Rcnd            | 716,500 |  |  |
| Dep % Ovr                |         |  |  |
| Dep Ovr Comment          |         |  |  |
| Misc Imp Ovr             |         |  |  |
| Misc Imp Ovr Comment     |         |  |  |
| Cost to Cure Ovr         |         |  |  |
| Cost to Cure Ovr Comment |         |  |  |

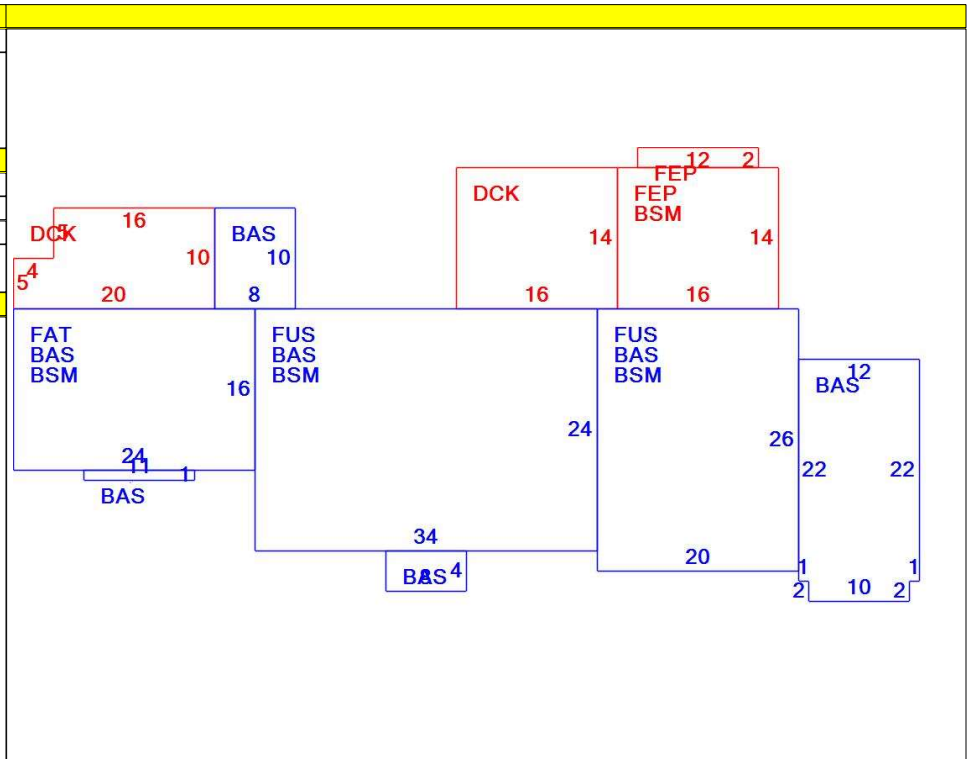

**OB - OUTBUILDING & YARD ITEMS(L) / XF - BUILDING EXTRA FEATURES(B)**

| Code | Description    | L/B | Units | Unit Price | Yr Blt | Cond. Cd | % Gd | Grade | Grade Adj. | Appr. Value |
|------|----------------|-----|-------|------------|--------|----------|------|-------|------------|-------------|
| SHD1 | Shed           | L   | 64    | 21.00      | 1980   | A        | 70   | C     | 1.00       | 900         |
| FGR1 | Garage - 1 Sto | L   | 528   | 52.00      | 1997   | A        | 70   | C     | 1.00       | 19,200      |

**BUILDING SUB-AREA SUMMARY SECTION**

| Code                       | Description             | Living Area | Floor Area | Eff Area | Unit Cost | Undeprec Value |
|----------------------------|-------------------------|-------------|------------|----------|-----------|----------------|
| BAS                        | First Floor             | 2,127       | 2,127      | 2,127    | 204.86    | 435,746        |
| BSM                        | Basement                | 0           | 1,944      | 389      | 40.99     | 79,692         |
| DCK                        | Deck                    | 0           | 404        | 40       | 20.28     | 8,195          |
| FAT                        | Finished Attic          | 115         | 384        | 115      | 61.35     | 23,559         |
| FEP                        | Finished Enclosed Porch | 0           | 248        | 149      | 123.08    | 30,525         |
| FUS                        | Finished Upper Story    | 1,336       | 1,336      | 1,336    | 204.86    | 273,698        |
| Ttl Gross Liv / Lease Area |                         | 3,578       | 6,443      | 4,156    |           | 851,415        |

