

CURRENT OWNER		TOPO	UTILITIES	STRT / ROAD	LOCATION	CURRENT ASSESSMENT					
HUTCHINSON SCOTT T & LANCE S T JACQUELINE B HUTCHINSON IRREV PO BOX 113  DUXBURY MA 02331		0	Water	0	Arterial	0	Average	Description	Code	Appraised	Assessed
		0	No Sewer	0	Paved	0	Average	RESIDENTL	1010	842,300	842,300
				0	Heavy			RES LAND	1010	1,448,400	1,448,400
<b>SUPPLEMENTAL DATA</b>											
Alt Prcl ID Scnd Home Tax Class T Tot Fin Area 6919 Total Acres 1.221 Chapter Lan				Cyclical 9 Exemption W District Res Exem							
GIS ID F_880372_2835678				Assoc Pid#		Total 2,290,700 2,290,700					

905  
 DUXBURY, MA  
**VISION**

RECORD OF OWNERSHIP		BK-VOL/PAGE	SALE DATE	Q/U	V/I	SALE PRICE	VC	PREVIOUS ASSESSMENTS (HISTORY)										
HUTCHINSON SCOTT T & LANCE S TT		43089 0241	05-21-2013	U	I	1	1A	Year	Code	Assessed	Year	Code	Assessed V	Year	Code	Assessed		
HUTCHINSON ROBERT A		4084 0065	07-17-1975	U	I	91,180	1	2023	1010	887,700	2022	1010	811,200	2021	1010	658,100		
									1010	1,263,500		1010	859,700		1010	726,000		
Total										2,151,200	Total				1,670,900	Total		1,384,100

EXEMPTIONS				OTHER ASSESSMENTS				This signature acknowledges a visit by a Data Collector or Assessor										
Year	Code	Description	Amount	Code	Description	Number	Amount	Comm Int										
			Total				0.00											
ASSESSING NEIGHBORHOOD										APPRAISED VALUE SUMMARY								
Nbhd		Nbhd Name		B		Tracing		Batch		Appraised Bldg. Value (Card)						842,300		
0090										Appraised Xf (B) Value (Bldg)						0		
										Appraised Ob (B) Value (Bldg)						0		
										Appraised Land Value (Bldg)						1,448,400		
										Special Land Value						0		
										Total Appraised Parcel Value						2,290,700		
										Valuation Method						C		
										Total Appraised Parcel Value						2,290,700		

BUILDING PERMIT RECORD										VISIT / CHANGE HISTORY					
Permit Id	Issue Date	Type	Description	Amount	Insp Date	% Comp	Date Comp	Comments		Date	Id	Type	Is	Cd	Purpose/Result
219	12-20-2011	MN	Maintenance	2,500		100		WINDOW		02-05-2020	SJD	0	1	00	Measure & Listed
										04-12-2013	VGS			20	Field Review
										05-21-2008	BSB		1	00	Measure & Listed

LAND LINE VALUATION SECTION																	
B	Use Code	Description	Zone	Land Type	Land Units	Unit Price	Size Adj	Site Index	Cond.	Nbhd.	Nbhd. Adj	Notes	Location Adjustment		Adj Unit P	Land Value	
1	1010	Single Family	RC	Primary	40,000	SF 8.75	1.00000	5	1.00	0090	3.661		V110	1.1000	35.24	1,409,500	
1	1010	Single Family	RC	Residual	0.304	AC 35,000.00	1.00000	5	1.00	0090	3.661			1.0000	2.94	38,900	
Total Card Land Units					1.22	AC	Parcel Total Land Area					1.22	Total Land Value				1,448,400

CONSTRUCTION DETAIL			CONSTRUCTION DETAIL (CONTINUED)		
Element	Cd	Description	Element	Cd	Description
Style	03	Colonial	Bsmt Area	2007	
Model	01	Residential	Bsmt Type	03	
Grade	09	Custom	Unfin Area	0.00	Partial
Stories	2.65				
Occupancy	1				
Exterior Wall 1	14	Wood Shingle			
Exterior Wall 2					
Roof Structure	07	Gambrel			
Roof Cover	03	Asphalt			
Interior Wall 1	05	Drywall			
Interior Wall 2					
Interior Floor 1	09	Pine/Soft Wood			
Interior Floor 2					
Heat Fuel	03	Gas			
Heat Type	04	Forced Air-Duc			
AC Type	01	None			
Bedrooms	5				
Full Baths	4				
Half Baths	1				
Extra Fixtures	3				
Total Rooms	13				
Bath Style	01	Old Style			
Kitchen Style	01	Old Style			
Extra Kitchens	0				
Fireplaces	3				
Extra Openings	2				
Gas Fireplaces	0				
Sq Ft Fin Bsmt	0				
FBM Quality					
Foundation	03	Stone			
Bsmt Garage	2				
Bsmt Area	2007				

CONDO DATA				
Parcel Id		C	Owne	
			B	S
Adjust Type	Code	Description	Factor%	
Condo Flr				
Condo Unit				

COST / MARKET VALUATION		
Net Other Adj		1,556,472
Replace Cost		63,270
Year Built		1,619,741
Effective Year Built		1893
Depreciation Code		1973
Remodel Rating		F
Year Remodeled		
Depreciation %		48
Functional Obsol		
External Obsol		
Trend Factor		1.000
Condition		
Condition %		
Percent Good		52
Cns Sect Rcnd		842,300
Dep % Ovr		
Dep Ovr Comment		
Misc Imp Ovr		
Misc Imp Ovr Comment		
Cost to Cure Ovr		
Cost to Cure Ovr Comment		

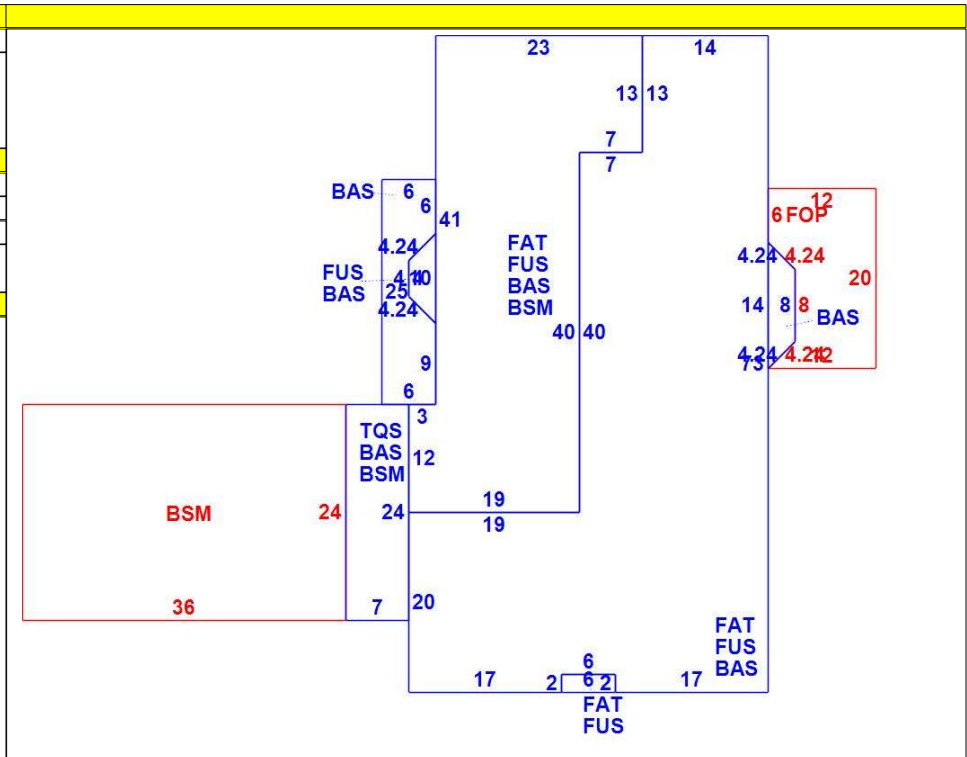

OB - OUTBUILDING & YARD ITEMS(L) / XF - BUILDING EXTRA FEATURES(B)										
Code	Description	L/B	Units	Unit Price	Yr Blt	Cond. Cd	% Gd	Grade	Grade Adj.	Appr. Value

BUILDING SUB-AREA SUMMARY SECTION						
Code	Description	Living Area	Floor Area	Eff Area	Unit Cost	Undeprec Value
BAS	First Floor	3,136	3,136	3,136	211.74	664,004
BSM	Basement	0	2,007	401	42.31	84,906
FAT	Finished Attic	839	2,797	839	63.51	177,647
FOP	Open Porch	0	207	31	31.71	6,564
FUS	Finished Upper Story	2,818	2,818	2,818	211.74	596,672
TQS	Three Quarter Story	126	168	126	158.80	26,679
Ttl Gross Liv / Lease Area		6,919	11,133	7,351		1,556,472

