

| CURRENT OWNER | | TOPO | UTILITIES | STRT / ROAD | LOCATION | CURRENT ASSESSMENT | | | | |
|--------------------------|--|-----------------------|-------------------------|--------------|------------|--------------------|-------|-----------|-----------|------------------------|
| COLLEARY W HEATHER | | | 0 Water | 0 Cul-De-Sac | 0 Average | Description | Code | Appraised | Assessed | 905 DUXBURY, MA |
| COLLEARY JAMES | | | 0 No Sewer | 0 Paved | 0 Average | RESIDNTL | 1010 | 1,030,400 | 1,030,400 | |
| 51 AMOS SAMPSON LN | | | | 0 Light | | RES LAND | 1010 | 526,600 | 526,600 | |
| SUPPLEMENTAL DATA | | | | | | | | | | |
| DUXBURY MA 02332 | | Alt Prcl ID | Cyclical Exemption W | | 9 | RESIDNTL | 1010 | 43,600 | 43,600 | VISION |
| | | Scnd Home Tax Class T | District Res Exem | | | | | | | |
| | | Tot Fin Area 4603 | Chapter Lan | | | | | | | |
| | | Total Acres .928 | GIS ID F_877755_2837092 | | Assoc Pid# | | | | | |
| | | | | | | | Total | 1,600,600 | 1,600,600 | |

| RECORD OF OWNERSHIP | | BK-VOL/PAGE | SALE DATE | Q/U | V/I | SALE PRICE | VC | PREVIOUS ASSESSMENTS (HISTORY) | | | | | | | | |
|---------------------|-------|-------------|------------|-----|-----|------------|-------|--------------------------------|------|----------|-----------|------|----------|-----------|------|----------|
| COLLEARY W HEATHER | 53362 | 252 | 09-01-2020 | U | I | 1,200,000 | 1 | Year | Code | Assessed | Year | Code | Assessed | Year | Code | Assessed |
| JACOBSON EILEEN M | 37560 | 0031 | 07-31-2009 | Q | I | 1,025,000 | 00 | 2023 | 1010 | 780,500 | 2022 | 1010 | 916,600 | 2021 | 1010 | 778,000 |
| MYDLACK SARA TT | 36469 | 0012 | 10-23-2008 | U | I | 1 | 1A | | 1010 | 626,300 | | 1010 | 482,900 | | 1010 | 405,200 |
| PINEAU ROBERT M | 10626 | 0005 | 12-09-1991 | Q | V | 129,500 | 00 | | 1010 | 27,000 | | 1010 | 27,000 | | 1010 | 27,600 |
| | | | | | | | Total | 1,433,800 | | Total | 1,426,500 | | Total | 1,210,800 | | |

| EXEMPTIONS | | | OTHER ASSESSMENTS | | | | | |
|------------|------|-------------|-------------------|------|-------------|--------|--------|----------|
| Year | Code | Description | Amount | Code | Description | Number | Amount | Comm Int |
| | | Total | 0.00 | | | | | |

| ASSESSING NEIGHBORHOOD | | | | |
|------------------------|-----------|---|---------|-------|
| Nbhd | Nbhd Name | B | Tracing | Batch |
| 0080 | | | | |

| APPRAISED VALUE SUMMARY | | | | | | | | | | | | | | |
|-------------------------------|--|--|--|--|--|--|--|--|--|-----------|--|--|--|--|
| Appraised Bldg. Value (Card) | | | | | | | | | | 1,030,400 | | | | |
| Appraised Xf (B) Value (Bldg) | | | | | | | | | | 0 | | | | |
| Appraised Ob (B) Value (Bldg) | | | | | | | | | | 43,600 | | | | |
| Appraised Land Value (Bldg) | | | | | | | | | | 526,600 | | | | |
| Special Land Value | | | | | | | | | | 0 | | | | |
| Total Appraised Parcel Value | | | | | | | | | | 1,600,600 | | | | |
| Valuation Method | | | | | | | | | | C | | | | |
| Total Appraised Parcel Value | | | | | | | | | | 1,600,600 | | | | |

| BUILDING PERMIT RECORD | | | | | | | | | | VISIT / CHANGE HISTORY | | | | | |
|------------------------|------------|------|---------------|--------|------------|--------|-----------|----------------------|--|------------------------|-----|------|----|----|-----------------------|
| Permit Id | Issue Date | Type | Description | Amount | Insp Date | % Comp | Date Comp | Comments | | Date | Id | Type | Is | Cd | Purpose/Result |
| 17 | 10-19-2001 | AD | Addition | 2,500 | 10-21-2002 | 100 | | 5X12 STORAGE SHED | | 05-26-2021 | SJD | 9 | 1 | 07 | Measure - Info @ Door |
| 19990519 | 11-15-1999 | NC | New Construct | 26,000 | 07-07-2000 | 100 | | INGRD GUNITE POOL | | 04-12-2013 | VGS | | | 20 | Field Review |
| 14080 | 06-12-1996 | NC | New Construct | 11,000 | 09-03-1997 | 100 | | 16X18 ROOFED PORCH | | 12-11-2009 | KP | | 1 | 00 | Measure & Listed |
| 12175 | 10-31-1991 | NC | New Construct | 20,400 | | 100 | | 2STY W/ELL-GAR,DK,PH | | | | | | | |

| LAND LINE VALUATION SECTION | | | | | | | | | | | | | | | | |
|-----------------------------|----------|---------------|------|-----------|------------|------------|------------------------|------------|-------|-------|-----------|-------|---------------------|------------|------------|---------|
| B | Use Code | Description | Zone | Land Type | Land Units | Unit Price | Size Adj | Site Index | Cond. | Nbhd. | Nbhd. Adj | Notes | Location Adjustment | Adj Unit P | Land Value | |
| 1 | 1010 | Single Family | RC | Primary | 40,000 | SF | 8.75 | 1.00000 | 5 | 1.00 | 0080 | 1.503 | | 1.0002 | 13.15 | 526,100 |
| 1 | 1010 | Single Family | RC | Residual | 0.010 | AC | 35,000.00 | 1.00000 | 5 | 1.00 | 0080 | 1.503 | | 1.0000 | 1.15 | 500 |
| Total Card Land Units | | | | | 0.93 | AC | Parcel Total Land Area | | | | | 0.93 | Total Land Value | | | 526,600 |

| CONSTRUCTION DETAIL | | | CONSTRUCTION DETAIL (CONTINUED) | | |
|---------------------|------|---------------|---------------------------------|------|-------------|
| Element | Cd | Description | Element | Cd | Description |
| Style | 03 | Colonial | Bsmt Area | 1806 | |
| Model | 01 | Residential | Bsmt Type | 04 | |
| Grade | 08 | Excellent | Unfin Area | 0.00 | Full |
| Stories | 2.35 | | | | |
| Occupancy | 1 | | | | |
| Exterior Wall 1 | 11 | Clapboard | | | |
| Exterior Wall 2 | | | | | |
| Roof Structure | 04 | Hip | | | |
| Roof Cover | 03 | Asphalt | | | |
| Interior Wall 1 | 05 | Drywall | | | |
| Interior Wall 2 | | | | | |
| Interior Floor 1 | 12 | Hardwood | | | |
| Interior Floor 2 | | | | | |
| Heat Fuel | 02 | Oil | | | |
| Heat Type | 05 | Hot Water | | | |
| AC Type | 03 | Central | | | |
| Bedrooms | 5 | | | | |
| Full Baths | 3 | | | | |
| Half Baths | 0 | | | | |
| Extra Fixtures | 2 | | | | |
| Total Rooms | 11 | | | | |
| Bath Style | 02 | Average | | | |
| Kitchen Style | 02 | Average | | | |
| Extra Kitchens | 0 | | | | |
| Fireplaces | 1 | | | | |
| Extra Openings | 0 | | | | |
| Gas Fireplaces | 0 | | | | |
| Sq Ft Fin Bsmt | 300 | | | | |
| FBM Quality | 04 | Above Average | | | |
| Foundation | 06 | Poured Conc | | | |
| Bsmt Garage | 0 | | | | |
| Bsmt Area | 1806 | | | | |

| CONDO DATA | | | |
|-------------|------|-------------|---------|
| Parcel Id | C | Owne | |
| | | B | S |
| Adjust Type | Code | Description | Factor% |
| Condo Flr | | | |
| Condo Unit | | | |

| COST / MARKET VALUATION | |
|--------------------------|-----------|
| Net Other Adj | 1,168,325 |
| Replace Cost | 43,925 |
| Year Built | 1,212,250 |
| Effective Year Built | 1992 |
| Depreciation Code | 2006 |
| Remodel Rating | G |
| Year Remodeled | |
| Depreciation % | 15 |
| Functional Obsol | |
| External Obsol | |
| Trend Factor | 1.000 |
| Condition | |
| Condition % | |
| Percent Good | 85 |
| Cns Sect Rcnld | 1,030,400 |
| Dep % Ovr | |
| Dep Ovr Comment | |
| Misc Imp Ovr | |
| Misc Imp Ovr Comment | |
| Cost to Cure Ovr | |
| Cost to Cure Ovr Comment | |

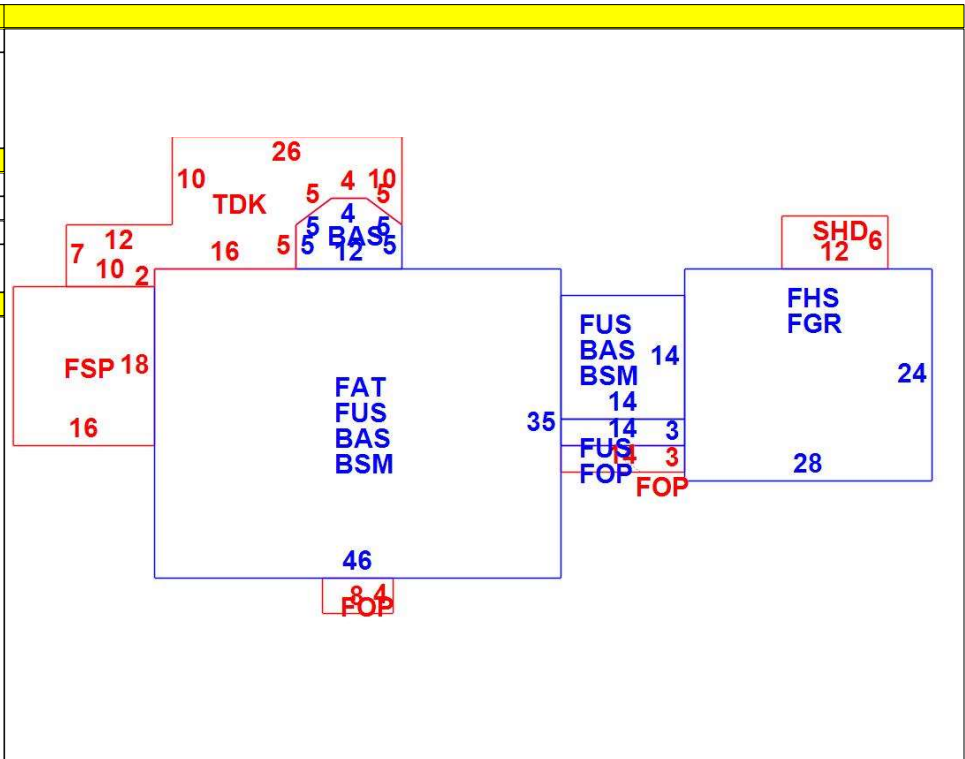

OB - OUTBUILDING & YARD ITEMS(L) / XF - BUILDING EXTRA FEATURES(B)

| Code | Description | L/B | Units | Unit Price | Yr Blt | Cond. Cd | % Gd | Grade | Grade Adj. | Appr. Value |
|------|---------------|-----|-------|------------|--------|----------|------|-------|------------|-------------|
| SPL2 | Ing Pool-Good | L | 700 | 89.00 | 1999 | A | 70 | C | 1.00 | 43,600 |

BUILDING SUB-AREA SUMMARY SECTION

| Code | Description | Living Area | Floor Area | Eff Area | Unit Cost | Undeprec Value |
|----------------------------|----------------------|-------------|------------|----------|-----------|----------------|
| BAS | First Floor | 1,890 | 1,890 | 1,890 | 219.36 | 414,595 |
| BSM | Basement | 0 | 1,806 | 361 | 43.85 | 79,190 |
| FAT | Finished Attic | 483 | 1,610 | 483 | 65.81 | 105,952 |
| FGR | Garage | 0 | 672 | 269 | 87.81 | 59,009 |
| FHS | Finished Half Story | 336 | 672 | 336 | 109.68 | 73,706 |
| FOP | Open Porch | 0 | 116 | 17 | 32.15 | 3,729 |
| FSP | Screened Porch | 0 | 288 | 58 | 44.18 | 12,723 |
| FUS | Finished Upper Story | 1,848 | 1,848 | 1,848 | 219.36 | 405,382 |
| SHD | Attached Shed | 0 | 72 | 25 | 76.17 | 5,484 |
| TDK | Trex Deck | 0 | 386 | 39 | 22.16 | 8,555 |
| Ttl Gross Liv / Lease Area | | 4,557 | 9,360 | 5,326 | | 1,168,325 |

