

CURRENT OWNER		TOPO	UTILITIES	STRT / ROAD	LOCATION	CURRENT ASSESSMENT				
WHITE CHARLES B			0 Water	0 Private	0 Average	Description	Code	Appraised	Assessed	905 DUXBURY, MA
WHITE DENISE E			0 No Sewer	0 Paved	0 Average	RESIDNTL	1010	779,800	779,800	
381 WASHINGTON ST				0 Light		RES LAND	1010	1,160,400	1,160,400	
DUXBURY MA 02332						RESIDNTL	1010	16,000	16,000	
SUPPLEMENTAL DATA										VISION
Alt Prcl ID Scnd Home Tax Class T Tot Fin Area 4195 Total Acres .53 Chapter Lan GIS ID F_881064_2838943			Cyclical 8 Exemption W District Res Exem Assoc Pid#			Total 1,956,200 1,956,200				

RECORD OF OWNERSHIP		BK-VOL/PAGE	SALE DATE	Q/U	V/I	SALE PRICE	VC	PREVIOUS ASSESSMENTS (HISTORY)								
WHITE CHARLES B	25488	0013	06-18-2003	Q	I	875,000	00	Year	Code	Assessed	Year	Code	Assessed			
								2023	1010	579,900	2022	1010	482,400			
									1010	1,011,200		1010	695,400			
									1010	12,300		1010	12,300			
Total								1,603,400		Total		1,190,100		Total		1,025,400

EXEMPTIONS			OTHER ASSESSMENTS					
Year	Code	Description	Amount	Code	Description	Number	Amount	Comm Int
Total		0.00						

ASSESSING NEIGHBORHOOD				
Nbhd	Nbhd Name	B	Tracing	Batch
0090				

NOTES									
This signature acknowledges a visit by a Data Collector or Assessor									

APPRAISED VALUE SUMMARY									
Appraised Bldg. Value (Card)									779,800
Appraised Xf (B) Value (Bldg)									0
Appraised Ob (B) Value (Bldg)									16,000
Appraised Land Value (Bldg)									1,160,400
Special Land Value									0
Total Appraised Parcel Value									1,956,200
Valuation Method									C
Total Appraised Parcel Value									1,956,200

BUILDING PERMIT RECORD										VISIT / CHANGE HISTORY					
Permit Id	Issue Date	Type	Description	Amount	Insp Date	% Comp	Date Comp	Comments		Date	Id	Type	Is	Cd	Purpose/Result
QPO-21-29 15297	11-15-2021 02-01-1999	MN MN	Maintenance Maintenance	26,000 10,000		100 100	11-15-2021	NEW ROOF STRIP AND REROOF		04-12-2013 07-07-1999	VGS BSB		1	20 00	Field Review Measure & Listed

LAND LINE VALUATION SECTION																
B	Use Code	Description	Zone	Land Type	Land Units	Unit Price	Size Adj	Site Index	Cond.	Nbhd.	Nbhd. Adj	Notes	Location Adjustment	Adj Unit P	Land Value	
1	1010	Single Family	RC	Primary	23,087	SF 13.73	1.00000	5	1.00	0090	3.661		1.0000	50.26	1,160,400	
Total Card Land Units					0.53	AC	Parcel Total Land Area					0.53	Total Land Value			1,160,400

CONSTRUCTION DETAIL			CONSTRUCTION DETAIL (CONTINUED)		
Element	Cd	Description	Element	Cd	Description
Style	04	Cape Cod	Bsmt Area	568	
Model	01	Residential	Bsmt Type	04	
Grade	08	Excellent	Unfin Area	287.00	Full
Stories	1.75				
Occupancy	1				
Exterior Wall 1	14	Wood Shingle			
Exterior Wall 2					
Roof Structure	03	Gable			
Roof Cover	03	Asphalt			
Interior Wall 1	05	Drywall			
Interior Wall 2					
Interior Floor 1	12	Hardwood			
Interior Floor 2					
Heat Fuel	03	Gas			
Heat Type	05	Hot Water			
AC Type	01	None			
Bedrooms	6				
Full Baths	3				
Half Baths	0				
Extra Fixtures	0				
Total Rooms	11				
Bath Style	02	Average			
Kitchen Style	02	Average			
Extra Kitchens	0				
Fireplaces	2				
Extra Openings	0				
Gas Fireplaces	0				
Sq Ft Fin Bsmt	0				
FBM Quality					
Foundation	06	Poured Conc			
Bsmt Garage	0				
Bsmt Area	568				

CONDO DATA			
Parcel Id		C	Owne
			B S
Adjust Type	Code	Description	Factor%
Condo Flr			
Condo Unit			

COST / MARKET VALUATION	
Net Other Adj	1,049,846
Replace Cost	33,250
Year Built	1,083,095
Effective Year Built	1935
Depreciation Code	1993
Remodel Rating	G
Year Remodeled	
Depreciation %	28
Functional Obsol	
External Obsol	
Trend Factor	1.000
Condition	
Condition %	
Percent Good	72
Cns Sect Rcnld	779,800
Dep % Ovr	
Dep Ovr Comment	
Misc Imp Ovr	
Misc Imp Ovr Comment	
Cost to Cure Ovr	
Cost to Cure Ovr Comment	

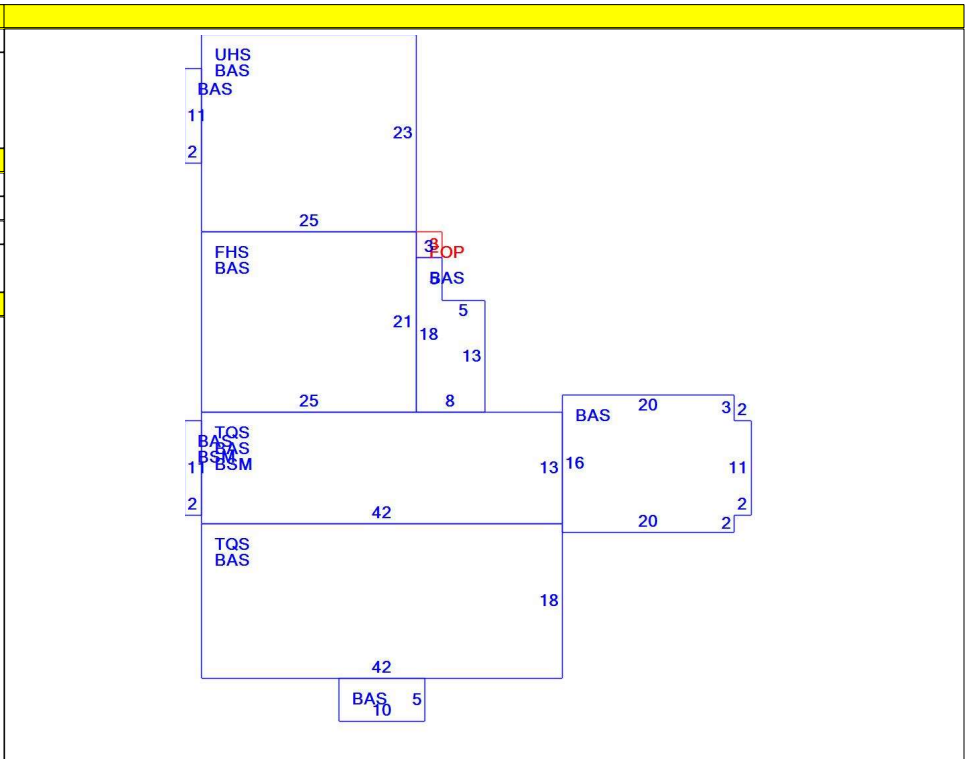

OB - OUTBUILDING & YARD ITEMS(L) / XF - BUILDING EXTRA FEATURES(B)

Code	Description	L/B	Units	Unit Price	Yr Blt	Cond. Cd	% Gd	Grade	Grade Adj.	Appr. Value
FGR1	Garage - 1 Sto	L	440	52.00	1980	A	70	C	1.00	16,000

BUILDING SUB-AREA SUMMARY SECTION

Code	Description	Living Area	Floor Area	Eff Area	Unit Cost	Undeprec Value
BAS	First Floor	2,957	2,957	2,957	235.60	696,677
BSM	Basement	0	568	114	47.29	26,859
FHS	Finished Half Story	263	525	263	118.03	61,963
FOP	Open Porch	0	9	1	26.18	236
TQS	Three Quarter Story	977	1,302	977	176.79	230,184
UHS	Unfinished Half Story	0	575	144	59.00	33,927
Ttl Gross Liv / Lease Area		4,197	5,936	4,456		1,049,846



381 WASHINGTON ST

