

| CURRENT OWNER | | TOPO | UTILITIES | STRT / ROAD | LOCATION | CURRENT ASSESSMENT | | | |
|--------------------------|--|--------------------------|------------|-------------|-----------|--------------------|------|-----------|-----------|
| BONE ELIZABETH H TRUSTEE | | | 0 Water | 0 Dead End | 0 Average | Description | Code | Appraised | Assessed |
| ELIZABETH H BONE TRUST | | | 0 No Sewer | 0 Paved | 0 Average | RESIDNTL | 1010 | 489,100 | 489,100 |
| PO BOX 356 | | | | 0 Light | | RES LAND | 1010 | 1,238,200 | 1,238,200 |
| DUXBURY MA 02331 | | SUPPLEMENTAL DATA | | | | RESIDNTL | 1010 | 19,700 | 19,700 |
| Alt Prcl ID | | Cyclical | | 9 | | | | | |
| Scnd Home | | Exemption | | | | | | | |
| Tax Class T | | W | | | | | | | |
| Tot Fin Area 1840 | | District | | | | | | | |
| Total Acres .16 | | Res Exem | | | | | | | |
| Chapter Lan | | | | | | | | | |
| GIS ID F_880943_2836477 | | Assoc Pid# | | | | | | | |
| | | | | | | Total | | 1,747,000 | 1,747,000 |

905
 DUXBURY, MA
VISION

| RECORD OF OWNERSHIP | | BK-VOL/PAGE | SALE DATE | Q/U | V/I | SALE PRICE | VC | PREVIOUS ASSESSMENTS (HISTORY) | | | | | |
|--------------------------|--|-------------|------------|-----|-----|------------|----|--------------------------------|-------|-----------|---------|-------|----------|
| BONE ELIZABETH H TRUSTEE | | 52134 75 | 12-23-2019 | U | I | 100 | 1A | Year | Code | Assessed | Year | Code | Assessed |
| BONE SCOTT C | | 14211 0070 | 03-15-1996 | Q | I | 280,000 | 00 | 2023 | 1010 | 371,600 | 2022 | 1010 | 339,800 |
| | | | | | | | | | 1010 | 1,028,700 | | 1010 | 622,000 |
| | | | | | | | | | 1010 | 7,600 | | 1010 | 7,600 |
| | | | | | | Total | | 1,407,900 | Total | | 969,400 | Total | 904,200 |

| EXEMPTIONS | | | | OTHER ASSESSMENTS | | | | This signature acknowledges a visit by a Data Collector or Assessor | | | | |
|------------|------|-------------|--------|-------------------|-------------|--------|--------|---|--|--|--|--|
| Year | Code | Description | Amount | Code | Description | Number | Amount | Comm Int | | | | |
| | | | | | | | | | | | | |
| | | | Total | | | | 0.00 | | | | | |

| ASSESSING NEIGHBORHOOD | | | | APPRaised VALUE SUMMARY | | | | |
|------------------------|-----------|---|---------|-------------------------|-------------------------------|--|--|-----------|
| Nbhd | Nbhd Name | B | Tracing | Batch | | | | |
| 0090 | | | | | Appraised Bldg. Value (Card) | | | 489,100 |
| | | | | | Appraised Xf (B) Value (Bldg) | | | 0 |
| | | | | | Appraised Ob (B) Value (Bldg) | | | 19,700 |
| | | | | | Appraised Land Value (Bldg) | | | 1,238,200 |
| | | | | | Special Land Value | | | 0 |
| | | | | | Total Appraised Parcel Value | | | 1,747,000 |
| | | | | | Valuation Method | | | C |
| | | | | | Total Appraised Parcel Value | | | 1,747,000 |

| BUILDING PERMIT RECORD | | | | | | | | | | VISIT / CHANGE HISTORY | | | | | |
|------------------------|------------|------|-------------|--------|------------|--------|-----------|----------------------------------|--|------------------------|-----|------|----|----|--------------------|
| Permit Id | Issue Date | Type | Description | Amount | Insp Date | % Comp | Date Comp | Comments | | Date | Id | Type | Is | Cd | Purpose/Result |
| BP-20-19 | 01-27-2020 | BP | | 10,400 | 08-26-2020 | 100 | | Refurb 1st & 2nd floor bathrooms | | 08-26-2020 | SJT | 5 | | 20 | Field Review |
| 14209 | 09-05-1996 | DM | Demolish | 2,000 | | 100 | | 12X33 DECK | | 04-12-2013 | VGS | | | 20 | Field Review |
| | | | | | | | | | | 07-15-2008 | BSB | | | 01 | Measure - No Entry |

| LAND LINE VALUATION SECTION | | | | | | | | | | | | | | | | |
|-----------------------------|----------|---------------|------|-----------|-----------------------|------------|----------|------------------------|-------|-------|-----------|-------|---------------------|------------|------------|-----------|
| B | Use Code | Description | Zone | Land Type | Land Units | Unit Price | Size Adj | Site Index | Cond. | Nbhd. | Nbhd. Adj | Notes | Location Adjustment | Adj Unit P | Land Value | |
| 1 | 1010 | Single Family | RC | Primary | 6,970 SF | 34.66 | 1.00000 | 5 | 1.00 | 0090 | 3.661 | | L140 | 1.4000 | 177.65 | 1,238,200 |
| | | | | | Total Card Land Units | 0.16 | AC | Parcel Total Land Area | | | | 0.16 | Total Land Value | | | 1,238,200 |

| CONSTRUCTION DETAIL | | | | CONSTRUCTION DETAIL (CONTINUED) | | | |
|---------------------|-----|--------------|------------|---------------------------------|-------------|--|--|
| Element | Cd | Description | Element | Cd | Description | | |
| Style | 03 | Colonial | Bsmt Area | 724 | | | |
| Model | 01 | Residential | Bsmt Type | 04 | | | |
| Grade | 08 | Excellent | Unfin Area | 0.00 | Full | | |
| Stories | 2 | | | | | | |
| Occupancy | 1 | | | | | | |
| Exterior Wall 1 | 14 | Wood Shingle | | | | | |
| Exterior Wall 2 | | | | | | | |
| Roof Structure | 07 | Gambrel | | | | | |
| Roof Cover | 03 | Asphalt | | | | | |
| Interior Wall 1 | 05 | Drywall | | | | | |
| Interior Wall 2 | | | | | | | |
| Interior Floor 1 | 12 | Hardwood | | | | | |
| Interior Floor 2 | | | | | | | |
| Heat Fuel | 02 | Oil | | | | | |
| Heat Type | 05 | Hot Water | | | | | |
| AC Type | 01 | None | | | | | |
| Bedrooms | 3 | | | | | | |
| Full Baths | 2 | | | | | | |
| Half Baths | 0 | | | | | | |
| Extra Fixtures | 3 | | | | | | |
| Total Rooms | 6 | | | | | | |
| Bath Style | 02 | Average | | | | | |
| Kitchen Style | 02 | Average | | | | | |
| Extra Kitchens | 0 | | | | | | |
| Fireplaces | 1 | | | | | | |
| Extra Openings | 0 | | | | | | |
| Gas Fireplaces | 0 | | | | | | |
| Sq Ft Fin Bsmt | 0 | | | | | | |
| FBM Quality | | | | | | | |
| Foundation | 05 | Conc Block | | | | | |
| Bsmt Garage | 0 | | | | | | |
| Bsmt Area | 724 | | | | | | |

| CONDO DATA | | | |
|-------------|------|-------------|---------|
| Parcel Id | | C | Owne |
| | | B | S |
| Adjust Type | Code | Description | Factor% |
| Condo Flr | | | |
| Condo Unit | | | |

| COST / MARKET VALUATION | |
|--------------------------|---------|
| Net Other Adj | 562,277 |
| Replace Cost | 26,950 |
| Year Built | 1935 |
| Effective Year Built | 2004 |
| Depreciation Code | E |
| Remodel Rating | |
| Year Remodeled | |
| Depreciation % | 17 |
| Functional Obsol | |
| External Obsol | |
| Trend Factor | 1.000 |
| Condition | |
| Condition % | |
| Percent Good | 83 |
| Cns Sect Rcnld | 489,100 |
| Dep % Ovr | |
| Dep Ovr Comment | |
| Misc Imp Ovr | |
| Misc Imp Ovr Comment | |
| Cost to Cure Ovr | |
| Cost to Cure Ovr Comment | |

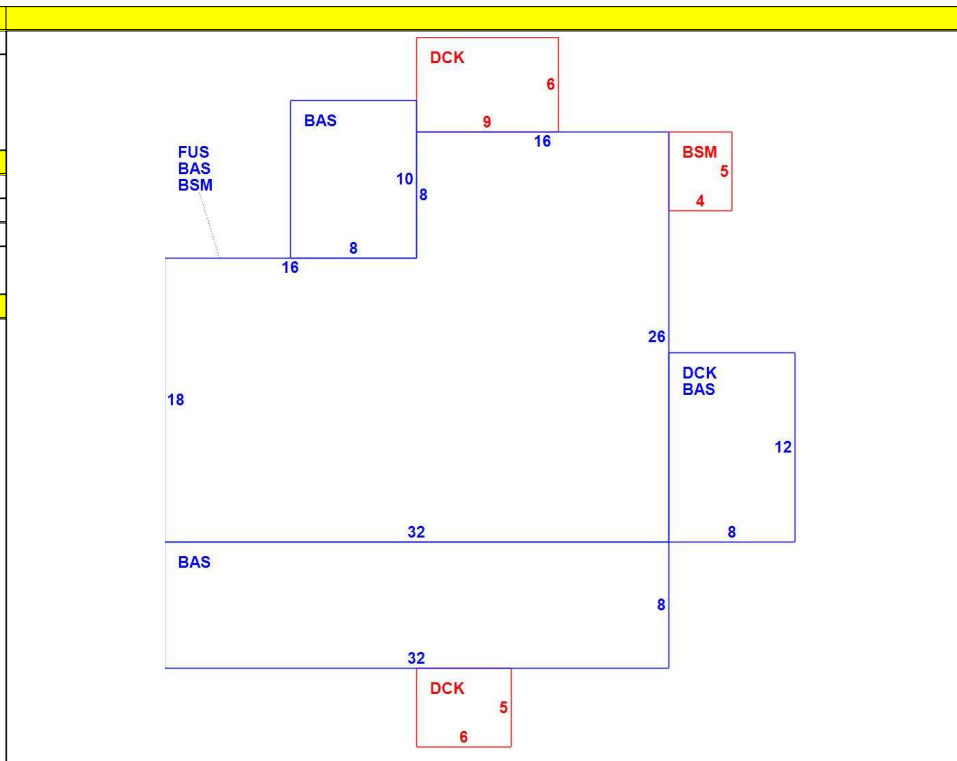

| OB - OUTBUILDING & YARD ITEMS(L) / XF - BUILDING EXTRA FEATURES(B) | | | | | | | | | | |
|--|----------------|-----|-------|------------|--------|----------|------|-------|------------|-------------|
| Code | Description | L/B | Units | Unit Price | Yr Blt | Cond. Cd | % Gd | Grade | Grade Adj. | Appr. Value |
| FGR1 | Garage - 1 Sto | L | 240 | 52.00 | 1980 | A | 70 | C | 1.00 | 8,700 |
| HTB | Hot Tub | L | 1 | 10500.00 | 2000 | A | 70 | B | 1.50 | 11,000 |

| BUILDING SUB-AREA SUMMARY SECTION | | | | | | |
|-----------------------------------|----------------------|-------------|------------|----------|-----------|----------------|
| Code | Description | Living Area | Floor Area | Eff Area | Unit Cost | Undeprec Value |
| BAS | First Floor | 1,136 | 1,136 | 1,136 | 280.72 | 318,895 |
| BSM | Basement | 0 | 724 | 145 | 56.22 | 40,704 |
| DCK | Deck | 0 | 180 | 18 | 28.07 | 5,053 |
| FUS | Finished Upper Story | 704 | 704 | 704 | 280.72 | 197,625 |
| Ttl Gross Liv / Lease Area | | 1,840 | 2,744 | 2,003 | | 562,277 |

