

| CURRENT OWNER | | TOPO | | UTILITIES | | STRT / ROAD | | LOCATION | | CURRENT ASSESSMENT | | | | 905 DUXBURY, MA | | | | | |
|---|--------------------------|--------------------------|-------------|---|------------|----------------------------------|------------------------|---|--------|--------------------------|--------------|--|-------------------|--------------------------------|--------------------|----------------|---|--------------------|----------|
| NICHOLS PETER NICHOLS KATHLEEN 167 BAY RD DUXBURY MA 02332 | | | | 0 Water 0 No Sewer | | 0 Arterial 0 Paved 0 Heavy | | 0 Average 0 Average | | Description | Code | Appraised | Assessed | | | | | | |
| | | | | | | | | | | RESIDENTL | 1010 | 646,700 | 646,700 | VISION | | | | | |
| | | | | | | | | | | RES LAND | 1010 | 649,400 | 649,400 | | | | | | |
| SUPPLEMENTAL DATA | | | | | | | | | | | | | | | | | | | |
| Alt Prcl ID Scnd Home Tax Class T Tot Fin Area 2806 Total Acres .87 Chapter Lan GIS ID F_876165_2833004 | | | | Cyclical 7 Exemption W District Res Exem Assoc Pid# | | | | | | | | | | | | | | | |
| | | | | | | | | | | Total | | 1,296,100 | 1,296,100 | | | | | | |
| RECORD OF OWNERSHIP | | BK-VOL/PAGE | | SALE DATE | | Q/U | | VI | | SALE PRICE | | VC | | PREVIOUS ASSESSMENTS (HISTORY) | | | | | |
| NICHOLS PETER WILLIAMS VIRGINIA M | | 47319 0158 18564 0348 | | 08-15-2016 05-31-2000 | | Q I Q I | | | | 895,500 00 630,000 00 | | | | Year | Code | Assessed | Year | Code | Assessed |
| | | | | | | | | | | 2023 | 1010 1010 | 697,000 772,800 | 2022 | 1010 1010 | 606,500 598,000 | 2021 | 1010 1010 | 567,700 447,100 | |
| | | | | | | | | | | Total | | 1,469,800 | Total | | 1,204,500 | Total | | 1,014,800 | |
| EXEMPTIONS | | | | OTHER ASSESSMENTS | | | | This signature acknowledges a visit by a Data Collector or Assessor | | | | | | | | | | | |
| Year | Code | Description | | Amount | | Code | Description | Number | Amount | Comm Int | | | | | | | | | |
| | | | | Total | | 0.00 | | | | | | | | | | | | | |
| ASSESSING NEIGHBORHOOD | | | | | | | | | | | | APPRAISED VALUE SUMMARY | | | | | | | |
| Nbhd | | Nbhd Name | | B | | Tracing | | Batch | | | | | | | | | | | |
| 0080 | | | | | | | | | | | | | | | | | | | |
| NOTES | | | | | | | | | | | | Appraised Bldg. Value (Card) 646,700 | | | | | | | |
| | | | | | | | | | | | | Appraised Xf (B) Value (Bldg) 0 | | | | | | | |
| | | | | | | | | | | | | Appraised Ob (B) Value (Bldg) 0 | | | | | | | |
| | | | | | | | | | | | | Appraised Land Value (Bldg) 649,400 | | | | | | | |
| | | | | | | | | | | | | Special Land Value 0 | | | | | | | |
| | | | | | | | | | | | | Total Appraised Parcel Value 1,296,100 | | | | | | | |
| | | | | | | | | | | | | Valuation Method C | | | | | | | |
| | | | | | | | | | | | | Total Appraised Parcel Value 1,296,100 | | | | | | | |
| BUILDING PERMIT RECORD | | | | | | | | | | | | VISIT / CHANGE HISTORY | | | | | | | |
| Permit Id | Issue Date | Type | Description | Amount | Insp Date | % Comp | Date Comp | Comments | | | | Date | Id | Type | Is | Cd | Purpose/Result | | |
| QP-19-184 2016-340 | 08-02-2019 10-13-2016 | MN AD | Addition | 3,000 14,640 | 06-14-2017 | 100 | 09-26-2019 | Maint -Reconfigure Deck CONSTRUCT Z 4' X 24' PORCH | | | | 06-14-2017 04-12-2013 06-24-2008 | SJD VGS BSB | 9 | | 07 20 00 | Measure - Info @ Door Field Review Measure & Listed | | |
| LAND LINE VALUATION SECTION | | | | | | | | | | | | | | | | | | | |
| B | Use Code | Description | Zone | Land Type | Land Units | Unit Price | Size Adj | Site Index | Cond. | Nbhd. | Nbhd. Adj | Notes | | Location Adjustment | | Adj Unit P | Land Value | | |
| 1 | 1010 | Single Family | RC | Primary | 37,897 SF | 9.12 | 1.00000 | 5 | 1.00 | 0080 | 1.503 | | | V125 | 1.2500 | 17.14 | 649,400 | | |
| Total Card Land Units | | | | | 0.87 | AC | Parcel Total Land Area | | | | | 0.87 | Total Land Value | | | | 649,400 | | |

| CONSTRUCTION DETAIL | | | CONSTRUCTION DETAIL (CONTINUED) | | |
|---------------------|------|----------------|---------------------------------|------|-------------|
| Element | Cd | Description | Element | Cd | Description |
| Style | 01 | Ranch | Bsmt Area | 2146 | |
| Model | 01 | Residential | Bsmt Type | 04 | |
| Grade | 08 | Excellent | Unfin Area | 0.00 | Full |
| Stories | 1 | | | | |
| Occupancy | 1 | | CONDO DATA | | |
| Exterior Wall 1 | 11 | Clapboard | Parcel Id | | C |
| Exterior Wall 2 | | | | | B |
| Roof Structure | 03 | Gable | Adjust Type | Code | Description |
| Roof Cover | 10 | Wood Shingle | Condo Flr | | |
| Interior Wall 1 | 05 | Drywall | Condo Unit | | |
| Interior Wall 2 | | | COST / MARKET VALUATION | | |
| Interior Floor 1 | 12 | Hardwood | | | 760,152 |
| Interior Floor 2 | | | Net Other Adj | | 28,525 |
| Heat Fuel | 03 | Gas | Replace Cost | | 788,678 |
| Heat Type | 04 | Forced Air-Duc | Year Built | | 1986 |
| AC Type | 03 | Central | Effective Year Built | | 2003 |
| Bedrooms | 3 | | Depreciation Code | | G |
| Full Baths | 2 | | Remodel Rating | | |
| Half Baths | 1 | | Year Remodeled | | |
| Extra Fixtures | 1 | | Depreciation % | | 18 |
| Total Rooms | 8 | | Functional Obsol | | |
| Bath Style | 02 | Average | External Obsol | | |
| Kitchen Style | 02 | Average | Trend Factor | | 1.000 |
| Extra Kitchens | 0 | | Condition | | |
| Fireplaces | 1 | | Condition % | | |
| Extra Openings | 0 | | Percent Good | | 82 |
| Gas Fireplaces | 0 | | Cns Sect Rcnd | | 646,700 |
| Sq Ft Fin Bsmt | 0 | | Dep % Ovr | | |
| FBM Quality | | | Dep Ovr Comment | | |
| Foundation | 05 | Conc Block | Misc Imp Ovr | | |
| Bsmt Garage | 0 | | Misc Imp Ovr Comment | | |
| Bsmt Area | 2146 | | Cost to Cure Ovr | | |
| | | | Cost to Cure Ovr Comment | | |

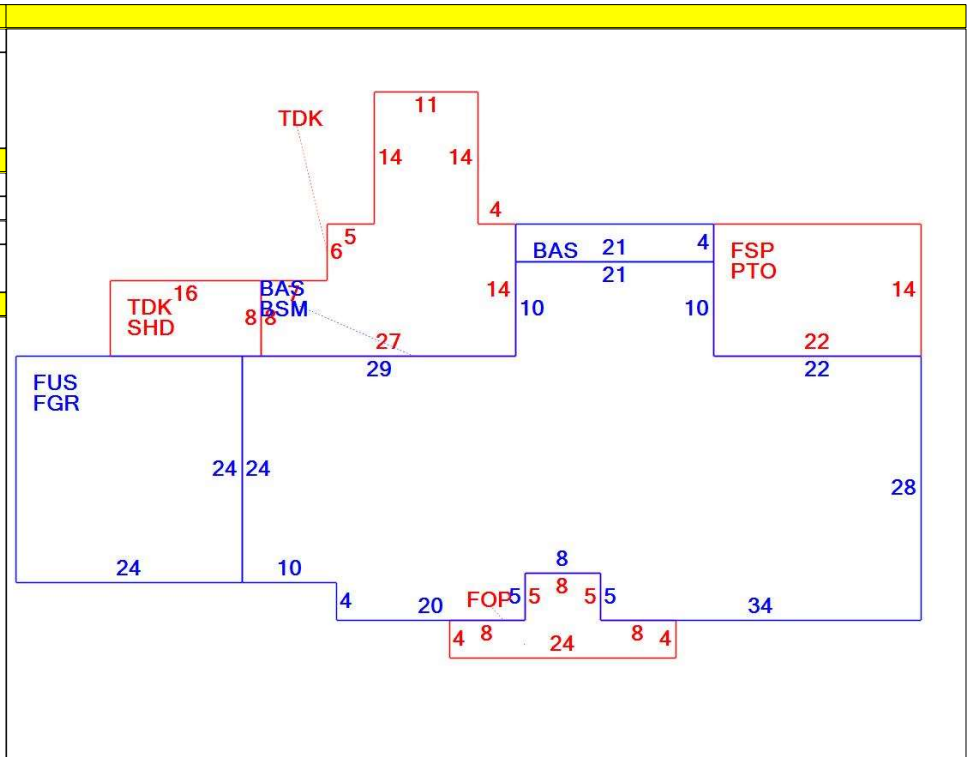

| OB - OUTBUILDING & YARD ITEMS(L) / XF - BUILDING EXTRA FEATURES(B) | | | | | | | | | | |
|--|-------------|-----|-------|------------|--------|----------|------|-------|------------|-------------|
| Code | Description | L/B | Units | Unit Price | Yr Blt | Cond. Cd | % Gd | Grade | Grade Adj. | Appr. Value |
| | | | | | | | | | | |

| BUILDING SUB-AREA SUMMARY SECTION | | | | | | |
|-----------------------------------|----------------------|-------------|------------|----------|-----------|----------------|
| Code | Description | Living Area | Floor Area | Eff Area | Unit Cost | Undeprec Value |
| BAS | First Floor | 2,230 | 2,230 | 2,230 | 207.18 | 462,017 |
| BSM | Basement | 0 | 2,146 | 429 | 41.42 | 88,881 |
| FGR | Garage | 0 | 576 | 230 | 82.73 | 47,652 |
| FOP | Open Porch | 0 | 136 | 20 | 30.47 | 4,144 |
| FSP | Screened Porch | 0 | 308 | 62 | 41.71 | 12,845 |
| FUS | Finished Upper Story | 576 | 576 | 576 | 207.18 | 119,337 |
| PTO | Patio | 0 | 308 | 15 | 10.09 | 3,108 |
| SHD | Attached Shed | 0 | 128 | 45 | 72.84 | 9,323 |
| TDK | Trex Deck | 0 | 618 | 62 | 20.79 | 12,845 |
| Ttl Gross Liv / Lease Area | | 2,806 | 7,026 | 3,669 | | 760,152 |

