

CONSTRUCTION DETAIL			CONSTRUCTION DETAIL (CONTINUED)		
Element	Cd	Description	Element	Cd	Description
Style	04	Cape Cod	Bsmt Area	1391	
Model	01	Residential	Bsmt Type	04	
Grade	06	Good	Unfin Area	0.00	Full
Stories	1.75				
Occupancy	1				
Exterior Wall 1	14	Wood Shingle			
Exterior Wall 2					
Roof Structure	03	Gable			
Roof Cover	03	Asphalt			
Interior Wall 1	05	Drywall			
Interior Wall 2					
Interior Floor 1	12	Hardwood			
Interior Floor 2					
Heat Fuel	03	Gas			
Heat Type	05	Hot Water			
AC Type	01	None			
Bedrooms	4				
Full Baths	3				
Half Baths	0				
Extra Fixtures	2				
Total Rooms	8				
Bath Style	02	Average			
Kitchen Style	02	Average			
Extra Kitchens	0				
Fireplaces	1				
Extra Openings	1				
Gas Fireplaces	0				
Sq Ft Fin Bsmt	0				
FBM Quality					
Foundation	06	Poured Conc			
Bsmt Garage	0				
Bsmt Area	1391				

CONDO DATA				
Parcel Id		C	Own	
			B	S
Adjust Type	Code	Description	Factor%	
Condo Flr				
Condo Unit				

COST / MARKET VALUATION	
Net Other Adj	771,567
Replace Cost	26,825
Year Built	798,393
Effective Year Built	1966
Depreciation Code	1997
Remodel Rating	G
Year Remodeled	
Depreciation %	24
Functional Obsol	
External Obsol	
Trend Factor	1.000
Condition	
Condition %	
Percent Good	76
Cns Sect Rcnd	606,800
Dep % Ovr	
Dep Ovr Comment	
Misc Imp Ovr	
Misc Imp Ovr Comment	
Cost to Cure Ovr	
Cost to Cure Ovr Comment	

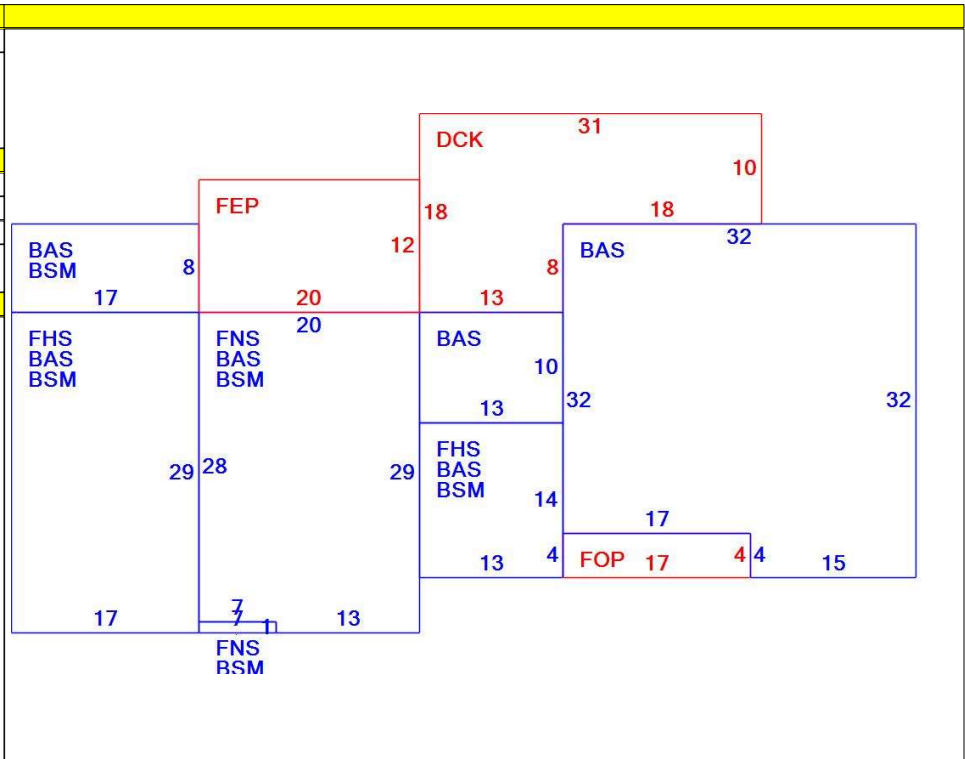

OB - OUTBUILDING & YARD ITEMS(L) / XF - BUILDING EXTRA FEATURES(B)										
Code	Description	L/B	Units	Unit Price	Yr Blt	Cond. Cd	% Gd	Grade	Grade Adj.	Appr. Value
FGR1	Garage - 1 Sto	L	576	52.00	1985	A	70	C	1.00	21,000

BUILDING SUB-AREA SUMMARY SECTION						
Code	Description	Living Area	Floor Area	Eff Area	Unit Cost	Undeprec Value
BAS	First Floor	2,470	2,470	2,470	202.88	501,123
BSM	Basement	0	1,391	278	40.55	56,402
DCK	Deck	0	414	41	20.09	8,318
FEP	Finished Enclosed Porch	0	240	144	121.73	29,215
FHS	Finished Half Story	338	675	338	101.59	68,575
FNS	Finished 90% Story	522	580	522	182.60	105,905
FOP	Open Porch	0	68	10	29.84	2,029
Ttl Gross Liv / Lease Area		3,330	5,838	3,803		771,567

