

| CURRENT OWNER | | TOPO | UTILITIES | STRT / ROAD | LOCATION | CURRENT ASSESSMENT | | | | | |
|-------------------------------------------------|--|-------------------|-----------|--------------------|----------|--------------------|---------|-------------|--------|--------------------|-----------|
| Dwyer John J PO BOX 2749 Duxbury MA 02331 | | 0 | Water | 0 | Dead End | 0 | Average | Description | Code | Appraised | Assessed |
| | | 0 | No Sewer | 0 | Paved | 0 | Average | RESIDNTL | 1010 | 1,056,900 | 1,056,900 |
| | | 0 | Light | | | | | RES LAND | 1010 | 1,017,200 | 1,017,200 |
| SUPPLEMENTAL DATA | | | | | | RESIDNTL | 1010 | 31,000 | 31,000 | 905 DUXBURY, MA | |
| Alt Prcl ID | | Scnd Home | | Cyclical Exemption | | 9 | | | | | |
| Tax Class T | | Tot Fin Area 3338 | | District W | | Res Exem | | | | | |
| Total Acres .22 | | Chapter Lan | | Assoc Pid# | | | | | | | |
| GIS ID F_881987_2829911 | | | | | | | | Total | | 2,105,100 | 2,105,100 |

VISION

| RECORD OF OWNERSHIP | | BK-VOL/PAGE | SALE DATE | Q/U | V/I | SALE PRICE | VC | PREVIOUS ASSESSMENTS (HISTORY) | | | | | | | | |
|------------------------------|--|-------------|------------|-----|-----|------------|----|--------------------------------|------|-----------|-------|------|-----------|-------|------|-----------|
| Dwyer Susan H & Timothy J TT | | 58275 192 | 09-14-2023 | U | I | 1 | 1A | Year | Code | Assessed | Year | Code | Assessed | Year | Code | Assessed |
| Dwyer Susan H & Timothy J TT | | 58271 5 | 09-13-2023 | U | I | 1 | 1A | 2023 | 1010 | 798,300 | 2022 | 1010 | 733,800 | 2021 | 1010 | 635,400 |
| Dwyer John J | | 34768 0272 | 07-03-2007 | U | I | 100 | 1A | | 1010 | 1,148,700 | | 1010 | 1,035,200 | | 1010 | 1,041,400 |
| Dwyer John J | | 28765 0190 | 07-30-2004 | U | I | 700,000 | 1 | | 1010 | 8,100 | | 1010 | 8,100 | | 1010 | 8,100 |
| Bohem Deborah L | | 12685 0155 | 02-24-1994 | U | I | 1 | 1F | Total | | 1,955,100 | Total | | 1,777,100 | Total | | 1,684,900 |

| EXEMPTIONS | | | OTHER ASSESSMENTS | | | | | |
|------------|------|-------------|-------------------|------|-------------|--------|--------|----------|
| Year | Code | Description | Amount | Code | Description | Number | Amount | Comm Int |
| Total | | | 0.00 | | | | | |

This signature acknowledges a visit by a Data Collector or Assessor

| APPRAISED VALUE SUMMARY | | | |
|-------------------------------|-----------|--|--|
| Appraised Bldg. Value (Card) | 1,056,900 | | |
| Appraised Xf (B) Value (Bldg) | 0 | | |
| Appraised Ob (B) Value (Bldg) | 31,000 | | |
| Appraised Land Value (Bldg) | 1,017,200 | | |
| Special Land Value | 0 | | |
| Total Appraised Parcel Value | 2,105,100 | | |
| Valuation Method | C | | |
| Total Appraised Parcel Value | 2,105,100 | | |

| ASSESSING NEIGHBORHOOD | | | | |
|------------------------|-----------|---|---------|-------|
| Nbhd | Nbhd Name | B | Tracing | Batch |
| 0100 | | | | |

| NOTES | | | | | | | | | |
|-------|--|--|--|--|--|--|--|--|--|
| | | | | | | | | | |

| BUILDING PERMIT RECORD | | | | | | | | | | VISIT / CHANGE HISTORY | | | | | |
|------------------------|------------|------|---------------|---------|------------|--------|-----------|---------------------|--|------------------------|-----|------|----|----|------------------|
| Permit Id | Issue Date | Type | Description | Amount | Insp Date | % Comp | Date Comp | Comments | | Date | Id | Type | Is | Cd | Purpose/Result |
| 345 | 10-31-2007 | NC | New Construct | 336,000 | | 100 | | SN FAM 3204'LV G576 | | 12-06-2022 | SJT | 10 | | 00 | Measure & Listed |
| 337 | 10-26-2007 | DM | Demolish | 11,000 | | 100 | | GARAGE & DWELLING | | 04-12-2013 | VGS | | | 20 | Field Review |
| 112397 | 06-24-1993 | AD | Addition | 19,000 | 01-01-1993 | 100 | | TWO SMALL ROOMS | | 09-26-2009 | KP | | 6 | 00 | Measure & Listed |

| LAND LINE VALUATION SECTION | | | | | | | | | | | | | | | | |
|-----------------------------|----------|---------------|------|-----------|------------|------------|------------------------|------------|-------|-------|-----------|-------|---------------------|--------|------------|------------|
| B | Use Code | Description | Zone | Land Type | Land Units | Unit Price | Size Adj | Site Index | Cond. | Nbhd. | Nbhd. Adj | Notes | Location Adjustment | | Adj Unit P | Land Value |
| 1 | 1010 | Single Family | RC | Primary | 9,597 SF | 27.38 | 1.00000 | 5 | 1.00 | 0100 | 3.519 | | V110 | 1.1000 | 105.99 | 1,017,200 |
| Total Card Land Units | | | | | 0.22 | AC | Parcel Total Land Area | | | | | 0.22 | Total Land Value | | | 1,017,200 |

| CONSTRUCTION DETAIL | | | CONSTRUCTION DETAIL (CONTINUED) | | |
|---------------------|------|----------------|---------------------------------|------|-------------|
| Element | Cd | Description | Element | Cd | Description |
| Style | 03 | Colonial | Bsmt Area | 1381 | |
| Model | 01 | Residential | Bsmt Type | 04 | |
| Grade | 09 | Custom | Unfin Area | 0.00 | Full |
| Stories | 2 | | | | |
| Occupancy | 1 | | | | |
| Exterior Wall 1 | 14 | Wood Shingle | | | |
| Exterior Wall 2 | | | | | |
| Roof Structure | 03 | Gable | | | |
| Roof Cover | 10 | Wood Shingle | | | |
| Interior Wall 1 | 05 | Drywall | | | |
| Interior Wall 2 | | | | | |
| Interior Floor 1 | 12 | Hardwood | | | |
| Interior Floor 2 | | | | | |
| Heat Fuel | 03 | Gas | | | |
| Heat Type | 04 | Forced Air-Duc | | | |
| AC Type | 03 | Central | | | |
| Bedrooms | 4 | | | | |
| Full Baths | 5 | | | | |
| Half Baths | 0 | | | | |
| Extra Fixtures | 3 | | | | |
| Total Rooms | 9 | | | | |
| Bath Style | 03 | Modern | | | |
| Kitchen Style | 03 | Modern | | | |
| Extra Kitchens | 0 | | | | |
| Fireplaces | 1 | | | | |
| Extra Openings | 2 | | | | |
| Gas Fireplaces | 0 | | | | |
| Sq Ft Fin Bsmt | 950 | | | | |
| FBM Quality | | | | | |
| Foundation | 06 | Poured Conc | | | |
| Bsmt Garage | 0 | | | | |
| Bsmt Area | 1381 | | | | |

| CONDO DATA | | | |
|-------------|------|-------------|---------|
| Parcel Id | C | Own | S |
| | | | |
| Adjust Type | Code | Description | Factor% |
| Condo Flr | | | |
| Condo Unit | | | |

| COST / MARKET VALUATION | |
|--------------------------|-----------|
| Net Other Adj | 1,041,545 |
| Replace Cost | 94,905 |
| Year Built | 1,136,450 |
| Effective Year Built | 2008 |
| Depreciation Code | 2014 |
| Remodel Rating | E |
| Year Remodeled | |
| Depreciation % | 7 |
| Functional Obsol | |
| External Obsol | |
| Trend Factor | 1.000 |
| Condition | |
| Condition % | |
| Percent Good | 93 |
| Cns Sect Rcnd | 1,056,900 |
| Dep % Ovr | |
| Dep Ovr Comment | |
| Misc Imp Ovr | |
| Misc Imp Ovr Comment | |
| Cost to Cure Ovr | |
| Cost to Cure Ovr Comment | |

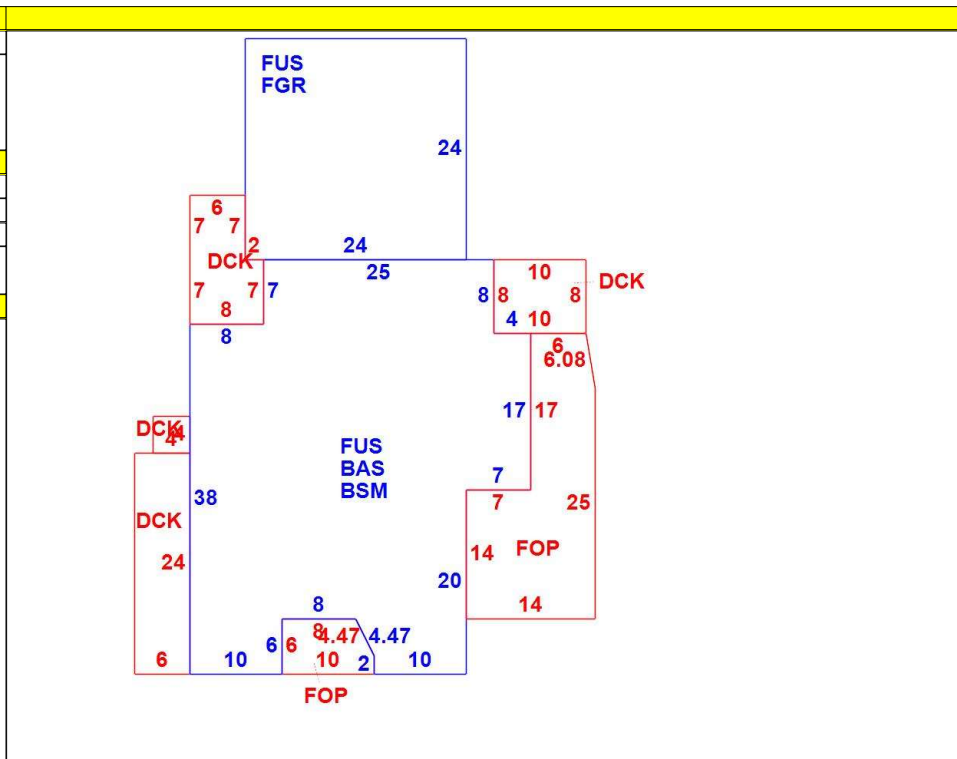

| OB - OUTBUILDING & YARD ITEMS(L) / XF - BUILDING EXTRA FEATURES(B) | | | | | | | | | | |
|--------------------------------------------------------------------|----------------|-----|-------|------------|--------|----------|------|-------|------------|-------------|
| Code | Description | L/B | Units | Unit Price | Yr Blt | Cond. Cd | % Gd | Grade | Grade Adj. | Appr. Value |
| FGR1 | Garage - 1 Sto | L | 288 | 52.00 | 1980 | A | 70 | C | 1.00 | 10,500 |
| GNC | GENERATOR | L | 1 | 24100.00 | 2022 | G | 85 | C | 1.00 | 20,500 |

| BUILDING SUB-AREA SUMMARY SECTION | | | | | | |
|-----------------------------------|----------------------|-------------|------------|----------|-----------|----------------|
| Code | Description | Living Area | Floor Area | Eff Area | Unit Cost | Undeprec Value |
| BAS | First Floor | 1,381 | 1,381 | 1,381 | 264.82 | 365,719 |
| BSM | Basement | 0 | 1,381 | 276 | 52.93 | 73,091 |
| DCK | Deck | 0 | 338 | 34 | 26.64 | 9,004 |
| FGR | Garage | 0 | 576 | 230 | 105.74 | 60,909 |
| FOP | Open Porch | 0 | 368 | 55 | 39.58 | 14,565 |
| FUS | Finished Upper Story | 1,957 | 1,957 | 1,957 | 264.82 | 518,257 |
| Ttl Gross Liv / Lease Area | | 3,338 | 6,001 | 3,933 | | 1,041,545 |

