

| CURRENT OWNER  |  | TOPO   | UTILITIES | STRT / ROAD | LOCATION | CURRENT ASSESSMENT |         |             |          |           |          |   |
|--|--|--|-----------|-------------|----------|--------------------|---------|-------------|----------|-----------|----------|---|
| KENDALL NORMAN P & WALKER EV<br>WALKER KENDALL TRUST<br>324 KEENE ST<br><br>DUXBURY MA 02332                               |  | 0  | Water     | 0           | Feeder   | 0                  | Average | Description | Code     | Appraised | Assessed | 905<br><br>DUXBURY, MA<br><br><b>VISION</b> |
|  |  | 0  | No Sewer  | 0           | Paved    | 0                  | Average | RESIDNTL    | 1010     | 590,600   | 590,600  |   |
|  |  | SUPPLEMENTAL DATA  |           | RES LAND    |          | 1010               | 332,300 | 332,300     | RESIDNTL | 1010      | 1,100    |   |
| Alt Prcl ID<br>Scnd Home<br>Tax Class T<br>Tot Fin Area 3295<br>Total Acres .700<br>Chapter Lan<br>GIS ID F_857731_2849306 |  | Cyclical Exemption W<br>District HISTORIC ATM 2022<br>Res Exem<br>Assoc Pid# |           | 1           |          | Total              |         | 924,000     |          | 924,000   |          |   |

| RECORD OF OWNERSHIP             |     | BK-VOL/PAGE | SALE DATE  | Q/U | V/I | SALE PRICE | VC | PREVIOUS ASSESSMENTS (HISTORY) |      |          |       |      |          |       |      |          |
|---------------------------------|-----|-------------|------------|-----|-----|------------|----|--------------------------------|------|----------|-------|------|----------|-------|------|----------|
| KENDALL NORMAN P & WALKER EVELY | LCC | 121655      | 03-27-2015 | U   | I   | 1          | 1A | Year                           | Code | Assessed | Year  | Code | Assessed | Year  | Code | Assessed |
| WALKER EVELYN A                 | LCC | 97246       | 04-18-2000 | U   | I   | 1          | 1F | 2023                           | 1010 | 564,600  | 2022  | 1010 | 508,000  | 2021  | 1010 | 479,900  |
| KEENE STREET REALTY TRUST       | LCC | 95577       | 06-09-1999 | U   | I   | 100        | 1A |                                | 1010 | 331,900  |       | 1010 | 275,500  |       | 1010 | 223,100  |
| PYE GEORGIA TAFT                | LCC | 95576       | 06-09-1999 | U   | I   | 1          | 1A |                                | 1010 | 700      |       | 1010 | 700      |       | 1010 | 700      |
| KEENE ST RLTY TRUST             | LCC | 91518       | 06-06-1997 | U   | I   | 100        | 1A | Total                          |      | 897,200  | Total |      | 784,200  | Total |      | 703,700  |

| EXEMPTIONS |      |             | OTHER ASSESSMENTS |      |             |        |        |          |
|------------|------|-------------|-------------------|------|-------------|--------|--------|----------|
| Year       | Code | Description | Amount            | Code | Description | Number | Amount | Comm Int |
| Total      |      | 0.00        |                   |      |             |        |        |          |

| ASSESSING NEIGHBORHOOD |           |   |         |       |
|------------------------|-----------|---|---------|-------|
| Nbhd                   | Nbhd Name | B | Tracing | Batch |
| 0050                   |           |   |         |       |

| APPRAISED VALUE SUMMARY       |  |  |  |  |  |  |  |  |  |         |  |
|-------------------------------|--|--|--|--|--|--|--|--|--|---------|--|
| Appraised Bldg. Value (Card)  |  |  |  |  |  |  |  |  |  | 590,600 |  |
| Appraised Xf (B) Value (Bldg) |  |  |  |  |  |  |  |  |  | 0       |  |
| Appraised Ob (B) Value (Bldg) |  |  |  |  |  |  |  |  |  | 1,100   |  |
| Appraised Land Value (Bldg)   |  |  |  |  |  |  |  |  |  | 332,300 |  |
| Special Land Value            |  |  |  |  |  |  |  |  |  | 0       |  |
| Total Appraised Parcel Value  |  |  |  |  |  |  |  |  |  | 924,000 |  |
| Valuation Method              |  |  |  |  |  |  |  |  |  | C       |  |
| Total Appraised Parcel Value  |  |  |  |  |  |  |  |  |  | 924,000 |  |

| BUILDING PERMIT RECORD |            |      |               |         |            |        |            | VISIT / CHANGE HISTORY          |            |     |      |    |    |                    |
|------------------------|------------|------|---------------|---------|------------|--------|------------|---------------------------------|------------|-----|------|----|----|--------------------|
| Permit Id              | Issue Date | Type | Description   | Amount  | Insp Date  | % Comp | Date Comp  | Comments                        | Date       | Id  | Type | Is | Cd | Purpose/Result     |
| QPO-21-21              | 09-09-2021 | MN   | Maintenance   | 4,000   |            | 100    | 10-18-2021 | Weatherization and air sealing. | 10-17-2022 | SJT | 10   |    | 01 | Measure - No Entry |
| 2018-36                | 03-19-2018 | MN   | Maintenance   | 10,000  | 06-30-2018 | 100    |            | STRIP & REROOF                  | 04-12-2013 | VGS |      |    | 20 | Field Review       |
| 216                    | 11-12-2009 | NC   | New Construct | 125,000 |            | 100    |            | 30X22 AD&6X16 1STYA             | 10-11-2012 | KP  | 6    |    | 30 | Quality Control    |
| 19                     | 03-23-2009 | MN   | Maintenance   | 2,500   |            | 100    |            | WOOD SIDING                     | 06-15-2010 | KP  |      | 1  | 00 | Measure & Listed   |

| LAND LINE VALUATION SECTION |          |               |      |           |            |            |                        |            |       |       |           |       |                     |            |            |         |
|-----------------------------|----------|---------------|------|-----------|------------|------------|------------------------|------------|-------|-------|-----------|-------|---------------------|------------|------------|---------|
| B                           | Use Code | Description   | Zone | Land Type | Land Units | Unit Price | Size Adj               | Site Index | Cond. | Nbhd. | Nbhd. Adj | Notes | Location Adjustment | Adj Unit P | Land Value |         |
| 1                           | 1010     | Single Family | RC   | Primary   | 30,500     | SF         | 10.90                  | 1.00000    | 5     | 1.00  | 0050      | 1.000 |                     | 1.0000     | 10.90      | 332,300 |
| Total Card Land Units       |          |               |      |           | 0.70       | AC         | Parcel Total Land Area |            |       |       |           | 0.70  | Total Land Value    |            |            | 332,300 |

| CONSTRUCTION DETAIL |      |              | CONSTRUCTION DETAIL (CONTINUED) |      |             |
|---------------------|------|--------------|---------------------------------|------|-------------|
| Element             | Cd   | Description  | Element                         | Cd   | Description |
| Style               | 11   | Antique      | Bsmt Area                       | 382  |             |
| Model               | 01   | Residential  | Bsmt Type                       | 02   |             |
| Grade               | 06   | Good         | Unfin Area                      | 0.00 | Crawl       |
| Stories             | 1.75 |              |                                 |      |             |
| Occupancy           | 1    |              |                                 |      |             |
| Exterior Wall 1     | 14   | Wood Shingle |                                 |      |             |
| Exterior Wall 2     |      |              |                                 |      |             |
| Roof Structure      | 03   | Gable        |                                 |      |             |
| Roof Cover          | 10   | Wood Shingle |                                 |      |             |
| Interior Wall 1     | 05   | Drywall      |                                 |      |             |
| Interior Wall 2     |      |              |                                 |      |             |
| Interior Floor 1    | 12   | Hardwood     |                                 |      |             |
| Interior Floor 2    |      |              |                                 |      |             |
| Heat Fuel           | 03   | Gas          |                                 |      |             |
| Heat Type           | 05   | Hot Water    |                                 |      |             |
| AC Type             | 03   | Central      |                                 |      |             |
| Bedrooms            | 3    |              |                                 |      |             |
| Full Baths          | 2    |              |                                 |      |             |
| Half Baths          | 1    |              |                                 |      |             |
| Extra Fixtures      | 1    |              |                                 |      |             |
| Total Rooms         | 9    |              |                                 |      |             |
| Bath Style          | 02   | Average      |                                 |      |             |
| Kitchen Style       | 02   | Average      |                                 |      |             |
| Extra Kitchens      | 0    |              |                                 |      |             |
| Fireplaces          | 2    |              |                                 |      |             |
| Extra Openings      | 0    |              |                                 |      |             |
| Gas Fireplaces      | 0    |              |                                 |      |             |
| Sq Ft Fin Bsmt      | 0    |              |                                 |      |             |
| FBM Quality         |      |              |                                 |      |             |
| Foundation          | 03   | Stone        |                                 |      |             |
| Bsmt Garage         | 0    |              |                                 |      |             |
| Bsmt Area           | 382  |              |                                 |      |             |

| CONDO DATA  |      |             |         |   |
|-------------|------|-------------|---------|---|
| Parcel Id   |      | C           | Own     |   |
|             |      |             | B       | S |
| Adjust Type | Code | Description | Factor% |   |
| Condo Flr   |      |             |         |   |
| Condo Unit  |      |             |         |   |

| COST / MARKET VALUATION  |         |
|--------------------------|---------|
| Net Other Adj            | 692,275 |
| Replace Cost             | 27,985  |
| Year Built               | 1780    |
| Effective Year Built     | 2003    |
| Depreciation Code        | E       |
| Remodel Rating           |         |
| Year Remodeled           |         |
| Depreciation %           | 18      |
| Functional Obsol         |         |
| External Obsol           |         |
| Trend Factor             | 1.000   |
| Condition                |         |
| Condition %              |         |
| Percent Good             | 82      |
| Cns Sect Rcnld           | 590,600 |
| Dep % Ovr                |         |
| Dep Ovr Comment          |         |
| Misc Imp Ovr             |         |
| Misc Imp Ovr Comment     |         |
| Cost to Cure Ovr         |         |
| Cost to Cure Ovr Comment |         |

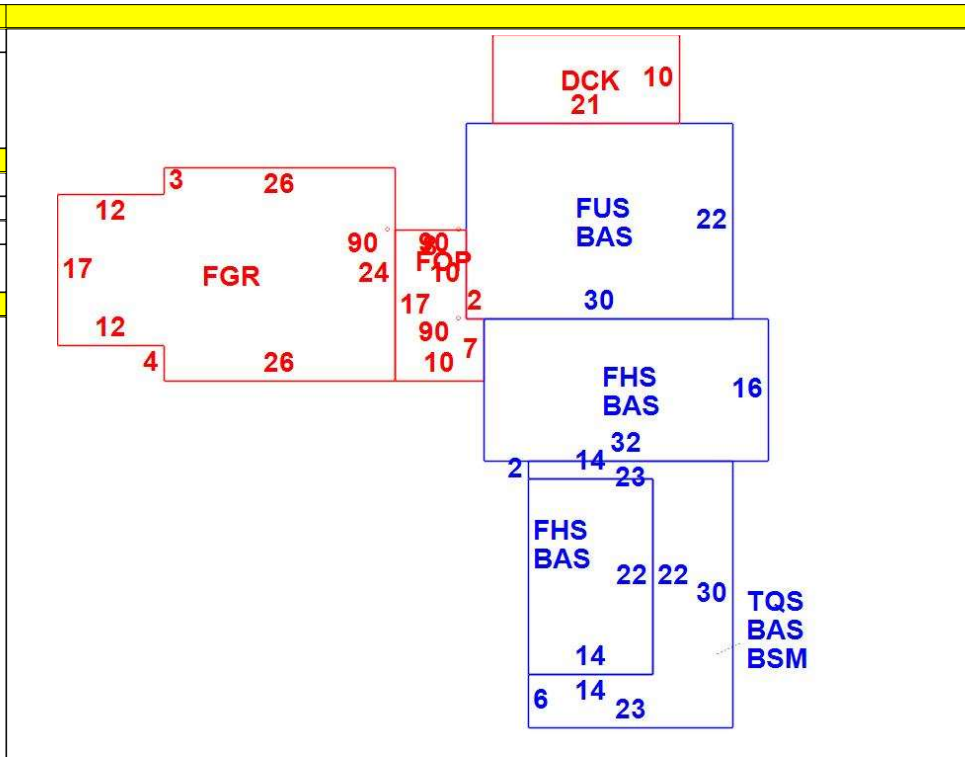

**OB - OUTBUILDING & YARD ITEMS(L) / XF - BUILDING EXTRA FEATURES(B)**

| Code | Description | L/B | Units | Unit Price | Yr Blt | Cond. Cd | % Gd | Grade | Grade Adj. | Appr. Value |
|------|-------------|-----|-------|------------|--------|----------|------|-------|------------|-------------|
| SHD1 | Shed        | L   | 91    | 21.00      | 1980   | F        | 55   | C     | 1.00       | 1,100       |

**BUILDING SUB-AREA SUMMARY SECTION**

| Code                       | Description          | Living Area | Floor Area | Eff Area | Unit Cost | Undeprec Value |
|----------------------------|----------------------|-------------|------------|----------|-----------|----------------|
| BAS                        | First Floor          | 1,862       | 1,862      | 1,862    | 188.63    | 351,230        |
| BSM                        | Basement             | 0           | 382        | 76       | 37.53     | 14,336         |
| DCK                        | Deck                 | 0           | 210        | 21       | 18.86     | 3,961          |
| FGR                        | Garage               | 0           | 828        | 331      | 75.41     | 62,437         |
| FHS                        | Finished Half Story  | 410         | 820        | 410      | 94.32     | 77,339         |
| FOP                        | Open Porch           | 0           | 150        | 23       | 28.92     | 4,339          |
| FUS                        | Finished Upper Story | 660         | 660        | 660      | 188.63    | 124,496        |
| TQS                        | Three Quarter Story  | 287         | 382        | 287      | 141.72    | 54,137         |
| Ttl Gross Liv / Lease Area |                      | 3,219       | 5,294      | 3,670    |           | 692,275        |

