

CURRENT OWNER		TOPO	UTILITIES	STRT / ROAD	LOCATION	CURRENT ASSESSMENT				905 DUXBURY, MA VISION		
WHITNEY CHRISTINE S 916 UNION ST DUXBURY MA 02332		0	Water	0	Feeder	0	Average	Description	Code		Appraised	Assessed
		0	Septic	0	Paved	0	Average	RESIDNTL	1010		235,100	235,100
				0	Medium			RES LAND	1010		407,300	407,300
SUPPLEMENTAL DATA						RESIDNTL	1010	1,200	1,200			
Alt Prcl ID Scnd Home Tax Class T Tot Fin Area 2904 Total Acres 7.198 Chapter Lan GIS ID F_856880_2852571				Cyclical 1 Exemption W District Res Exem Assoc Pid#		Total		643,600	643,600			

RECORD OF OWNERSHIP		BK-VOL/PAGE	SALE DATE	Q/U	V/I	SALE PRICE	VC	PREVIOUS ASSESSMENTS (HISTORY)								
WHITNEY CHRISTINE S		14901 0003	01-09-1997	U	I	215,000	1	Year	Code	Assessed	Year	Code	Assessed	Year	Code	Assessed
STRAUSS PHILIP W		12335 0141	10-28-1993	Q	I	200,000	00	2023	1010	251,300	2022	1010	222,100	2021	1010	209,000
									1010	445,600		1010	372,000		1010	311,000
									1010	900		1010	900		1010	900
								Total		697,800	Total		595,000	Total		520,900

EXEMPTIONS			OTHER ASSESSMENTS					This signature acknowledges a visit by a Data Collector or Assessor					
Year	Code	Description	Amount	Code	Description	Number	Amount	Comm Int					
Total			0.00										

ASSESSING NEIGHBORHOOD					APPRAISED VALUE SUMMARY					
Nbhd	Nbhd Name	B	Tracing	Batch	Appraised Bldg. Value (Card)					235,100
0050					Appraised Xf (B) Value (Bldg)					0
					Appraised Ob (B) Value (Bldg)					1,200
					Appraised Land Value (Bldg)					407,300
					Special Land Value					0
					Total Appraised Parcel Value					643,600
					Valuation Method					C
					Total Appraised Parcel Value					643,600

BUILDING PERMIT RECORD										VISIT / CHANGE HISTORY					
Permit Id	Issue Date	Type	Description	Amount	Insp Date	% Comp	Date Comp	Comments		Date	Id	Type	Is	Cd	Purpose/Result
										04-12-2013	VGS			20	Field Review
										10-31-2007	BSB		1	00	Measure & Listed

LAND LINE VALUATION SECTION																
B	Use Code	Description	Zone	Land Type	Land Units	Unit Price	Size Adj	Site Index	Cond.	Nbhd.	Nbhd. Adj	Notes	Location Adjustment	Adj Unit P	Land Value	
1	1010	Single Family	PD	Primary	40,000	SF 8.75	1.00000	5	1.00	0050	1.000	POOR SHAPE		1.0000	8.75	350,000
1	1010	Single Family	PD	Residual	3.280	AC 35,000.00	0.44721	5	1.00	0050	1.000			1.0000	0.36	51,300
1	1010	Single Family	RC	Undevelop	3.000	AC 2,000.00	1.00000	0	1.00	0050	1.000	WETLANDS		1.0000	0.05	6,000
Total Card Land Units					7.20	AC	Parcel Total Land Area					7.20	Total Land Value			407,300

CONSTRUCTION DETAIL			CONSTRUCTION DETAIL (CONTINUED)		
Element	Cd	Description	Element	Cd	Description
Style	01	Ranch	Bsmt Area	2904	
Model	01	Residential	Bsmt Type	00	N/A
Grade	02	Below Average	Unfin Area	0.00	
Stories	1				
Occupancy	1		CONDO DATA		
Exterior Wall 1	05	Average	Parcel Id		C
Exterior Wall 2					B
Roof Structure	03	Gable	Adjust Type	Code	Description
Roof Cover	03	Asphalt	Condo Flr		Factor%
Interior Wall 1	05	Drywall	Condo Unit		
Interior Wall 2			COST / MARKET VALUATION		
Interior Floor 1	12	Hardwood	Net Other Adj		353,571
Interior Floor 2			Replace Cost		58,820
Heat Fuel	02	Oil	Year Built		412,390
Heat Type	05	Hot Water	Effective Year Built		1981
AC Type	01	None	Depreciation Code		1988
Bedrooms	4		Remodel Rating		F
Full Baths	2		Year Remodeled		
Half Baths	0		Depreciation %		33
Extra Fixtures	1		Functional Obsol		10
Total Rooms	7		External Obsol		
Bath Style	02	Average	Trend Factor		1.000
Kitchen Style	02	Average	Condition		
Extra Kitchens	0		Condition %		
Fireplaces	2		Percent Good		57
Extra Openings	1		Cns Sect Rcnd		235,100
Gas Fireplaces	0		Dep % Ovr		
Sq Ft Fin Bsmt	2060		Dep Ovr Comment		
FBM Quality	02	Low Quality	Misc Imp Ovr		
Foundation	06	Poured Conc	Misc Imp Ovr Comment		
Bsmt Garage	0		Cost to Cure Ovr		
Bsmt Area	2904		Cost to Cure Ovr Comment		

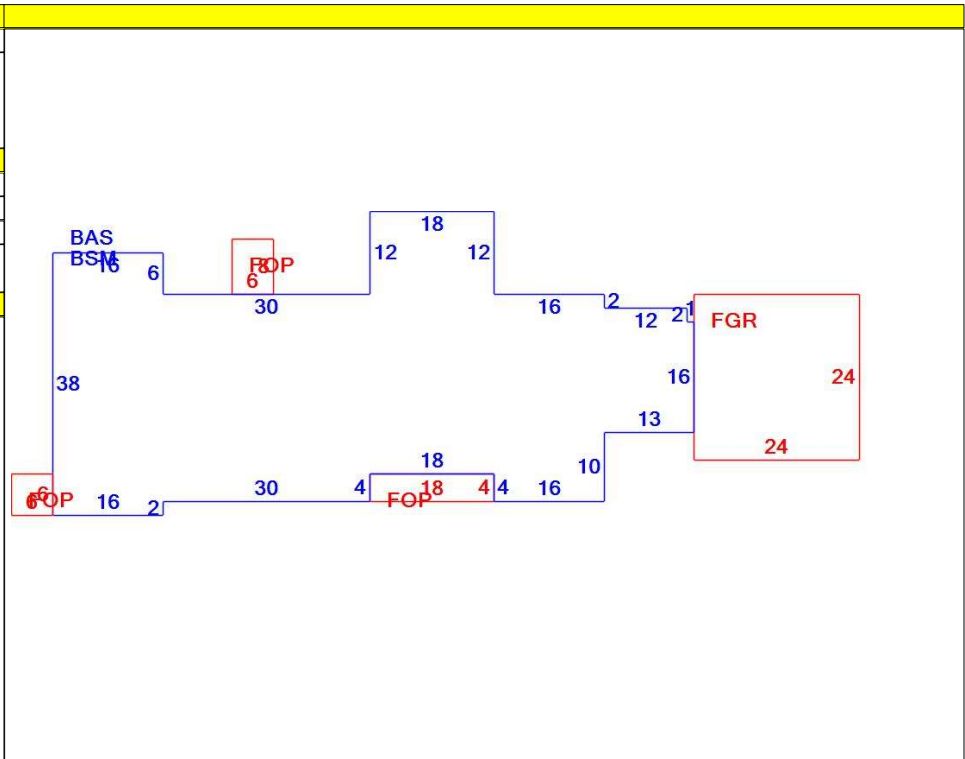

OB - OUTBUILDING & YARD ITEMS(L) / XF - BUILDING EXTRA FEATURES(B)										
Code	Description	L/B	Units	Unit Price	Yr Blt	Cond. Cd	% Gd	Grade	Grade Adj.	Appr. Value
SHD1	Shed	L	36	21.00	1985	A	70	C	1.00	500
SHD1	Shed	L	48	21.00	1985	A	70	C	1.00	700

BUILDING SUB-AREA SUMMARY SECTION						
Code	Description	Living Area	Floor Area	Eff Area	Unit Cost	Undeprec Value
BAS	First Floor	2,904	2,904	2,904	94.59	274,684
BSM	Basement	0	2,904	581	18.92	54,956
FGR	Garage	0	576	230	37.77	21,755
FOP	Open Porch	0	156	23	13.95	2,176
Ttl Gross Liv / Lease Area		2,904	6,540	3,738		353,571

