

CURRENT OWNER		TOPO	UTILITIES	STRT / ROAD	LOCATION	CURRENT ASSESSMENT				
DUFFY MICHAEL			0 Water	0 Cul-De-Sac	0 Average	Description	Code	Appraised	Assessed	905  DUXBURY, MA
FLAHERTY MEGAN			0 No Sewer	0 Paved	0 Average	RESIDNTL	1010	386,800	386,800	
10 KEENES BROOK LN				0 Light		RES LAND	1010	427,600	427,600	
<b>SUPPLEMENTAL DATA</b>										
DUXBURY MA 02332		Alt Prcl ID	Cyclical 1							
		Scnd Home	Exemption							
		Tax Class T	W							
		Tot Fin Area 2076	District							
		Total Acres .545	Res Exem							
		Chapter Lan								
		GIS ID F_858670_2850710	Assoc Pid#							
							Total	824,900	824,900	

**VISION**

RECORD OF OWNERSHIP		BK-VOL/PAGE	SALE DATE	Q/U	V/I	SALE PRICE	VC	PREVIOUS ASSESSMENTS (HISTORY)					
DUFFY MICHAEL		57086 25	07-29-2022	Q	I	875,000	00	Year	Code	Assessed	Year	Code	Assessed
MEAGHER THOMAS F & CLARE T TT		54113 112	12-31-2020	U	I	100	1A	2023	1010	269,500	2022	1010	246,500
MEAGHER THOMAS F & CLARE T TT		5298 0465	02-18-1983	Q	I	96,000	00		1010	458,400		1010	294,000
							Total	727,900	Total	540,500	Total	498,700	

EXEMPTIONS			OTHER ASSESSMENTS					
Year	Code	Description	Amount	Code	Description	Number	Amount	Comm Int
		Total	0.00					

This signature acknowledges a visit by a Data Collector or Assessor

ASSESSING NEIGHBORHOOD				
Nbhd	Nbhd Name	B	Tracing	Batch
0060				

  

APPRAISED VALUE SUMMARY	
Appraised Bldg. Value (Card)	386,800
Appraised Xf (B) Value (Bldg)	0
Appraised Ob (B) Value (Bldg)	10,500
Appraised Land Value (Bldg)	427,600
Special Land Value	0
Total Appraised Parcel Value	824,900
Valuation Method	C
Total Appraised Parcel Value	824,900

BUILDING PERMIT RECORD										VISIT / CHANGE HISTORY					
Permit Id	Issue Date	Type	Description	Amount	Insp Date	% Comp	Date Comp	Comments		Date	Id	Type	Is	Cd	Purpose/Result
20000294	08-15-2000	AD	Addition	5,000	07-30-2001	100		6 X 14 ADDITION		10-18-2022	SJT	10		07	Measure - Info @ Door
										04-12-2013	VGS			20	Field Review
										07-30-2001	KP		1	00	Measure & Listed

LAND LINE VALUATION SECTION															
B	Use Code	Description	Zone	Land Type	Land Units	Unit Price	Size Adj	Site Index	Cond.	Nbhd.	Nbhd. Adj	Notes	Location Adjustment	Adj Unit P	Land Value
1	1010	Single Family	PD	Primary	23,744 SF	13.43	1.00000	5	1.00	0060	1.341		1.0000	18.01	427,600
Total Card Land Units					0.55 AC	Parcel Total Land Area					0.55	Total Land Value			427,600

CONSTRUCTION DETAIL			CONSTRUCTION DETAIL (CONTINUED)		
Element	Cd	Description	Element	Cd	Description
Style	03	Colonial	Bsmt Area	1004	
Model	01	Residential	Bsmt Type	03	
Grade	05	Ave/Good	Unfin Area	0.00	Partial
Stories	2				
Occupancy	1		<b>CONDO DATA</b>		
Exterior Wall 1	14	Wood Shingle	Parcel Id		C
Exterior Wall 2					B
Roof Structure	03	Gable	Adjust Type	Code	Description
Roof Cover	03	Asphalt	Condo Flr		Factor%
Interior Wall 1	05	Drywall	Condo Unit		
Interior Wall 2			<b>COST / MARKET VALUATION</b>		
Interior Floor 1	12	Hardwood	Net Other Adj		466,381
Interior Floor 2			Replace Cost		23,270
Heat Fuel	02	Oil	Year Built		1981
Heat Type	05	Hot Water	Effective Year Built		2000
AC Type	01	None	Depreciation Code		G
Bedrooms	4		Remodel Rating		
Full Baths	2		Year Remodeled		
Half Baths	1		Depreciation %		21
Extra Fixtures	1		Functional Obsol		
Total Rooms	9		External Obsol		
Bath Style	02	Average	Trend Factor		1.000
Kitchen Style	02	Average	Condition		
Extra Kitchens	0		Condition %		
Fireplaces	1		Percent Good		79
Extra Openings	0		Cns Sect Rcnld		386,800
Gas Fireplaces	0		Dep % Ovr		
Sq Ft Fin Bsmt	0		Dep Ovr Comment		
FBM Quality			Misc Imp Ovr		
Foundation	06	Poured Conc	Misc Imp Ovr Comment		
Bsmt Garage	2		Cost to Cure Ovr		
Bsmt Area	1004		Cost to Cure Ovr Comment		

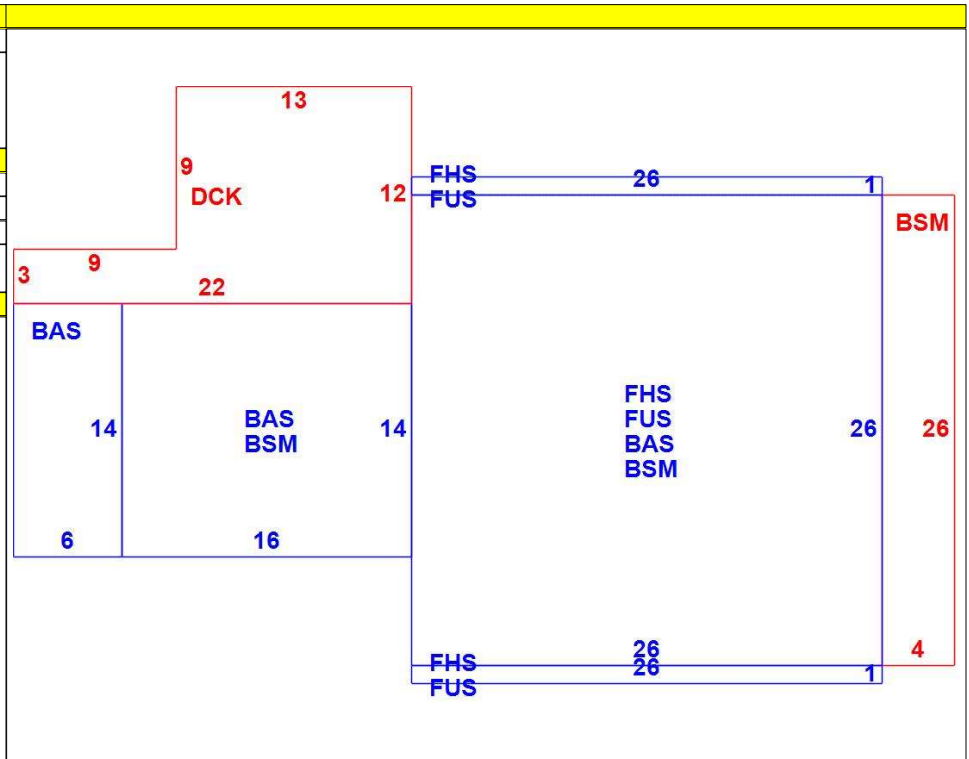

OB - OUTBUILDING & YARD ITEMS(L) / XF - BUILDING EXTRA FEATURES(B)										
Code	Description	L/B	Units	Unit Price	Yr Blt	Cond. Cd	% Gd	Grade	Grade Adj.	Appr. Value
GNR	GENERATOR	L	1	12400.00	2018	G	85	C	1.00	10,500

BUILDING SUB-AREA SUMMARY SECTION						
Code	Description	Living Area	Floor Area	Eff Area	Unit Cost	Undeprec Value
BAS	First Floor	984	984	984	203.22	199,965
BSM	Basement	0	1,004	201	40.68	40,846
DCK	Deck	0	183	18	19.99	3,658
FHS	Finished Half Story	364	728	364	101.61	73,971
FUS	Finished Upper Story	728	728	728	203.22	147,941
Ttl Gross Liv / Lease Area		2,076	3,627	2,295		466,381

