

Key: 1022

Town of E. BRIDGEWATER - Fiscal Year 2023

12/6/2022 6:38 pm SEQ #: 857

LEGAL

CURRENT OWNER				PARCEL ID				LOCATION				
MOUA LEE & YING THAO 741 BEDFORD ST E. BRIDGEWATER, MA 02333				22-40-0				741 BEDFORD ST				
TRANSFER HISTORY				DOS	T	SALE PRICE	BK-PG (Cert)					
MOUA LEE & YING THAO				02/16/2005	QS	463,000	30004-155					
DOUGHTY LOIS E				09/18/1996	QS	185,000	14660-034					
DOUGHTY LOIS E				09/17/1996	QS	185,000	14660-034					
CD	T	AC/SF/UN	Ngh	Inf1	Inf2	ADJ BASE	SAF	Inf3	Lpi	VC	CREDIT AMT	ADJ VALUE
100	S	30,230 7	1.00	100	1.00	178,600	1.35	100	1.00	7	0.95	167,670

LAND

TOTAL	30,230 SF	ZONING	FRNT	0	ASSESSED	CURRENT	PREVIOUS
Ngh	RES 7	NOTE			LAND	167,700	152,500
Inf1	FACTOR 100		BUILDING	295,700	306,900		
Inf2	PHY 100		DETACHED	0	0		
			OTHER	0	0		
					TOTAL	463,400	459,400

DETACHED

TY	QUAL	COND	DIM/NOTE	YB	UNITS	ADJ PRICE	RCNLD	PHOTO	02/27/2020
									

BUILDING

BUILDING	CD	ADJ	DESC	MEASURE	2/28/2020	SB
MODEL	1		RESIDENTIAL	LIST	2/28/2020	SB
STYLE	7	0.90	CONVENTIONAL [100%]	REVIEW		
QUALITY	A	1.00	AVERAGE [100%]			
FRAME	1	1.00	WOOD FRAME [100%]			

YEAR BLT	1800	SIZE ADJ	1.000	ELEMENT	CD	DESCRIPTION	ADJ	S	BAT	T	DESCRIPTION	UNITS	YB	ADJ PRICE	RCN	TOTAL RCN	821,396
NET AREA	5,288	DETAIL ADJ	1.076	FOUNDATION	5	BRICK/STONE	1.00	+	BMU	N	BSMT UNFINISHED	2,608		32.03	83,529		
\$NLA(RCN)	\$155	OVERALL	1.000	EXT COVER	4	VINYL	1.00	+	USF	L	UPPER STORY FIN	2,608	1800	129.11	336,721		
				ROOF SHAPE	1	GABLE	1.00	+	BAS	L	BASE AREA	2,680	1800	142.08	380,771		
				ROOF COVER	1	ASPH SHINGLES	1.00	E	ENT	N	ENCLOSED ENTRY	24		81.08	1,946		
				FLOOR COVER	99	N/A	1.00	F	WDK	N	WOOD DECK	32		31.59	1,011		
				INT FINISH	99	N/A	1.00	+	OPA	N	OPEN PORCH	94		42.70	4,014		
				HEATING/COOLING	11	HW/COOL AIR	1.04		F21	O	FPL 2S 1OP	1		6,819.00	6,819		
				FUEL SOURCE	2	GAS	1.00										
				ARPUD	0		1.00										
				AFFORDABLE	0		1.00										

CLASS	CLASS%	DESCRIPTION			BN ID	BN	CARD	
1050	100	THREE FAMILY				1	1 of 1	
PMT NO	PMT DT	TY	DESC	AMOUNT	INSP	BY	1st	%
2789	12/18/2015	6	CYCL GROWTH		02/28/2020	SLB	100	100
472	07/15/2010	3	ALTERATIONS	32,000			0	0
		3	ALTERATIONS	8,000			0	0
410	05/13/2010	3	ALTERATIONS	15,500			0	0
		6	CYCL GROWTH		05/03/2010	CP	0	0

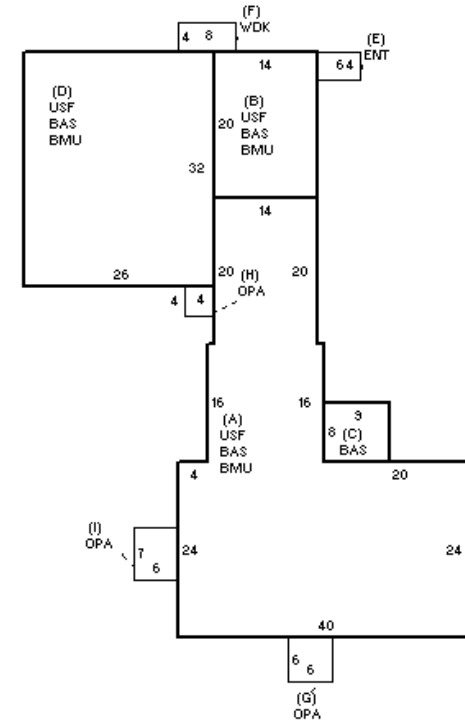

BLDG COMMENTS

CONDITION ELEM	CD
EXTERIOR	
INTERIOR	
KITCHEN	
BATHS	
HEAT	
ELECT	
EFF.YR/AGE 1951 / 70	
COND	64 64 %
FUNC	0
ECON	0
DEPR	64 % GD 36
RCNLD	\$295,700