

Key: 1301

Town of E. BRIDGEWATER - Fiscal Year 2023

12/6/2022 6:38 pm SEQ #: 1.077

LEG  
A  
L  
  
L  
A  
N  
D

CURRENT OWNER				PARCEL ID				LOCATION				
ROSEMARY LAJOIE REVOC. TRUST LAJOIE ROSEMARY TR 320 WHITMAN ST E BRIDGEWATER, MA 02333				31-1-0				320 WHITMAN ST				
TRANSFER HISTORY				DOS	T	SALE PRICE	BK-PG (Cert)					
ROSEMARY LAJOIE REVOC. TR				12/13/2021	A	1	56162-075					
LAJOIE ROSEMARY				09/28/2007	S	229,000	35135-081					
JP MORGAN CHASE BANK				09/25/2007	L	285,328	35110-163					

CLASS	CLASS%	DESCRIPTION		BN ID	BN	CARD	
1010	100	SINGLE FAMILY			1	1 of 1	
PMT NO	PMT DT	TY	DESC	AMOUNT	INSP	BY	1st %
1299		6	CYCL GROWTH		11/02/2017	SD	0 0
146	08/30/2012	6	CYCL GROWTH		05/03/2013		0 0
	10/05/2007	3	ALTERATIONS	3,900			0 100
		3	ALTERATIONS	6,900	05/27/2008		0 100

CD	T	AC/SF/UN	Ngh	Infl1	Infl2	ADJ BASE	SAF	Infl3	Lpi	VC	CREDIT AMT	ADJ VALUE
100	S	43,560	7	1.00	100	178,600	1.00	100	1.00	7	0.95	178,600
300	A	0.870	7	1.00	100	5,700	1.00	100	1.00	ELP	1.00	4,960

TOTAL	1.870 Acres		ZONING	FRNT	0	ASSESSED	CURRENT	PREVIOUS
Ngh	RES 7		NOTE			LAND	183,600	167,000
Infl1	FACTOR 100			BUILDING	179,500	156,900		
Infl2	PHY 100			DETACHED	16,500	15,600		
				OTHER	0	0		
				TOTAL	379,600	339,500		

TY	QUAL	COND	DIM/NOTE	YB	UNITS	ADJ PRICE	RCNLD
DGF	A	1.00	40 0.60		420	55.55	14,000
SHF	A	1.00	40 0.60		200	20.44	2,500

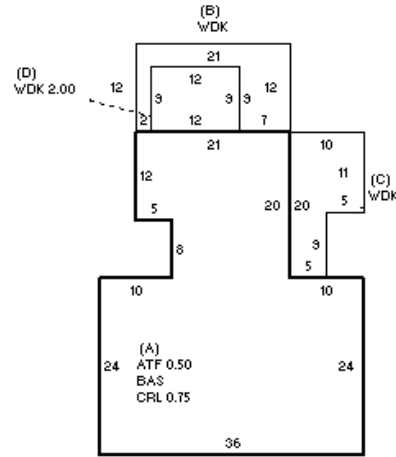

BUILDING	CD	ADJ	DESC	MEASURE	11/2/2017	SD
MODEL	1		RESIDENTIAL	LIST		
STYLE	4	1.00	CAPE [100%]	REVIEW	3/25/2013	ER
QUALITY	A	1.00	AVERAGE [100%]			
FRAME	1	1.00	WOOD FRAME [100%]			

BLDG COMMENTS		
IN-LAW APT		

D  
E  
T  
A  
C  
H  
E  
D

B  
U  
I  
L  
D  
I  
N  
G

YEAR BLT	1790	SIZE ADJ	1.000	ELEMENT	CD	DESCRIPTION	ADJ	S	BAT	T	DESCRIPTION	UNITS	YB	ADJ PRICE	RCN
NET AREA	1,866	DETAIL ADJ	0.988	FOUNDATION	5	BRICK/STONE	1.00	A	CRL	N	BSMT CRAWL	933		8.80	8,211
\$NLA(RCN)	\$178	OVERALL	1.000	EXT COVER	5	ASBESTOS	0.96	A	BAS	L	BASE AREA	1,244	1790	167.64	208,538
				ROOF SHAPE	1	GABLE	1.00	A	ATF	L	ATTIC FINISH	622	1790	108.45	67,457
				ROOF COVER	1	ASPH SHINGLES	1.00	+	WDK	N	WOOD DECK	515		31.60	16,274
				FLOOR COVER	99	N/A	1.00		F21	O	FPL 2S 1OP	3		6,819.33	20,458
				INT FINISH	99	N/A	1.00		KIT	O	XTRA KITCHEN	1		5,387.00	5,387
				HEATING/COOLING	9	WARM/COOL AIR	1.03								
				FUEL SOURCE	2	GAS	1.00								
				ARPUD	0		1.00								
				AFFORDABLE	0		1.00								

TOTAL RCN	332,372	
CONDITION ELEM CD		
EXTERIOR		
INTERIOR		
KITCHEN		
BATHS		
HEAT		
ELECT		
EFF.YR/AGE	1960 / 61	
COND	46	46 %
FUNC	0	
ECON	0	
DEPR	46	% GD 54
RCNLD	\$179,500	