

Key: 1332

Town of E. BRIDGEWATER - Fiscal Year 2023

12/6/2022 6:38 pm SEQ #: 1.095

LEGAL

CURRENT OWNER				PARCEL ID				LOCATION			
PRATT KIMBERLY J 185 WHITMAN ST E BRIDGEWATER, MA 02333				31-20-0				185 WHITMAN ST			
TRANSFER HISTORY				DOS	T	SALE PRICE	BK-PG (Cert)				
PRATT KIMBERLY J				07/22/1999	A	100,000	17689-245				
PRATT KENNETH W & CAROLIN				12/26/1997	A	1	15760-113				
PRATT KENNETH W & CAROLIN				02/17/1966	QS		3274-488				

CLASS	CLASS%	DESCRIPTION			BN ID	BN	CARD	
1010	100	SINGLE FAMILY				1	1 of 1	
PMT NO	PMT DT	TY	DESC	AMOUNT	INSP	BY	1st	%
432	09/15/2008	6	CYCL GROWTH ALTERATIONS	8,846	06/02/2017	SD	0	0
		3			04/23/2009		0	0

LAND

CD	T	AC/SF/UN	Ngh	Inf1	Inf2	ADJ BASE	SAF	Inf3	Lpi	VC	CREDIT AMT	ADJ VALUE
100	S	43,560	7	1.00	100	178,600	1.00	100	1.00	7	0.95	178,600
300	A	0.130	7	1.00	100	5,700	1.00	100	1.00	ELP	1.00	740

TOTAL	1.130 Acres	ZONING	FRNT	0	ASSESSED	CURRENT	PREVIOUS
Ngh	RES 7	NOTE			LAND	179,300	163,100
Inf1	FACTOR 100		BUILDING	134,400	132,900		
Inf2	PHY 100		DETACHED	2,500	2,300		
			OTHER	0	0		
					<b>TOTAL</b>	<b>316,200</b>	<b>298,300</b>

DETACHED

TY	QUAL	COND	DIM/NOTE	YB	UNITS	ADJ PRICE	RCNLD	PHOTO
SHF	A	1.00	40 0.60		200	20.44	2,500	06/08/2017



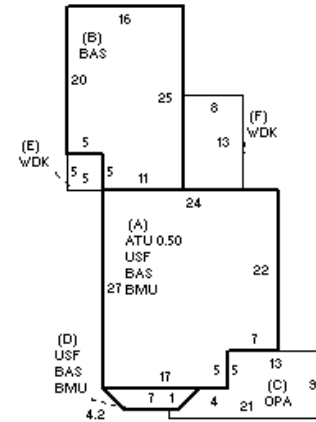

BUILDING

BUILDING	CD	ADJ	DESC	MEASURE	6/2/2017	SD
MODEL	1		RESIDENTIAL	LIST		
STYLE	7	0.90	CONVENTIONAL [100%]	REVIEW	3/26/2013	ER
QUALITY	A	1.00	AVERAGE [100%]			
FRAME	1	1.00	WOOD FRAME [100%]			

YEAR BLT	1900	SIZE ADJ	1.000	ELEMENT	CD	DESCRIPTION	ADJ	S	BAT	T	DESCRIPTION	UNITS	YB	ADJ PRICE	RCN
NET AREA	1,661	DETAIL ADJ	0.900	FOUNDATION	5	BRICK/STONE	1.00	+	BMU	N	BSMT UNFINISHED	643		45.04	28,961
\$NLA(RCN)	\$184	OVERALL	1.000	EXT COVER	4	VINYL	1.00	+	USF	L	UPPER STORY FIN	643	1900	144.75	93,074
				ROOF SHAPE	1	GABLE	1.00	A	ATU	N	ATTIC UNF	307		30.30	9,302
				ROOF COVER	1	ASPH SHINGLES	1.00	+	BAS	L	BASE AREA	1,018	1900	159.29	162,156
				FLOOR COVER	99	N/A	1.00	C	OPA	N	OPEN PORCH	142		42.70	6,063
				INT FINISH	99	N/A	1.00	+	WDK	N	WOOD DECK	129		31.60	4,076
				HEATING/COOLING	1	FORCED AIR	1.00								
				FUEL SOURCE	2	GAS	1.00								
				ARPUD	0		1.00								
				AFFORDABLE	0		1.00								

TOTAL RCN	305,468	
CONDITION ELEM	CD	
EXTERIOR		
INTERIOR		
KITCHEN		
BATHS		
HEAT		
ELECT		
EFF.YR/AGE	1955 / 66	
COND	56 56 %	
FUNC	0	
ECON	0	
DEPR	56 % GD	44
RCNLD	\$134,400	