

Key: 1456

Town of E. BRIDGEWATER - Fiscal Year 2023

12/6/2022 6:38 pm SEQ #: 1.216

LEGAL

CURRENT OWNER				PARCEL ID				LOCATION			
BARTUS JOSHUA D & JULIE M				36-7-0				529 CRESCENT ST			
529 CRESCENT ST				TRANSFER HISTORY				DOS	T	SALE PRICE	BK-PG (Cert)
E BRIDGEWATER, MA 02333				BARTUS JOSHUA D & JULIE M				05/29/2015	QS	349,900	45608-248
				KELLEY CHRISTOPHER P				10/19/2012	QS	299,900	42121-123
				BROWN BUILDERS INC				06/29/2012	S	93,500	41580-326

CLASS	CLASS%	DESCRIPTION			BN ID	BN	CARD	
1010	100	SINGLE FAMILY				1	1 of 1	
PMT NO	PMT DT	TY	DESC	AMOUNT	INSP	BY	1st	%
3200	03/14/2017	3	ALTERATIONS	29,000	05/08/2018	SLB	100	100
2841	03/04/2016	51	FIELD REVIEW	24,000	05/18/2016	PW	0	0
		3	ALTERATIONS		0	0		
		6	CYCL GROWTH		0	0		
	07/23/2015	99	OTHER		01/15/2016	SD	0	0

LAND

CD	T	AC/SF/UN	Ngh	Inf1	Inf2	ADJ BASE	SAF	Inf3	Lpi	VC	CREDIT AMT	ADJ VALUE	
100	S	43,560	3	1.00	100	1.00	100	1.00	188,000	1.00	100	3	1.00
300	A	0.860	3	1.00	100	1.00	100	1.00	5,700	1.00	100	ELP	1.00
TOTAL												1.860 Acres	

TOTAL	ZONING	FRNT	ASSESSED	CURRENT	PREVIOUS
1.860 Acres	RES 3	0	LAND	192,900	175,500
	FACTOR 100		BUILDING	298,000	281,100
	PHY 100		DETACHED	2,500	2,300
			OTHER	0	0
			TOTAL	493,400	458,900

DETACHED

TY	QUAL	COND	DIM/NOTE	YB	UNITS	ADJ PRICE	RCNLD
SHF	A	1.00	40 0.60		200	20.44	2,500

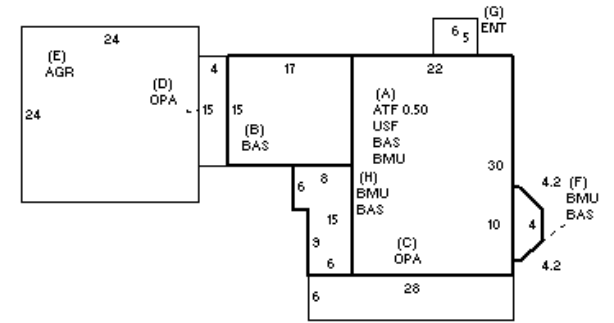

BUILDING

BUILDING	CD	ADJ	DESC	MEASURE	5/8/2018	SLB
MODEL	1		RESIDENTIAL	LIST		
STYLE	7	0.90	CONVENTIONAL [100%]	REVIEW	3/26/2013	ER
QUALITY	A	1.00	AVERAGE [100%]			
FRAME	1	1.00	WOOD FRAME [100%]			

BLDG COMMENTS

G

YEAR BLT	1900	SIZE ADJ	1.000	ELEMENT	CD	DESCRIPTION	ADJ	S	BAT	T	DESCRIPTION	UNITS	YB	ADJ PRICE	RCN	TOTAL RCN	372,514
NET AREA	2,038	DETAIL ADJ	0.927	FOUNDATION	5	BRICK/STONE	1.00	+	BMU	N	BSMT UNFINISHED	793		41.78	33,131	CONDITION ELEM	CD
\$NLA(RCN)	\$183	OVERALL	1.000	EXT COVER	1	WD SHINGLES	1.00	A	USF	L	UPPER STORY FIN	660	1900	138.82	91,621	EXTERIOR	G
				ROOF SHAPE	1	GABLE	1.00	A	ATF	L	ATTIC FINISH	330	1900	98.83	32,614	INTERIOR	G
				ROOF COVER	1	ASPH SHINGLES	1.00	+	BAS	L	BASE AREA	1,048	1900	152.76	160,096	KITCHEN	G
				FLOOR COVER	99	N/A	1.00	+	OPA	N	OPEN PORCH	228		42.70	9,736	BATHS	G
				INT FINISH	99	N/A	1.00	E	AGR	N	ATT GARAGE	576		67.88	39,101	HEAT	U
				HEATING/COOLING	9	WARM/COOL AIR	1.03	G	ENT	N	ENCLOSED ENTRY	30		81.10	2,433	ELECT	U
				FUEL SOURCE	2	GAS	1.00										
				ARPUD	0		1.00										
				AFFORDABLE	0		1.00										
EFF.YR/AGE 2001 / 20																	
COND 20 20 %																	
FUNC 0																	
ECON 0																	
DEPR 20 % GD 80																	
RCNLD \$298,000																	