

Key: 1472

Town of E. BRIDGEWATER - Fiscal Year 2023

12/6/2022 6:38 pm SEQ #: 1.232

LEGAL

CURRENT OWNER				PARCEL ID				LOCATION			
MCKENZIE DONNA L & ROBERT J				37-8-0				295 CRESCENT ST			
295 CRESCENT ST				TRANSFER HISTORY				DOS	T	SALE PRICE	BK-PG (Cert)
E BRIDGEWATER, MA 02333				MCKENZIE DONNA L & ROBERT				10/27/2010	H	220,000	39177-329
				MORETTI MARIO M SR TR				12/28/2006	A	100	33897-158
				MORETTI MARIO & JULIA M				05/14/1953	QS		2272-001

CLASS	CLASS%	DESCRIPTION		BN ID	BN	CARD	
1010	100	SINGLE FAMILY			1	1 of 1	
PMT NO	PMT DT	TY	DESC	AMOUNT	INSP	BY	1st %
2370	03/12/2015	6	CYCL GROWTH		03/23/2020	SD	0 0
2278	11/18/2014	3	ALTERATIONS	19,000			0 0
	11/26/2012	3	ALTERATIONS	1,164			0 0
752	04/14/2011	6	CYCL GROWTH		11/26/2012	LFF	0 0
		3	ALTERATIONS	1,000			0 0

LAND

CD	T	AC/SF/UN	Ngh	Infl1	Infl2	ADJ BASE	SAF	Infl3	Lpi	VC	CREDIT AMT	ADJ VALUE
100	S	43,560 3	1.00	100	1.00	188,000	1.00	100	1.00	3	1.00	188,000
300	A	0.582 3	1.00	100	1.00	5,700	1.00	100	1.00	ELP	1.00	3,320

DETACHED

TOTAL	1.582 Acres	ZONING	FRNT	0	ASSESSED	CURRENT	PREVIOUS
Ngh	RES 3	N O T E	T 4495/ PLAN 10-379/ ESMT		LAND	191,300	174,000
Infl1	FACTOR 100		BUILDING	129,600	129,100		
Infl2	PHY 100		DETACHED	0	0		
			OTHER	0	0		
			TOTAL		320,900	303,100	

TY	QUAL	COND	DIM/NOTE	YB	UNITS	ADJ PRICE	RCNLD

PHOTO 03/24/2020



BLDG COMMENTS
IN-LAW APT

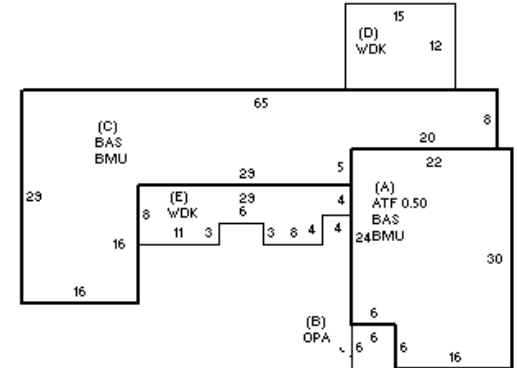

BUILDING

BUILDING	CD	ADJ	DESC	MEASURE	3/23/2020	SD
MODEL	1		RESIDENTIAL	LIST	3/23/2020	SD
STYLE	7	0.90	CONVENTIONAL [100%]	REVIEW	3/26/2013	ER
QUALITY	A	1.00	AVERAGE [100%]			
FRAME	1	1.00	WOOD FRAME [100%]			

YEAR BLT	1850	SIZE ADJ	1.000	ELEMENT	CD	DESCRIPTION	ADJ	S	BAT	T	DESCRIPTION	UNITS	YB	ADJ PRICE	RCN	TOTAL RCN	359,872
NET AREA	1,937	DETAIL ADJ	0.918	FOUNDATION	5	BRICK/STONE	1.00	+	BMU	N	BSMT UNFINISHED	1,625		34.60	56,218		
\$NLA(RCN)	\$186	OVERALL	1.000	EXT COVER	4	VINYL	1.00	+	BAS	L	BASE AREA	1,625	1850	153.84	249,988		
				ROOF SHAPE	1	GABLE	1.00	A	ATF	L	ATTIC FINISH	312	1850	99.53	31,052		
				ROOF COVER	1	ASPH SHINGLES	1.00	B	OPA	N	OPEN PORCH	36		42.69	1,537		
				FLOOR COVER	99	N/A	1.00	+	WDK	N	WOOD DECK	378		31.60	11,945		
				INT FINISH	99	N/A	1.00		KIT	O	XTRA KITCHEN	1		5,387.00	5,387		
				HEATING/COOLING	2	HOT WATER	1.02										
				FUEL SOURCE	99	N/A	1.00										
				ARPUD	0		1.00										
				AFFORDABLE	0		1.00										

CONDITION ELEM	CD
EXTERIOR	
INTERIOR	
KITCHEN	
BATHS	
HEAT	
ELECT	

EFF.YR/AGE	1951 / 70
COND	64 64 %
FUNC	0
ECON	0
DEPR	64 % GD 36
RCNLD	\$129,600