

Key: 1912

Town of E. BRIDGEWATER - Fiscal Year 2023

12/6/2022 6:38 pm SEQ #: 1.624

LEGAL

CURRENT OWNER				PARCEL ID				LOCATION			
ANDERSON PAMELA B & ROBYN R 147 CHESTNUT STREET E BRIDGEWATER, MA 02333				49-10-0				147 CHESTNUT ST			
TRANSFER HISTORY				DOS	T	SALE PRICE	BK-PG (Cert)				
ANDERSON PAMELA B & ROBYN				06/09/2006	A		1 32832-266				
ANDERSON WILLIAM F & PAME				09/17/1970	QS		3619-123				

CLASS	CLASS%	DESCRIPTION			BN ID	BN	CARD	
1010	100	SINGLE FAMILY				1	1 of 1	
PMT NO	PMT DT	TY	DESC	AMOUNT	INSP	BY	1st	%
2945	05/24/2016	6	CYCL GROWTH		09/16/2020	SD	0	0
		3	ALTERATIONS	18,700	05/10/2017	SLB	100	100
		6	CYCL GROWTH		06/11/2013		0	0
		6	CYCL GROWTH		04/30/2009		0	0
		6	CYCL GROWTH		06/16/2008		0	0

LAND

CD	T	AC/SF/UN	Ngh	Inf1	Inf2	ADJ BASE	SAF	Inf3	Lpi	VC	CREDIT AMT	ADJ VALUE
100	S	43,560 3	1.00	100	1.00	188,000	1.00	100	1.00	3	1.00	188,000
300	A	0.810 3	1.00	100	1.00	5,700	1.00	100	1.00	ELP	1.00	4,620

TOTAL	1.810 Acres	ZONING	FRNT 0	ASSESSED	CURRENT	PREVIOUS
Ngh	RES 3	NOTE LOT 3/ T 9711	LAND	192,600	175,200	
Inf1	FACTOR 100		BUILDING	345,600	297,300	
Inf2	PHY 100		DETACHED	0	0	
			OTHER	0	0	
			TOTAL	538,200	472,500	

DETACHED

TY	QUAL	COND	DIM/NOTE	YB	UNITS	ADJ PRICE	RCNLD

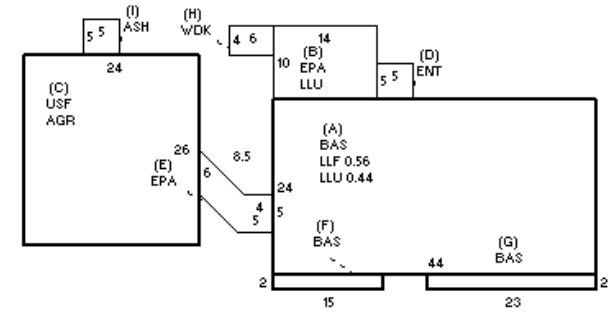

BLDG COMMENTS

BUILDING

BUILDING	CD	ADJ	DESC	MEASURE	9/16/2020	SD
MODEL	1		RESIDENTIAL	LIST	9/16/2020	SD
STYLE	2	1.05	RAISED RANCH [100%]	REVIEW	3/28/2013	ER
QUALITY	A	1.00	AVERAGE [100%]			
FRAME	1	1.00	WOOD FRAME [100%]			

YEAR BLT	1972	SIZE ADJ	1.000	ELEMENT	CD	DESCRIPTION	ADJ
NET AREA	1,756	DETAIL ADJ	1.071	FOUNDATION	4	CONT BSMT WALL	1.00
\$NLA(RCN)	\$252	OVERALL	1.000	EXT COVER	1	WD SHINGLES	1.00
CAPACITY		UNITS	ADJ	ROOF SHAPE	1	GABLE	1.00
STORIES	1	1.00		ROOF COVER	1	ASPH SHINGLES	1.00
ROOMS	7	1.00		FLOOR COVER	99	N/A	1.00
BEDROOMS	3	1.00		INT FINISH	99	N/A	1.00
BATHROOMS	2	1.00		HEATING/COOLING	2	HOT WATER	1.02
# 1/2 BATHS	0	1.00		FUEL SOURCE	99	N/A	1.00
TOT FIXTURES	6	\$4,370		ARPUD	0		1.00
# UNITS	1	1.00		AFFORDABLE	0		1.00

S	BAT	T	DESCRIPTION	UNITS	YB	ADJ PRICE	RCN	TOTAL RCN	443,078
+	LLU	N	LOWER LEVEL UNF	605		58.70	35,511	CONDITION ELEM CD	
A	LLF	N	LOWER LEVEL FIN	591		113.65	67,170	EXTERIOR	
C	AGR	N	ATT GARAGE	624		66.69	41,615	INTERIOR	
C	USF	L	UPPER STORY FIN	624	2008	144.28	90,029	KITCHEN	
D	ENT	N	ENCLOSED ENTRY	25		81.12	2,028	BATHS	G
+	EPA	N	ENCLOSED PORCH	196		74.40	14,582	HEAT	
+	BAS	L	BASE AREA	1,132	1972	158.77	179,727	ELECT	
H	WDK	N	WOOD DECK	24		31.58	758		
I	ASH	N	ATT SHED	25		18.76	469		
	F21	O	FPL 2S 1OP	1		6,819.00	6,819		
								EFF.YR/AGE	1996 / 25
								COND	22 22 %
								FUNC	0
								ECON	0
								DEPR	22 % GD 78
								RCNLD	\$345,600