

Key: 1941

Town of E. BRIDGEWATER - Fiscal Year 2023

12/6/2022 6:38 pm SEQ #: 1.663

LEG  
AL  
LAND

| CURRENT OWNER  |   |          |      | PARCEL ID  |      |            |              | LOCATION     |      |     |            |           |
|--|---|----------|------|------------|------|------------|--------------|--------------|------|-----|------------|-----------|
| ALDEN-PERKINS AUTUMN<br>37 STRONG AVE<br>E BRIDGEWATER, MA 02333 |   |          |      | 50-31-0    |      |            |              | 37 STRONG AV |      |     |            |           |
| TRANSFER HISTORY   |   |          |      | DOS        | T    | SALE PRICE | BK-PG (Cert) |              |      |     |            |           |
| ALDEN-PERKINS AUTUMN   |   |          |      | 08/31/2018 | A    | 428,500    | 50246-080    |              |      |     |            |           |
| ALDEN GERALD & JANICE  |   |          |      | 02/12/1987 | QS   |            | 7482-222     |              |      |     |            |           |
| ALDEN MARY M   |   |          |      | 02/11/1987 | QS   |            | 7482-222     |              |      |     |            |           |
| CD   | T | AC/SF/UN | Ngh  | Inf1       | Inf2 | ADJ BASE   | SAF          | Inf3         | Lpi  | VC  | CREDIT AMT | ADJ VALUE |
| 100  | S | 43,560 3 | 1.00 | 100        | 1.00 | 188,000    | 1.00         | 100          | 1.00 | 3   | 1.00       | 188,000   |
| 300  | A | 4,648 3  | 1.00 | 100        | 1.00 | 5,700      | 1.00         | 100          | 1.00 | ELP | 1.00       | 26,490    |

| CLASS     | CLASS%     | DESCRIPTION |             |        | BN ID      | BN  | CARD   |     |
|-----------|------------|-------------|-------------|--------|------------|-----|--------|-----|
| 1040      | 100        | TWO FAMILY  |             |        |            | 1   | 1 of 1 |     |
| PMT NO    | PMT DT     | TY          | DESC        | AMOUNT | INSP       | BY  | 1st    | %   |
| BP-31-403 | 08/24/2021 | 3           | ALTERATIONS | 2,859  |            |     |        | 0   |
| BP-21-402 | 08/24/2021 | 3           | ALTERATIONS | 10,120 |            |     |        | 0   |
|           |            | 6           | CYCL GROWTH |        | 10/28/2018 | SD  |        | 0   |
|           |            | 5           | SPLIT/SUB   |        | 07/24/2017 | SLB | 100    | 100 |
|           |            | 6           | CYCL GROWTH |        | 07/09/2014 |     |        | 0   |

LAND

| TOTAL | 5.648 Acres |  | ZONING                             | FRNT | 0     | ASSESSED     | CURRENT        | PREVIOUS       |
|-------|-------------|--|------------------------------------|------|-------|--------------|----------------|----------------|
| Ngh   | RES 3       |  | NOTE<br>land area changed for fy18 |      |       | LAND         | 214,500        | 195,200        |
| Inf1  | FACTOR 100  |  |                                    |      |       | BUILDING     | 282,500        | 278,000        |
| Inf2  | PHY 100     |  |                                    |      |       | DETACHED     | 12,400         | 11,600         |
|       |             |  |                                    |      | OTHER | 0            | 0              |                |
|       |             |  |                                    |      |       | <b>TOTAL</b> | <b>509,400</b> | <b>484,800</b> |

DETACHED

| TY  | QUAL | COND | DIM/NOTE | YB | UNITS | ADJ PRICE | RCNLD |
|-----|------|------|----------|----|-------|-----------|-------|
| SHF | A    | 1.00 | 40 0.60  |    | 200   | 20.44     | 2,500 |
| SHF | A    | 1.00 | 40 0.60  |    | 200   | 20.44     | 2,500 |
| IPV | A    | 1.00 | 30 0.70  |    | 468   | 22.56     | 7,400 |

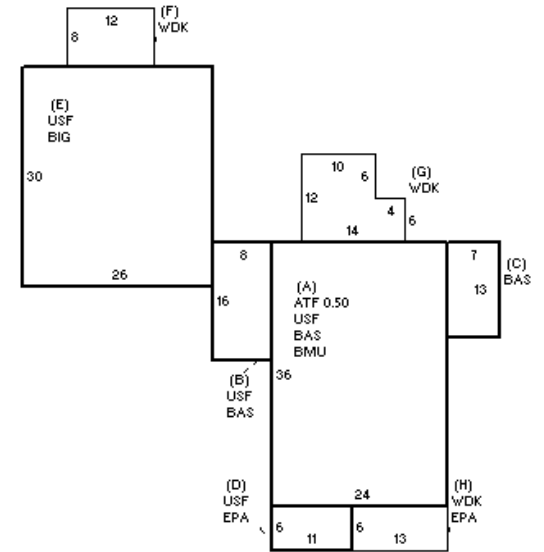

BUILDING

| BUILDING | CD | ADJ  | DESC                | MEASURE | 10/28/2018 | SD |
|----------|----|------|---------------------|---------|------------|----|
| MODEL    | 1  |      | RESIDENTIAL         | LIST    |            |    |
| STYLE    | 7  | 0.90 | CONVENTIONAL [100%] | REVIEW  | 3/28/2013  | ER |
| QUALITY  | A  | 1.00 | AVERAGE [100%]      |         |            |    |
| FRAME    | 1  | 1.00 | WOOD FRAME [100%]   |         |            |    |

BLDG COMMENTS

BLDG

| YEAR BLT   | 1900  | SIZE ADJ   | 1.000 | ELEMENT         | CD | DESCRIPTION   | ADJ  | S | BAT | T | DESCRIPTION     | UNITS | YB   | ADJ PRICE | RCN     | TOTAL RCN      | 543,243    |
|------------|-------|------------|-------|-----------------|----|---------------|------|---|-----|---|-----------------|-------|------|-----------|---------|----------------|------------|
| NET AREA   | 3,353 | DETAIL ADJ | 0.990 | FOUNDATION      | 5  | BRICK/STONE   | 1.00 | A | BMU | N | BSMT UNFINISHED | 864   |      | 40.60     | 35,078  |                |            |
| \$NLA(RCN) | \$162 | OVERALL    | 1.000 | EXT COVER       | 4  | VINYL         | 1.00 | + | USF | L | UPPER STORY FIN | 1,838 | 1900 | 129.45    | 237,926 |                |            |
|            |       |            |       | ROOF SHAPE      | 1  | GABLE         | 1.00 | A | ATF | L | ATTIC FINISH    | 432   | 1900 | 92.16     | 39,813  |                |            |
|            |       |            |       | ROOF COVER      | 1  | ASPH SHINGLES | 1.00 | + | BAS | L | BASE AREA       | 1,083 | 1900 | 142.45    | 154,274 |                |            |
|            |       |            |       | FLOOR COVER     | 99 | N/A           | 1.00 | + | EPA | N | ENCLOSED PORCH  | 144   |      | 74.40     | 10,714  |                |            |
|            |       |            |       | INT FINISH      | 99 | N/A           | 1.00 | E | BIG | N | BUILT-IN GARAGE | 780   |      | 63.24     | 49,330  |                |            |
|            |       |            |       | HEATING/COOLING | 1  | FORCED AIR    | 1.00 | + | WDK | N | WOOD DECK       | 318   |      | 31.60     | 10,049  |                |            |
|            |       |            |       | FUEL SOURCE     | 99 | N/A           | 1.00 |   |     |   |                 |       |      |           |         |                |            |
|            |       |            |       | ARPUD           | 0  |               | 1.00 |   |     |   |                 |       |      |           |         |                |            |
|            |       |            |       | AFFORDABLE      | 0  |               | 1.00 |   |     |   |                 |       |      |           |         |                |            |
|            |       |            |       |                 |    |               |      |   |     |   |                 |       |      |           |         | CONDITION ELEM | CD         |
|            |       |            |       |                 |    |               |      |   |     |   |                 |       |      |           |         | EXTERIOR       |            |
|            |       |            |       |                 |    |               |      |   |     |   |                 |       |      |           |         | INTERIOR       |            |
|            |       |            |       |                 |    |               |      |   |     |   |                 |       |      |           |         | KITCHEN        |            |
|            |       |            |       |                 |    |               |      |   |     |   |                 |       |      |           |         | BATHS          |            |
|            |       |            |       |                 |    |               |      |   |     |   |                 |       |      |           |         | HEAT           |            |
|            |       |            |       |                 |    |               |      |   |     |   |                 |       |      |           |         | ELECT          |            |
|            |       |            |       |                 |    |               |      |   |     |   |                 |       |      |           |         | EFF.YR/AGE     | 1959 / 62  |
|            |       |            |       |                 |    |               |      |   |     |   |                 |       |      |           |         | COND           | 48 48 %    |
|            |       |            |       |                 |    |               |      |   |     |   |                 |       |      |           |         | FUNC           | 0          |
|            |       |            |       |                 |    |               |      |   |     |   |                 |       |      |           |         | ECON           | 0          |
|            |       |            |       |                 |    |               |      |   |     |   |                 |       |      |           |         | DEPR           | 48 % GD 52 |
|            |       |            |       |                 |    |               |      |   |     |   |                 |       |      |           |         | RCNLD          | \$282,500  |