

Key: 1982

Town of E. BRIDGEWATER - Fiscal Year 2023

12/6/2022 6:38 pm SEQ #: 1.691

LEGALS

CURRENT OWNER				PARCEL ID				LOCATION			
BRENNER KEVIN & STINCHFIELD				50-66-0				380 CENTRAL ST			
JENNA				TRANSFER HISTORY				DOS	T	SALE PRICE	BK-PG (Cert)
380 CENTRAL ST				BRENNER KEVIN & STINCHFIELD				11/20/2014	U	270,000	44962-201
E BRIDGEWATER, MA 02333				MCNALLY AGNES M				08/19/2013	A	1 43504-223	
				MCNALLY AGNES M				01/29/1992	A	1 10726-250	

CLASS	CLASS%	DESCRIPTION			BN ID	BN	CARD	
1010	100	SINGLE FAMILY				1	1 of 1	
PMT NO	PMT DT	TY	DESC	AMOUNT	INSP	BY	1st	%
2437	04/26/2015	6	CYCL GROWTH		05/16/2015	NR	100	100
		3	ALTERATIONS	18,000			0	0
		51	FIELD REVIEW		01/06/2015	PW	0	0
31658	11/10/2014	3	ALTERATIONS	9,000			0	0
		51	FIELD REVIEW		10/01/2013	LF	0	0

LAND

CD	T	AC/SF/UN	Ngh	Infl1	Infl2	ADJ BASE	SAF	Infl3	Lpi	VC	CREDIT AMT	ADJ VALUE
100	S	29,040 3	1.00	100	1.00	188,000	1.40	100	1.00	3	1.00	175,470

TOTAL	29,040 SF	ZONING	FRNT	0	ASSESSED	CURRENT	PREVIOUS
Ngh	RES 3	NOTE			LAND	175,500	159,600
Infl1	FACTOR 100		BUILDING	259,200	236,800		
Infl2	PHY 100		DETACHED	0	0		
			OTHER	0	0		
			TOTAL	434,700	396,400		

DETAILED

TY	QUAL	COND	DIM/NOTE	YB	UNITS	ADJ PRICE	RCNLD

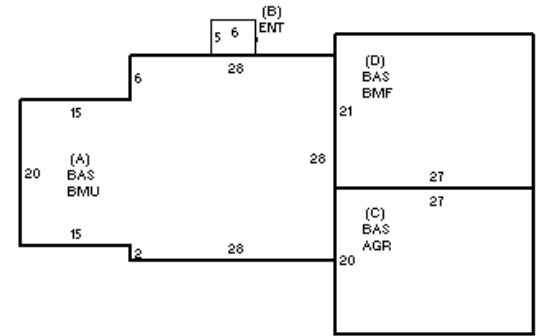

BUILDING

BUILDING	CD	ADJ	DESC	MEASURE	5/16/2015	NR
MODEL	1		RESIDENTIAL	LIST		
STYLE	3	1.05	SPLIT LEVEL [100%]	REVIEW	3/28/2013	ER
QUALITY	A	1.00	AVERAGE [100%]			
FRAME	1	1.00	WOOD FRAME [100%]			

BLDG COMMENTS

INDING

YEAR BLT	1960	SIZE ADJ	1.000	ELEMENT	CD	DESCRIPTION	ADJ	S	BAT	T	DESCRIPTION	UNITS	YB	ADJ PRICE	RCN	TOTAL RCN	498,523
NET AREA	2,191	DETAIL ADJ	1.071	FOUNDATION	4	CONT BSMT WALL	1.00	A	BMU	N	BSMT UNFINISHED	1,084		34.49	37,389	CONDITION ELEM	CD
\$NLA(RCN)	\$228	OVERALL	1.000	EXT COVER	1	WD SHINGLES	1.00	+	BAS	L	BASE AREA	2,191	1960	172.58	378,113	EXTERIOR	F
				ROOF SHAPE	1	GABLE	1.00	B	ENT	N	ENCLOSED ENTRY	30		81.10	2,433	INTERIOR	F
				ROOF COVER	1	ASP SHINGLES	1.00	C	AGR	N	ATT GARAGE	540		68.87	37,188	KITCHEN	F
				FLOOR COVER	1	HARDWOOD	1.00	D	BMF	N	BSMT FINISH-SEP	567		48.51	27,504	BATHS	F
				INT FINISH	99	N/A	1.00		F22	O	FPL 2S 2OP	1		9,341.00	9,341	HEAT	O
				HEATING/COOLING	2	HOT WATER	1.02									ELECT	O
				FUEL SOURCE	1	OIL	1.00										
				ARPUD	0		1.00										
				AFFORDABLE	0		1.00										
																EFF.YR/AGE	1959 / 62
																COND	48 48 %
																FUNC	0
																ECON	0
																DEPR	48 % GD 52
																RCNLD	\$259,200