

Key: 2052

Town of E. BRIDGEWATER - Fiscal Year 2023

12/6/2022 6:38 pm SEQ #: 1.764

LEG  
AL  
LAND

CURRENT OWNER				PARCEL ID				LOCATION				
REVERDES JOHN 41 OREGON ST E BRIDGEWATER, MA 02333				52-26-0				41 OREGON ST				
TRANSFER HISTORY				DOS	T	SALE PRICE	BK-PG (Cert)					
REVERDES JOHN				08/26/2010	S	106,000	38893-146					
U.S. BANK NATIONAL ASSOCI				10/19/2009	L	238,000	37820-083					
ZEWIEY MARK A				04/20/1988	QS	140,000	8401-200					
CD	T	AC/SF/UN	Ngh	Inf1	Inf2	ADJ BASE	SAF	Inf3	Lpi	VC	CREDIT AMT	ADJ VALUE
100	S	43,560	3	1.00	100	1.00	100	1.00	1.00	3	1.00	188,000
300	A	0.325	3	1.00	100	1.00	100	1.00	ELP	1.00		1,850

CLASS	CLASS%	DESCRIPTION		BN ID	BN	CARD	
1010	100	SINGLE FAMILY			1	1 of 1	
PMT NO	PMT DT	TY	DESC	AMOUNT	INSP	BY	1st %
3277	05/10/2017	6	CYCL GROWTH		05/04/2021	SD	0 0
1750	10/09/2013	3	ALTERATIONS	24,500			0 0
	06/26/2013	3	ALTERATIONS	500			0 0
	02/07/2013	6	CYCL GROWTH		10/07/2013	SLB	0 0
		6	CYCL GROWTH		02/07/2013	LFF	0 0

TOTAL	1.325 Acres	ZONING	FRNT	0	ASSESSED	CURRENT	PREVIOUS
Ngh	RES 3	NOTE c/w 52/51	LAND	189,900	172,700		
Inf1	FACTOR 100		BUILDING	256,800	247,300		
Inf2	PHY 100		DETACHED	6,800	6,400		
			OTHER	0	0		
			TOTAL	453,500	426,400		

TY	QUAL	COND	DIM/NOTE	YB	UNITS	ADJ PRICE	RCNLD
IPV	A	1.00	40 0.60	2005	530	21.28	6,800

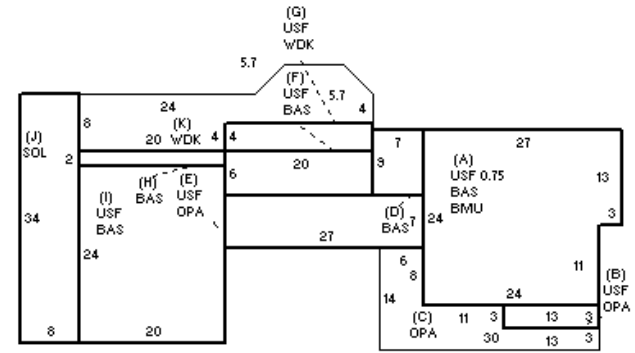

BUILDING	CD	ADJ	DESC	MEASURE	5/4/2021	SD
MODEL	1		RESIDENTIAL	LIST	5/4/2021	SD
STYLE	7	0.90	CONVENTIONAL [100%]	REVIEW	3/29/2013	ER
QUALITY	A	1.00	AVERAGE [100%]			
FRAME	1	1.00	WOOD FRAME [100%]			

BLDG COMMENTS  
IN-LAW APT

DETACHED

BUILDING

YEAR BLT	1900	SIZE ADJ	1.000	ELEMENT	CD	DESCRIPTION	ADJ	S	BAT	T	DESCRIPTION	UNITS	YB	ADJ PRICE	RCN	TOTAL RCN	450,597														
NET AREA	2,959	DETAIL ADJ	0.918	FOUNDATION	5	BRICK/STONE	1.00	A	BMU	N	BSMT UNFINISHED	615		45.80	28,169																
\$NLA(RCN)	\$152	OVERALL	1.000	EXT COVER	4	VINYL	1.00	+	USF	L	UPPER STORY FIN	1,369	1900	126.72	173,478																
				ROOF SHAPE	1	GABLE	1.00	+	OPA	N	OPEN PORCH	417		42.70	17,806																
				ROOF COVER	1	ASPH SHINGLES	1.00	+	BAS	L	BASE AREA	1,318	1900	139.45	183,790																
				FLOOR COVER	99	N/A	1.00	+	WDK	N	WOOD DECK	368		31.60	11,629																
				INT FINISH	99	N/A	1.00	J	SOL	L	SOL/ 3 SEASON	272	1900	93.18	25,344																
				HEATING/COOLING	2	HOT WATER	1.02				XTRA KITCHEN	1		5,387.00	5,387																
				FUEL SOURCE	99	N/A	1.00																								
				ARPUD	0		1.00																								
				AFFORDABLE	0		1.00																								
				<table border="1"> <thead> <tr> <th>CONDITION ELEM</th> <th>CD</th> </tr> </thead> <tbody> <tr> <td>EXTERIOR</td> <td></td> </tr> <tr> <td>INTERIOR</td> <td></td> </tr> <tr> <td>KITCHEN</td> <td></td> </tr> <tr> <td>BATHS</td> <td></td> </tr> <tr> <td>HEAT</td> <td></td> </tr> <tr> <td>ELECT</td> <td></td> </tr> </tbody> </table>														CONDITION ELEM	CD	EXTERIOR		INTERIOR		KITCHEN		BATHS		HEAT		ELECT	
CONDITION ELEM	CD																														
EXTERIOR																															
INTERIOR																															
KITCHEN																															
BATHS																															
HEAT																															
ELECT																															
				EFF.YR/AGE		1963 / 58		COND		43 43 %		FUNC		0		ECON		0													
				DEPR		43 % GD		57		RCNLD		\$256,800																			