

Key: 2254

Town of E. BRIDGEWATER - Fiscal Year 2023

12/6/2022 6:38 pm SEQ #: 1.948

LEGAL

LAND

DETACHED

BUILDING

CURRENT OWNER				PARCEL ID				LOCATION			
NORRMAN THOMAS W & SHEILA A 1277 WASHINGTON ST E BRIDGEWATER, MA 02333				57-19-0				1277 WASHINGTON ST			
TRANSFER HISTORY				DOS	T	SALE PRICE	BK-PG (Cert)				
NORRMAN THOMAS W & SHEILA				02/01/1994	QS	123,600	12634-229				
DOMIGAN GEORGE P JR & JEA				08/10/1971	QS		3697-392				

CLASS	CLASS%	DESCRIPTION			BN ID	BN	CARD	
1010	100	SINGLE FAMILY				1	1 of 1	
PMT NO	PMT DT	TY	DESC	AMOUNT	INSP	BY	1st	%
BP-21-72	03/02/2021	6	CYCL GROWTH	4,000	05/17/2021	SLB	100	100
		3	ALTERATIONS		05/17/2021	SLB	100	100
		6	CYCL GROWTH		01/14/2015	LF	0	0
419	03/05/2002	51	FIELD REVIEW	17,000	04/25/2014	LF	0	0
		3	ALTERATIONS		04/08/2004	KB	100	100

CD	T	AC/SF/UN	Ngh	Inf1	Inf2	ADJ BASE	SAF	Inf3	Lpi	VC	CREDIT AMT	ADJ VALUE
100	S	43,560	3	1.00	100	188,000	1.00	100	3	1.00		188,000
300	A	0.030	3	1.00	100	5,700	1.00	100	ELP	1.00		170

TOTAL	1.030 Acres		ZONING	FRNT	0	ASSESSED	CURRENT	PREVIOUS
Ngh	RES 3		NOTE			LAND	188,200	171,200
Inf1	FACTOR 100			BUILDING	203,300	187,000		
Inf2	PHY 100			DETACHED	15,500	14,800		
				OTHER	0	0		
				TOTAL	407,000	373,000		

TY	QUAL	COND	DIM/NOTE	YB	UNITS	ADJ PRICE	RCNLD
SHF	A	1.00	40 0.60	1990	780	14.29	6,700
IPV	A	1.00	30 0.70		648	19.48	8,800

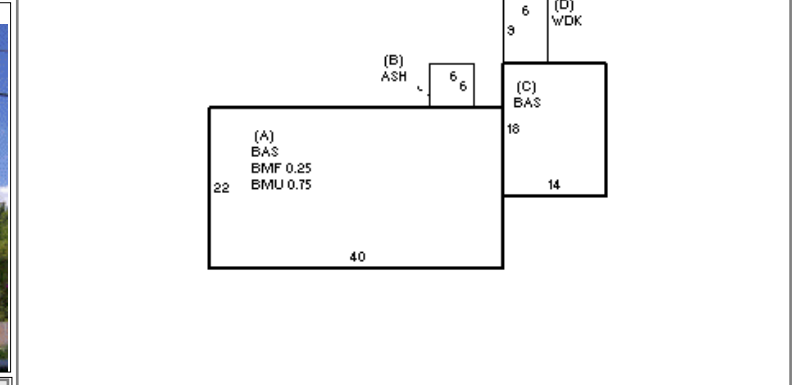

BUILDING	CD	ADJ	DESC	MEASURE	5/17/2021	SLB
MODEL	1		RESIDENTIAL	LIST	5/17/2021	SLB
STYLE	1	1.00	RANCH [100%]	REVIEW	4/2/2013	ER
QUALITY	A	1.00	AVERAGE [100%]			
FRAME	1	1.00	WOOD FRAME [100%]			

BLDG COMMENTS

YEAR BLT	1964	SIZE ADJ	1.000	ELEMENT	CD	DESCRIPTION	ADJ	S	BAT	T	DESCRIPTION	UNITS	YB	ADJ PRICE	RCN	TOTAL RCN	278,435
NET AREA	1,132	DETAIL ADJ	1.000	FOUNDATION	4	CONT BSMT WALL	1.00	A	BMU	N	BSMT UNFINISHED	660		40.39	26,658	CONDITION ELEM	CD
\$NLA(RCN)	\$246	OVERALL	1.000	EXT COVER	4	VINYL	1.00	A	BMF	N	BSMT FINISH-SEP	220		56.80	12,497	EXTERIOR	
CAPACITY		UNITS	ADJ	ROOF SHAPE	1	GABLE	1.00	B	ASH	N	ATT SHED	36		18.75	675	INTERIOR	
STORIES	1	1.00		ROOF COVER	1	ASPH SHINGLES	1.00	+	BAS	L	BASE AREA	1,132	1964	207.47	234,859	KITCHEN	
ROOMS	5	1.00		FLOOR COVER	99	N/A	1.00	D	WDK	N	WOOD DECK	54		31.59	1,706	BATHS	
BEDROOMS	3	1.00		INT FINISH	99	N/A	1.00									HEAT	
BATHROOMS	1	1.00		HEATING/COOLING	1	FORCED AIR	1.00									ELECT	
# 1/2 BATHS	0	1.00		FUEL SOURCE	2	GAS	1.00										
TOT FIXTURES	3	\$2,040		ARPUD	0		1.00										
# UNITS	1	1.00		AFFORDABLE	0		1.00										
																EFF.YR/AGE	1980 / 41
																COND	27 27 %
																FUNC	0
																ECON	0
																DEPR	27 % GD 73
																RCNLD	\$203,300