

Key: 2417

Town of E. BRIDGEWATER - Fiscal Year 2023

12/6/2022 6:38 pm SEQ #: 2.094

LEGALS

CURRENT OWNER				PARCEL ID				LOCATION				
J & B REALTY TRUST RUDNICKI JOHN Z & BARBARA A 4 JENNIFER WAY S. EASTON, MA 02375				59-124-0				553 CENTRAL ST				
TRANSFER HISTORY				DOS	T	SALE PRICE	BK-PG (Cert)					
J & B REALTY TRUST				08/02/2016	F	350,000	47266-342					
JOHNSON BARBARA & BRUCE				10/22/2003	A	1	26848-110					
ANTHONY BARBARA				09/15/1993	QS	169,000	12208-159					
CD	T	AC/SF/UN	Ngh	Inf1	Inf2	ADJ BASE	SAF	Inf3	Lpi	VC	CREDIT AMT	ADJ VALUE
100	S	15,246	3	1.00	100	188,000	2.49	100	1.00	3	1.00	163,560

CLASS	CLASS%	DESCRIPTION			BN ID	BN	CARD	
1050	100	THREE FAMILY				1	1 of 1	
PMT NO	PMT DT	TY	DESC	AMOUNT	INSP	BY	1st	%
6			CYCL GROWTH		11/20/2020	SD	0	0
51			FIELD REVIEW		07/05/2017	PW	0	0
51			FIELD REVIEW		07/31/2013	LF	0	0
3	11/08/2004		ALTERATIONS	5,500	06/06/2005	SLB	100	100

LAND

TOTAL	15,246 SF	ZONING	FRNT	0	ASSESSED	CURRENT	PREVIOUS
Ngh	RES 3	N O T E	LOT 1/ T 14231		LAND	163,600	148,800
Inf1	FACTOR 100		BUILDING	215,600	220,500		
Inf2	PHY 100		DETACHED	0	0		
			OTHER	0	0		
			TOTAL	379,200	369,300		

DETACHED

TY	QUAL	COND	DIM/NOTE	YB	UNITS	ADJ PRICE	RCNLD

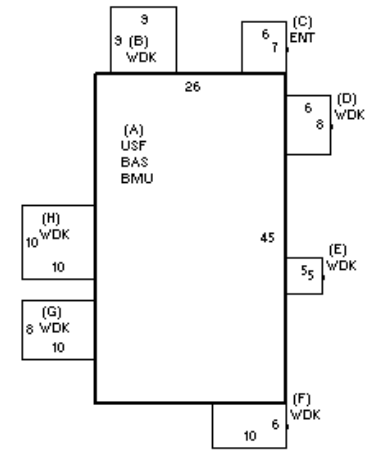

BUILDING

BUILDING	CD	ADJ	DESC	MEASURE	11/20/2020	SD
MODEL	1		RESIDENTIAL	LIST	11/20/2020	SD
STYLE	7	0.90	CONVENTIONAL [100%]	REVIEW	4/2/2013	ER
QUALITY	A	1.00	AVERAGE [100%]			
FRAME	1	1.00	WOOD FRAME [100%]			

BLDG COMMENTS

INDING

YEAR BLT	1900	SIZE ADJ	1.000	ELEMENT	CD	DESCRIPTION	ADJ	S	BAT	T	DESCRIPTION	UNITS	YB	ADJ PRICE	RCN	TOTAL RCN	431,218
NET AREA	2,340	DETAIL ADJ	1.024	FOUNDATION	4	CONT BSMT WALL	1.00	A	BMU	N	BSMT UNFINISHED	1,170		37.27	43,603		
\$NLA(RCN)	\$184	OVERALL	1.000	EXT COVER	4	VINYL	1.00	A	BAS	L	BASE AREA	1,170	1900	161.79	189,296		
				ROOF SHAPE	1	GABLE	1.00	A	USF	L	UPPER STORY FIN	1,170	1900	147.02	172,018		
				ROOF COVER	1	ASPH SHINGLES	1.00	+	WDK	N	WOOD DECK	394		31.60	12,450		
				FLOOR COVER	99	N/A	1.00	C	ENT	N	ENCLOSED ENTRY	42		81.10	3,406		
				INT FINISH	99	N/A	1.00										
				HEATING/COOLING	5	ELECTRIC BB	0.99										
				FUEL SOURCE	3	ELECTRIC	1.00										
				ARPUD	0		1.00										
				AFFORDABLE	0		1.00										
																CONDITION ELEM	CD
																EXTERIOR	
																INTERIOR	
																KITCHEN	
																BATHS	
																HEAT	
																ELECT	
																EFF.YR/AGE	1958 / 63
																COND	50 50 %
																FUNC	0
																ECON	0
																DEPR	50 % GD 50
																RCNLD	\$215,600