

Key: 2566

Town of E. BRIDGEWATER - Fiscal Year 2023

12/6/2022 6:38 pm SEQ #: 2.191

LEGALS

CURRENT OWNER				PARCEL ID				LOCATION				
CHRISTOPHER M GRAHAM LIVING TR 271 WATER ST PEMBROKE, MA 02359				61-79-0				27 SPRING ST				
TRANSFER HISTORY				DOS	T	SALE PRICE		BK-PG (Cert)				
CHRISTOPHER M GRAHAM LIVI				05/24/2017	A	1 48462-180						
GRAHAM TRACI & CHRISTOPHE				02/17/2012	A	1 40991-181						
GRAHAM TRACI				02/09/2012	L	200,000 40957-233						
CD	T	AC/SF/UN	Ngh	Infl1	Infl2	ADJ BASE	SAF	Infl3	Lpi	VC	CREDIT AMT	ADJ VALUE
100	S	21,780	7	1.00	1.00	178,600	1.80	1.00	7	0.95		160,740

CLASS	CLASS%	DESCRIPTION			BN ID	BN	CARD	
1110	100	4 TO 8 UNITS				1	1 of 1	
PMT NO	PMT DT	TY	DESC	AMOUNT	INSP	BY	1st	%
3362	08/08/2017	6	CYCL GROWTH		12/14/2017	RJM	100	100
2385	03/30/2015	3	ALTERATIONS	3,894	12/14/2017	RJM	100	100
011	03/18/2015	3	ALTERATIONS	10,000	04/29/2015	SLB	100	100
2376	03/18/2015	7	DETACHED BLD	17,500	04/29/2015	SLB	100	100

LAND

TOTAL	21,780 SF	ZONING	FRNT	0	ASSESSED	CURRENT	PREVIOUS
Ngh	RES 7	NOTE			LAND	160,700	146,200
Infl1	FACTOR 100		BUILDING	257,500	248,800		
Infl2	PHY 100		DETACHED	8,400	8,000		
			OTHER	0	0		
TOTAL					426,600	403,000	

DETACHED

TY	QUAL	COND	DIM/NOTE	YB	UNITS	ADJ PRICE	RCNLD
SHF	G	1.20	10 0.90 12X16		192	24.53	4,200
SHF	G	1.20	10 0.90 12X16		192	24.53	4,200

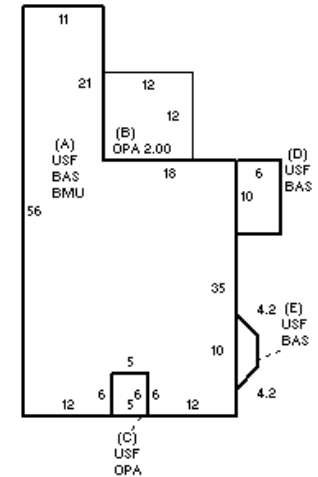

BUILDING

BUILDING	CD	ADJ	DESC	MEASURE	12/14/2017	RJM
MODEL	5		CIM-5	LIST	12/14/2017	RJM
STYLE	13	0.85	APARTMENTS [100%]	REVIEW	1/2/2018	RJM
QUALITY	A	1.00	AVERAGE [100%]			
FRAME	1	1.00	WOOD FRAME [100%]			

BLDG COMMENTS
4 APTS

LOADING

YEAR BLT	1860	SIZE ADJ	1.000	ELEMENT	CD	DESCRIPTION	ADJ	S	BAT	T	DESCRIPTION	UNITS	YB	ADJ PRICE	RCN	TOTAL RCN	367,893
NET AREA	2,624	DETAIL ADJ	0.791	FOUNDATION	4	FLR & WALL	1.00	A	BMU	N	BSMT UNF	1,216		23.90	29,062		
\$NLA(RCN)	\$140	OVERALL	1.000	EXT. COVER	4	VINYL	1.00	+	USF	L	UP-STRY FIN	1,327	1860	126.23	167,509		
				ROOF SHAPE	1	GABLE	1.00	+	OPA	N	OPEN PORCH	318		23.90	7,600		
				ROOF COVER	1	ASPH/CMP SHIN	1.00	+	BAS	L	BASE AREA	1,297	1860	126.23	163,722		
				FLOOR COVER	3	W/W CARPET	1.00										
				INT. FINISH	2	DRYWALL	1.00										
				HEATING/COOL	5	ELECTRIC BB	0.98										
				FUEL SOURCE	3	ELECTRIC	1.00										
				ARPUD	0		1.00										
				AFFORDABLE	0		1.00										
																EFF.YR/AGE	1983 / 38
																COND	30 30 %
																FUNC	0
																ECON	0
																DEPR	30 % GD 70
																RCNLD	\$257,500