

Key: 2690

Town of E. BRIDGEWATER - Fiscal Year 2023

12/6/2022 6:38 pm SEQ #: 2.298

LEGAL LAND

CURRENT OWNER				PARCEL ID				LOCATION				
188 NORTH CENTRAL STREET LLC 79 WILSON AVE WEYMOUTH, MA 02188				62-59-0				188 N CENTRAL ST				
TRANSFER HISTORY				DOS	T	SALE PRICE		BK-PG (Cert)				
188 NORTH CENTRAL STREET				10/02/2017	A	1 48999-104						
FRAWLEY CHRISTOPHER J				01/08/2002	QS	460,000 21307-215						
ROMA BERNARD A				09/26/1994	QS	265,000 13164-294						
CD	T	AC/SF/UN	Ngh	Inf1	Inf2	ADJ BASE	SAF	Inf3	Lpi	VC	CREDIT AMT	ADJ VALUE
112	U	10 APT	1.00	100	1.00	33,000	1.00	100	1.00	AG	1.10	330,000

CLASS	CLASS%	DESCRIPTION			BN ID	BN	CARD	
1120	100	> 8 UNITS				1	1 of 1	
PMT NO	PMT DT	TY	DESC	AMOUNT	INSP	BY	1st	%
104	03/15/2002	60	SITE INSPECT		12/14/2017	RJM	100	100
		51	FIELD REVIEW		09/17/2013		100	100
		6	CYCL GROWTH		03/15/2002	KEO	100	100

LEGAL LAND

TOTAL	1.150 Acres	ZONING	FRNT	0	ASSESSED	CURRENT	PREVIOUS
Ngh	APARTMENTS	NOTE	LAND	330,000	300,300		
Inf1	FACTOR 100		BUILDING	441,700	420,800		
Inf2	PHY 100		DETACHED	0	0		
			OTHER	0	0		
			TOTAL	771,700	721,100		

TY	QUAL	COND	DIM/NOTE	YB	UNITS	ADJ PRICE	RCNLD

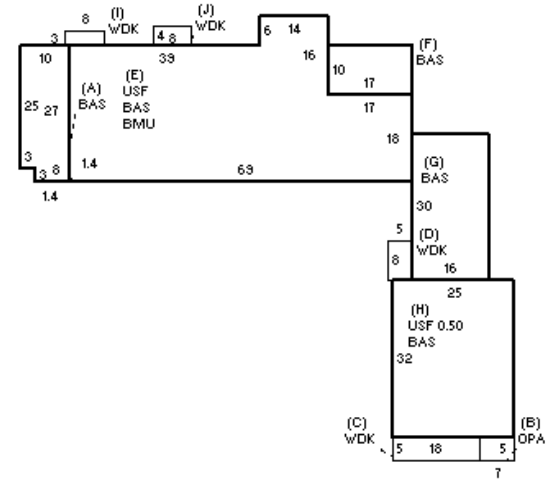

DETACHED

BUILDING	CD	ADJ	DESC	MEASURE	12/14/2017	RJM
MODEL	5		CIM-5	LIST	12/19/2017	RJM
STYLE	13	0.85	APARTMENTS [100%]	REVIEW	12/27/2017	ER
QUALITY	A	1.00	AVERAGE [100%]			
FRAME	1	1.00	WOOD FRAME [100%]			

BUILDING

YEAR BLT	1885	SIZE ADJ	1.000	ELEMENT	CD	DESCRIPTION	ADJ	S	BAT	T	DESCRIPTION	UNITS	YB	ADJ PRICE	RCN	TOTAL RCN	649,595																	
NET AREA	5,870	DETAIL ADJ	0.788	FOUNDATION	4	FLR & WALL	1.00	+	BAS	L	BASE AREA	3,596	1885	102.29	367,842	CONDITION ELEM	CD																	
\$NLA(RCN)	\$111	OVERALL	1.000	EXT. COVER	4	VINYL	1.00	+	OPA	N	OPEN PORCH	35		23.91	837	EXTERIOR	G																	
				ROOF SHAPE	1	GABLE	1.00	+	WDK	N	WOOD DECK	186		18.90	3,515	INTERIOR	A																	
				ROOF COVER	1	ASPH/CMP SHIN	1.00	E	BMU	N	BSMT UNF	1,874		23.90	44,789	CDN/APP	A																	
				FLOOR COVER	2	SOFTWOOD	0.95	+	USF	L	UP-STRY FIN	2,274	1885	102.29	232,612																			
				INT. FINISH	3	WOOD PANEL	1.05																											
				HEATING/COOL	5	ELECTRIC BB	0.98																											
				FUEL SOURCE	3	ELECTRIC	1.00																											
				ARPUD	0		1.00																											
				AFFORDABLE	0		1.00																											
<table border="1"> <thead> <tr> <th>CAPACITY</th> <th>UNITS</th> <th>ADJ</th> </tr> </thead> <tbody> <tr> <td>STORIES</td> <td>2</td> <td>1.00</td> </tr> <tr> <td>% HEATED</td> <td>100</td> <td>1.00</td> </tr> <tr> <td>% AIR COND</td> <td>0</td> <td>1.00</td> </tr> <tr> <td>% SPRINKLER</td> <td>0</td> <td>1.00</td> </tr> </tbody> </table>																	CAPACITY	UNITS	ADJ	STORIES	2	1.00	% HEATED	100	1.00	% AIR COND	0	1.00	% SPRINKLER	0	1.00			
CAPACITY	UNITS	ADJ																																
STORIES	2	1.00																																
% HEATED	100	1.00																																
% AIR COND	0	1.00																																
% SPRINKLER	0	1.00																																
<table border="1"> <thead> <tr> <th>EFF. YR/AGE</th> <td colspan="2">1980 / 41</td> </tr> </thead> <tbody> <tr> <td>COND</td> <td>32</td> <td>32 %</td> </tr> <tr> <td>FUNC</td> <td>0</td> <td></td> </tr> <tr> <td>ECON</td> <td>0</td> <td></td> </tr> <tr> <td>DEPR</td> <td>32</td> <td>% GD 68</td> </tr> <tr> <td>RCNLD</td> <td colspan="2">\$441,700</td> </tr> </tbody> </table>																	EFF. YR/AGE	1980 / 41		COND	32	32 %	FUNC	0		ECON	0		DEPR	32	% GD 68	RCNLD	\$441,700	
EFF. YR/AGE	1980 / 41																																	
COND	32	32 %																																
FUNC	0																																	
ECON	0																																	
DEPR	32	% GD 68																																
RCNLD	\$441,700																																	