

Key: 2784

Town of E. BRIDGEWATER - Fiscal Year 2023

12/6/2022 6:38 pm SEQ #: 2.382

LEGAL

CURRENT OWNER				PARCEL ID				LOCATION			
HEGER GREGG C MYJESDI REALTY TRUST 318 WEST UNION ST E BRIDGEWATER, MA 02333				63-2-0				358 W UNION ST			
TRANSFER HISTORY				DOS	T	SALE PRICE	BK-PG (Cert)				
HEGER GREGG C				12/17/2004	A	100	29684-348				
HEGER GREGG C &				12/19/2003	A	100	27261-058				
HEGER GREGG C				03/13/2003	A	100	24473-183				

CLASS	CLASS%	DESCRIPTION			BN ID	BN	CARD	
1040	100	TWO FAMILY				1	1 of 1	
PMT NO	PMT DT	TY	DESC	AMOUNT	INSP	BY	1st	%
3510	02/26/2018	4	DEMO		05/02/2018	SLB	100	100
		6	CYCL GROWTH		07/28/2014	PW	0	0
		6	CYCL GROWTH		07/09/2014	LF	0	0

LAND

CD	T	AC/SF/UN	Ngh	Inf1	Inf2	ADJ BASE	SAF	Inf3	Lpi	VC	CREDIT AMT	ADJ VALUE
100	S	43,560	3	1.00	100	1.00	100	1.00	188,000	1.00	100	1.00
300	A	0.140	3	1.00	100	1.00	100	1.00	5,700	1.00	100	1.00
											ELP	1.00
												800

TOTAL	1.140 Acres	ZONING	RES 3	FRNT	0	ASSESSED	CURRENT	PREVIOUS
Ngh	RES 3	NOTE	LAND	188,800	171,700			
Inf1	FACTOR 100		BUILDING	180,400	178,600			
Inf2	PHY 100		DETACHED	0	0			
			OTHER	0	0			
		<b>TOTAL</b>		<b>369,200</b>	<b>350,300</b>			

DETACHED

TY	QUAL	COND	DIM/NOTE	YB	UNITS	ADJ PRICE	RCNLD	PHOTO	05/02/2018
									

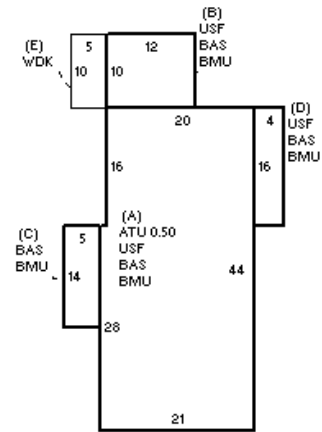

BUILDING

BUILDING	CD	ADJ	DESC	MEASURE	7/28/2014	PW
MODEL	1		RESIDENTIAL	LIST REVIEW	4/4/2013	ER
STYLE	7	0.90	CONVENTIONAL [100%]			
QUALITY	A	1.00	AVERAGE [100%]			
FRAME	1	1.00	WOOD FRAME [100%]			

BLDG COMMENTS  
2014 rents TAW 950 first floor TAW 900 second floor

G

YEAR BLT	1860	SIZE ADJ	1.000	ELEMENT	CD	DESCRIPTION	ADJ	S	BAT	T	DESCRIPTION	UNITS	YB	ADJ PRICE	RCN	TOTAL RCN	410,032		
NET AREA	2,254	DETAIL ADJ	1.009	FOUNDATION	5	BRICK/STONE	1.00	+	BMU	N	BSMT UNFINISHED	1,162		37.30	43,346	CONDITION ELEM CD			
\$NLA(RCN)	\$182	OVERALL	1.000	EXT COVER	4	VINYL	1.00	+	BAS	L	BASE AREA	1,162	1860	161.18	187,290	EXTERIOR			
				ROOF SHAPE	1	GABLE	1.00	+	USF	L	UPPER STORY FIN	1,092	1860	146.47	159,943	INTERIOR			
				ROOF COVER	1	ASPH SHINGLES	1.00	A	ATU	N	ATTIC UNF	454		30.30	13,756	KITCHEN			
				FLOOR COVER	99	N/A	1.00	E	WDK	N	WOOD DECK	50		31.60	1,580	BATHS			
				INT FINISH	99	N/A	1.00										HEAT		
				HEATING/COOLING	2	HOT WATER	1.02										ELECT		
				FUEL SOURCE	2	GAS	1.00										EFF.YR/AGE		1955 / 66
				ARPUD	0		1.00										COND		56 56 %
				AFFORDABLE	0		1.00										FUNC		0
													ECON		0				
													DEPR		56 % GD	44			
													RCNLD		\$180,400				