

Key: 2848

Town of E. BRIDGEWATER - Fiscal Year 2023

12/6/2022 6:38 pm SEQ #: 2.441

LEGAL

LAND

DETACHED

BUILDING

CURRENT OWNER				PARCEL ID				LOCATION			
MAHER-HARRISON PATRICIA 297 N CENTRAL ST E BRIDGEWATER, MA 02333				63-74-0				297 N CENTRAL ST			
TRANSFER HISTORY				DOS	T	SALE PRICE	BK-PG (Cert)				
MAHER-HARRISON PATRICIA				12/14/2010	A	1	39403-75				
HARRISON TIMOTHY H &				07/23/1992	J	4,166	11137-299				
HARRISON TIMOTHY H & PATR				06/04/1992	J	150,000	11023-331-33				

CLASS	CLASS%	DESCRIPTION			BN ID	BN	CARD	
1010	100	SINGLE FAMILY				1	1 of 1	
PMT NO	PMT DT	TY	DESC	AMOUNT	INSP	BY	1st	%
76	06/23/2003	6	CYCL GROWTH ALTERATIONS	5,000	07/03/2013		0	0

CD	T	AC/SF/UN	Ngh	Infl1	Infl2	ADJ BASE	SAF	Infl3	Lpi	VC	CREDIT AMT	ADJ VALUE
100	S	43,560	3	1.00	100	188,000	1.00	100	1.00	3	1.00	188,000
300	A	0.070	3	1.00	100	5,700	1.00	100	1.00	ELP	1.00	400

TOTAL	1.070 Acres	ZONING	NOTED	FRNT	0	ASSESSED	CURRENT	PREVIOUS
Ngh	RES 3					LAND	188,400	171,400
Infl1	FACTOR 100					BUILDING	229,800	206,300
Infl2	PHY 100					DETACHED	25,800	24,600
						OTHER	0	0
						TOTAL	444,000	402,300

TY	QUAL	COND	DIM/NOTE	YB	UNITS	ADJ PRICE	RCNLD
DGF	-	0.90	20 0.80		720	44.76	25,800



BUILDING	CD	ADJ	DESC	MEASURE	7/3/2013	LF
MODEL	1		RESIDENTIAL			
STYLE	5	0.95	COLONIAL [100%]	LIST		
QUALITY	A	1.00	AVERAGE [100%]	REVIEW	4/4/2013	ER
FRAME	1	1.00	WOOD FRAME [100%]			

BLDG COMMENTS	
---------------	--

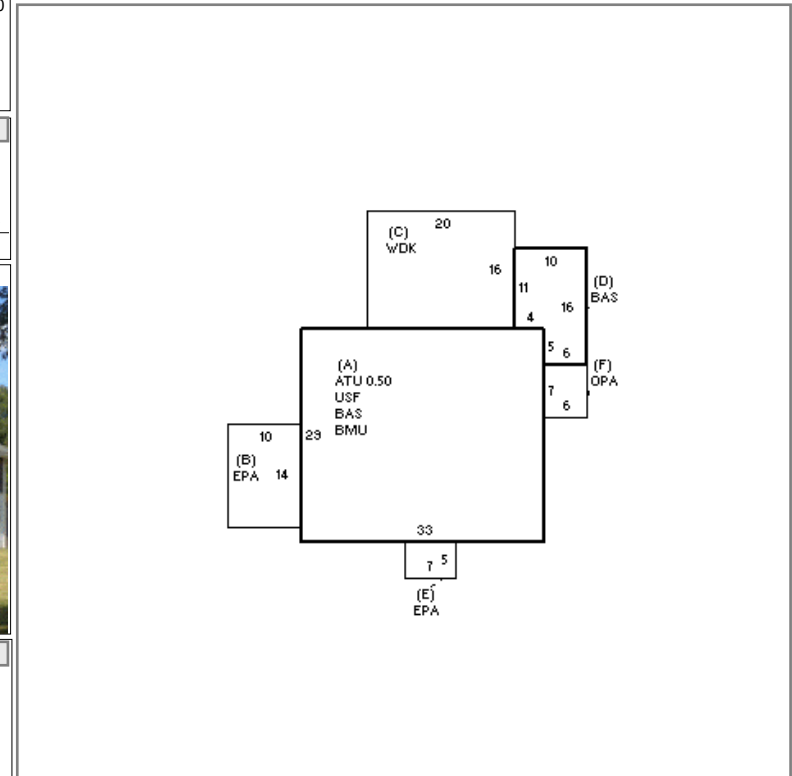

YEAR BLT	1927	SIZE ADJ	1.000	ELEMENT	CD	DESCRIPTION	ADJ	S	BAT	T	DESCRIPTION	UNITS	YB	ADJ PRICE	RCN	TOTAL RCN	403,226
NET AREA	2,054	DETAIL ADJ	0.969	FOUNDATION	5	BRICK/STONE	1.00	A	BMU	N	BSMT UNFINISHED	957		39.35	37,658	CONDITION ELEM	CD
\$NLA(RCN)	\$196	OVERALL	1.000	EXT COVER	1	WD SHINGLES	1.00	A	USF	L	UPPER STORY FIN	957	1927	144.80	138,576	EXTERIOR	
				ROOF SHAPE	1	GABLE	1.00	A	ATU	N	ATTIC UNF	479		30.30	14,514	INTERIOR	
				ROOF COVER	1	ASPH SHINGLES	1.00	+	EPA	N	ENCLOSED PORCH	175		74.40	13,020	KITCHEN	
				FLOOR COVER	99	N/A	1.00	C	WDK	N	WOOD DECK	320		31.60	10,112	BATHS	
				INT FINISH	99	N/A	1.00	+	BAS	L	BASE AREA	1,097	1927	159.35	174,804	HEAT	
				HEATING/COOLING	2	HOT WATER	1.02	F	OPA	N	OPEN PORCH	42		42.69	1,793	ELECT	
				FUEL SOURCE	99	N/A	1.00	F21	O	FPL 2S 1OP	1		6,819.00	6,819			
				ARPUD	0		1.00										
				AFFORDABLE	0		1.00										

EFF.YR/AGE	1963 / 58
COND	43 43 %
FUNC	0
ECON	0
DEPR	43 % GD 57
RCNLD	\$229,800