

Key: 2970

Town of E. BRIDGEWATER - Fiscal Year 2023

12/6/2022 6:38 pm SEQ #: 2.542

LEG
AL
LAND

CURRENT OWNER				PARCEL ID				LOCATION			
TOKARZ MICHAEL E & PATRICIA E 30 COUNTRY FARM RD E BRIDGEWATER, MA 02333				66-34-0				30 COUNTRY FARM RD			
TRANSFER HISTORY				DOS	T	SALE PRICE	BK-PG (Cert)				
TOKARZ MICHAEL E & PATRIC NPG DEVELOPMENT CO INC				01/19/1988	QS	234,000	8244-109				
				09/09/1987	QS		7989-049				

CLASS	CLASS%	DESCRIPTION			BN ID	BN	CARD	
1010	100	SINGLE FAMILY				1	1 of 1	
PMT NO	PMT DT	TY	DESC	AMOUNT	INSP	BY	1st	%
BP-19-354	09/23/2019	3	ALTERATIONS	1,466				0
		6	CYCL GROWTH		02/01/2013	LFF		0
1994A	02/05/2001	1	NEW CONST	67,000	08/05/2002	SLB	100	0

CD	T	AC/SF/UN	Ngh	Inf1	Inf2	ADJ BASE	SAF	Inf3	Lpi	VC	CREDIT AMT	ADJ VALUE
100	S	42,792	5	1.00	100	1.00	100	1.00	5	1.20		224,810

TOTAL	42,776 SF	ZONING	FRNT	0	ASSESSED	CURRENT	PREVIOUS
Ngh	RES 5	N O T E	LOT 3 & 3A/ C/W LOT 41		LAND	224,800	196,000
Inf1	FACTOR 100		BUILDING	439,300	392,900		
Inf2	PHY 100		DETACHED	11,300	10,700		
			OTHER	0	0		
TOTAL					675,400	599,600	

TY	QUAL	COND	DIM/NOTE	YB	UNITS	ADJ PRICE	RCNLD
SHF	A	1.00	40 0.60	1990	200	20.44	2,500
IPV	A	1.00	30 0.70	1994	648	19.48	8,800

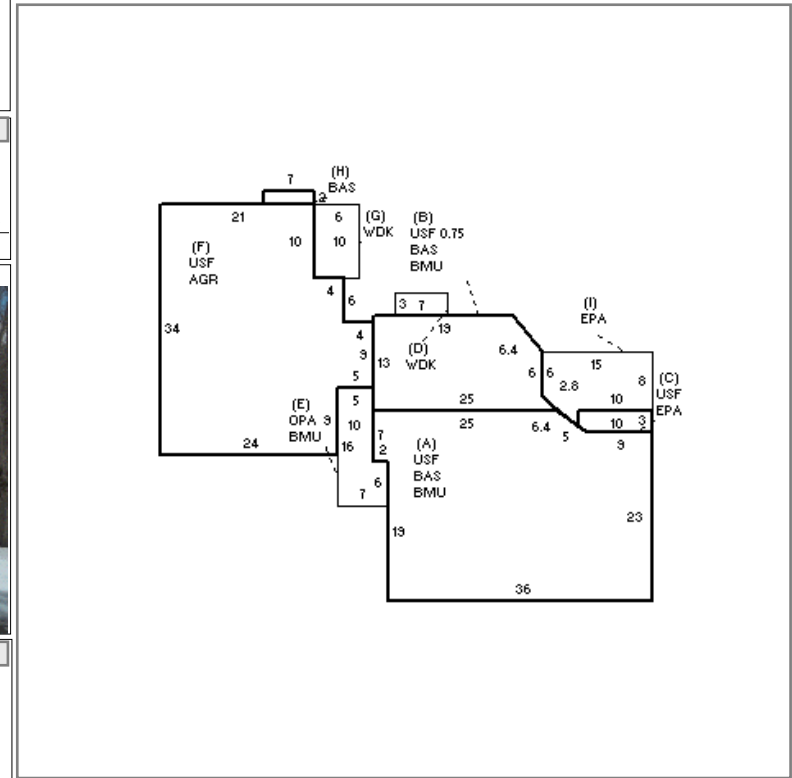

BUILDING	CD	ADJ	DESC	MEASURE	2/1/2013	LFF
MODEL	1		RESIDENTIAL	LIST		
STYLE	5	0.95	COLONIAL [100%]	REVIEW	4/5/2013	ER
QUALITY	+	1.05	AVG +/GOOD - [100%]			
FRAME	1	1.00	WOOD FRAME [100%]			

BLDG COMMENTS

DET
ACHED

B
U
I
L
D
I
N
G

YEAR BLT	1987	SIZE ADJ	1.000	ELEMENT	CD	DESCRIPTION	ADJ	S	BAT	T	DESCRIPTION	UNITS	YB	ADJ PRICE	RCN	TOTAL RCN	585,788																						
NET AREA	3,224	DETAIL ADJ	0.969	FOUNDATION	4	CONT BSMT WALL	1.00	+	BMU	N	BSMT UNFINISHED	1,300		38.11	49,544																								
\$NLA(RCN)	\$182	OVERALL	1.000	EXT COVER	2	CLAPBOARD	1.00	+	USF	L	UPPER STORY FIN	2,002	1987	134.33	268,921																								
				ROOF SHAPE	1	GABLE	1.00	+	EPA	N	ENCLOSED PORCH	150		78.12	11,718																								
				ROOF COVER	1	ASPH SHINGLES	1.00	+	WDK	N	WOOD DECK	81		33.19	2,688																								
				FLOOR COVER	99	N/A	1.00	E	OPA	N	OPEN PORCH	92		44.83	4,124																								
				INT FINISH	99	N/A	1.00	F	AGR	N	ATT GARAGE	837		66.27	55,464																								
				HEATING/COOLING	2	HOT WATER	1.02	+	BAS	L	BASE AREA	1,222	1987	147.82	180,634																								
				FUEL SOURCE	99	N/A	1.00		F21	O	FPL 2S 1OP	1		7,160.00	7,160																								
				ARPUD	0		1.00																																
				AFFORDABLE	0		1.00																																
<table border="1"> <thead> <tr> <th>CAPACITY</th> <th>UNITS</th> <th>ADJ</th> </tr> </thead> <tbody> <tr> <td>STORIES</td> <td>2</td> <td>1.00</td> </tr> <tr> <td>ROOMS</td> <td>8</td> <td>1.00</td> </tr> <tr> <td>BEDROOMS</td> <td>4</td> <td>1.00</td> </tr> <tr> <td>BATHROOMS</td> <td>2</td> <td>1.00</td> </tr> <tr> <td># 1/2 BATHS</td> <td>1</td> <td>1.00</td> </tr> <tr> <td>TOT FIXTURES</td> <td>8</td> <td>\$5,535</td> </tr> <tr> <td># UNITS</td> <td>1</td> <td>1.00</td> </tr> </tbody> </table>																CAPACITY	UNITS	ADJ	STORIES	2	1.00	ROOMS	8	1.00	BEDROOMS	4	1.00	BATHROOMS	2	1.00	# 1/2 BATHS	1	1.00	TOT FIXTURES	8	\$5,535	# UNITS	1	1.00
CAPACITY	UNITS	ADJ																																					
STORIES	2	1.00																																					
ROOMS	8	1.00																																					
BEDROOMS	4	1.00																																					
BATHROOMS	2	1.00																																					
# 1/2 BATHS	1	1.00																																					
TOT FIXTURES	8	\$5,535																																					
# UNITS	1	1.00																																					
<table border="1"> <thead> <tr> <th>CONDITION ELEM</th> <th>CD</th> </tr> </thead> <tbody> <tr> <td>EXTERIOR</td> <td></td> </tr> <tr> <td>INTERIOR</td> <td></td> </tr> <tr> <td>KITCHEN</td> <td></td> </tr> <tr> <td>BATHS</td> <td></td> </tr> <tr> <td>HEAT</td> <td></td> </tr> <tr> <td>ELECT</td> <td></td> </tr> </tbody> </table>																CONDITION ELEM	CD	EXTERIOR		INTERIOR		KITCHEN		BATHS		HEAT		ELECT											
CONDITION ELEM	CD																																						
EXTERIOR																																							
INTERIOR																																							
KITCHEN																																							
BATHS																																							
HEAT																																							
ELECT																																							
<table border="1"> <thead> <tr> <th>EFF.YR/AGE</th> <td colspan="2">1989 / 32</td> </tr> </thead> <tbody> <tr> <td>COND</td> <td>25</td> <td>25 %</td> </tr> <tr> <td>FUNC</td> <td>0</td> <td></td> </tr> <tr> <td>ECON</td> <td>0</td> <td></td> </tr> <tr> <td>DEPR</td> <td>25</td> <td>% GD 75</td> </tr> </tbody> </table>																EFF.YR/AGE	1989 / 32		COND	25	25 %	FUNC	0		ECON	0		DEPR	25	% GD 75									
EFF.YR/AGE	1989 / 32																																						
COND	25	25 %																																					
FUNC	0																																						
ECON	0																																						
DEPR	25	% GD 75																																					
<table border="1"> <thead> <tr> <th>RCNLD</th> <td>\$439,300</td> </tr> </thead> </table>																RCNLD	\$439,300																						
RCNLD	\$439,300																																						