

Key: 3230

Town of E. BRIDGEWATER - Fiscal Year 2023

12/6/2022 6:38 pm SEQ #: 2.763

LEGALS

CURRENT OWNER				PARCEL ID				LOCATION			
KENNEALLY JOELLEN D JOELLEN D KENNEALLY REVOC TR 6 EVERGREEN WAY E BRIDGEWATER, MA 02333				72-5-0				6 EVERGREEN WAY			
TRANSFER HISTORY				DOS	T	SALE PRICE	BK-PG (Cert)				
KENNEALLY JOELLEN D				06/19/2012	A	1	41530-042				
KENNEALLY JOELLEN				04/08/2008	H	1	35827-086				
COOTS JOELLEN D & PAUL E				05/25/1990	A	100	9768-306				

CLASS	CLASS%	DESCRIPTION			BN ID	BN	CARD	
1010	100	SINGLE FAMILY				1	1 of 1	
PMT NO	PMT DT	TY	DESC	AMOUNT	INSP	BY	1st	%
		6	CYCL GROWTH		03/11/2013	PW	0	0

LAND

CD	T	AC/SF/UN	Ngh	Inf1	Inf2	ADJ BASE	SAF	Inf3	Lpi	VC	CREDIT AMT	ADJ VALUE
100	S	43,560	4	1.00	100	1.00	100	1.00	4	1.20		225,600
300	A	0.360	4	1.00	100	1.00	100	1.00	ELP	1.00		2,050

DETACHED

TOTAL	1.360 Acres		ZONING	FRNT	0	ASSESSED	CURRENT	PREVIOUS
Ngh	RES 4		N O T E	PLAN 90-361		LAND	227,700	190,000
Inf1	FACTOR 100			BUILDING	284,300	261,600		
Inf2	PHY 100			DETACHED	2,500	2,300		
				OTHER	0	0		
				TOTAL		514,500	453,900	

TY	QUAL	COND	DIM/NOTE	YB	UNITS	ADJ PRICE	RCNLD	PHOTO
SHF	A	1.00	40 0.60		200	20.44	2,500	03/11/2013

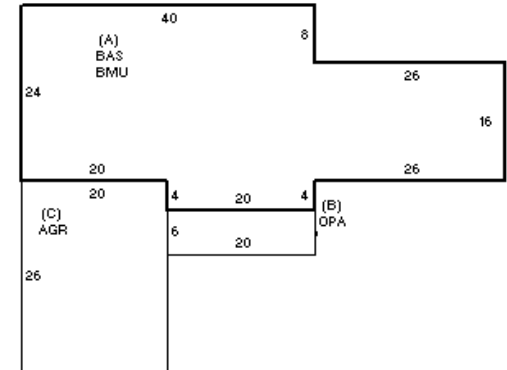

BUILDING

BUILDING	CD	ADJ	DESC	MEASURE	3/11/2013	PW
MODEL	1		RESIDENTIAL	LIST		
STYLE	1	1.00	RANCH [100%]	REVIEW	4/8/2013	ER
QUALITY	A	1.00	AVERAGE [100%]			
FRAME	1	1.00	WOOD FRAME [100%]			

BLDG COMMENTS

INDING

YEAR BLT	1990	SIZE ADJ	1.000	ELEMENT	CD	DESCRIPTION	ADJ	S	BAT	T	DESCRIPTION	UNITS	YB	ADJ PRICE	RCN	TOTAL RCN	374,030																						
NET AREA	1,456	DETAIL ADJ	1.000	FOUNDATION	4	CONT BSMT WALL	1.00	A	BMU	N	BSMT UNFINISHED	1,456		35.39	51,534																								
\$NLA(RCN)	\$257	OVERALL	1.000	EXT COVER	2	CLAPBOARD	1.00	A	BAS	L	BASE AREA	1,456	1990	186.22	271,136																								
				ROOF SHAPE	1	GABLE	1.00	B	OPA	N	OPEN PORCH	120		42.70	5,124																								
				ROOF COVER	1	ASPH SHINGLES	1.00	C	AGR	N	ATT GARAGE	520		69.50	36,139																								
				FLOOR COVER	99	N/A	1.00	F11	O	O	FPL 1S 1OP	1		6,017.00	6,017																								
				INT FINISH	99	N/A	1.00																																
				HEATING/COOLING	1	FORCED AIR	1.00																																
				FUEL SOURCE	99	N/A	1.00																																
				ARPUD	0		1.00																																
				AFFORDABLE	0		1.00																																
<table border="1"> <thead> <tr> <th>CAPACITY</th> <th>UNITS</th> <th>ADJ</th> </tr> </thead> <tbody> <tr> <td>STORIES</td> <td>1</td> <td>1.00</td> </tr> <tr> <td>ROOMS</td> <td>5</td> <td>1.00</td> </tr> <tr> <td>BEDROOMS</td> <td>3</td> <td>1.00</td> </tr> <tr> <td>BATHROOMS</td> <td>2</td> <td>1.00</td> </tr> <tr> <td># 1/2 BATHS</td> <td>0</td> <td>1.00</td> </tr> <tr> <td>TOT FIXTURES</td> <td>6</td> <td>\$4,080</td> </tr> <tr> <td># UNITS</td> <td>1</td> <td>1.00</td> </tr> </tbody> </table>																CAPACITY	UNITS	ADJ	STORIES	1	1.00	ROOMS	5	1.00	BEDROOMS	3	1.00	BATHROOMS	2	1.00	# 1/2 BATHS	0	1.00	TOT FIXTURES	6	\$4,080	# UNITS	1	1.00
CAPACITY	UNITS	ADJ																																					
STORIES	1	1.00																																					
ROOMS	5	1.00																																					
BEDROOMS	3	1.00																																					
BATHROOMS	2	1.00																																					
# 1/2 BATHS	0	1.00																																					
TOT FIXTURES	6	\$4,080																																					
# UNITS	1	1.00																																					
<table border="1"> <thead> <tr> <th>CONDITION ELEM</th> <th>CD</th> </tr> </thead> <tbody> <tr> <td>EXTERIOR</td> <td></td> </tr> <tr> <td>INTERIOR</td> <td></td> </tr> <tr> <td>KITCHEN</td> <td></td> </tr> <tr> <td>BATHS</td> <td></td> </tr> <tr> <td>HEAT</td> <td></td> </tr> <tr> <td>ELECT</td> <td></td> </tr> </tbody> </table>																CONDITION ELEM	CD	EXTERIOR		INTERIOR		KITCHEN		BATHS		HEAT		ELECT											
CONDITION ELEM	CD																																						
EXTERIOR																																							
INTERIOR																																							
KITCHEN																																							
BATHS																																							
HEAT																																							
ELECT																																							
<table border="1"> <thead> <tr> <th>EFF.YR/AGE</th> <td colspan="2">1990 / 31</td> </tr> </thead> <tbody> <tr> <td>COND</td> <td>24</td> <td>24 %</td> </tr> <tr> <td>FUNC</td> <td>0</td> <td></td> </tr> <tr> <td>ECON</td> <td>0</td> <td></td> </tr> <tr> <td>DEPR</td> <td>24</td> <td>% GD 76</td> </tr> </tbody> </table>																EFF.YR/AGE	1990 / 31		COND	24	24 %	FUNC	0		ECON	0		DEPR	24	% GD 76									
EFF.YR/AGE	1990 / 31																																						
COND	24	24 %																																					
FUNC	0																																						
ECON	0																																						
DEPR	24	% GD 76																																					
<table border="1"> <thead> <tr> <th>RCNLD</th> <td>\$284,300</td> </tr> </thead> </table>																RCNLD	\$284,300																						
RCNLD	\$284,300																																						