

Key: 3282

Town of E. BRIDGEWATER - Fiscal Year 2023

12/6/2022 6:38 pm SEQ #: 2.814

LEGAL

CURRENT OWNER				PARCEL ID				LOCATION			
ABRAMS ROY & NANCY J 168 ELM ST E BRIDGEWATER, MA 02333				72-58-0				168 ELM ST			
TRANSFER HISTORY				DOS	T	SALE PRICE		BK-PG (Cert)			
ABRAMS ROY & NANCY J				12/04/1975	QS			4120-739			

CLASS	CLASS%	DESCRIPTION			BN ID	BN	CARD	
1010	100	SINGLE FAMILY				1	1 of 1	
PMT NO	PMT DT	TY	DESC	AMOUNT	INSP	BY	1st	%
BP-18-345	12/12/2018	3	ALTERATIONS	5,633				0
		6	CYCL GROWTH		05/07/2014	LF		0

LAND

CD	T	AC/SF/UN	Ngh	Infl1	Infl2	ADJ BASE	SAF	Infl3	Lpi	VC	CREDIT AMT	ADJ VALUE
100	S	37,930 3	1.00	100	1.00	188,000	1.12	100	1.00	3	1.00	183,130

TOTAL	37,930 SF	ZONING	FRNT	0	ASSESSED	CURRENT	PREVIOUS
Ngh	RES 3	NOTE LOT 4/ T 11424			LAND	183,100	166,600
Infl1	FACTOR 100		BUILDING	250,500	228,500		
Infl2	PHY 100		DETACHED	0	0		
			OTHER	0	0		
TOTAL					433,600	395,100	

DETACHED

TY	QUAL	COND	DIM/NOTE	YB	UNITS	ADJ PRICE	RCNLD	PHOTO
								05/07/2014

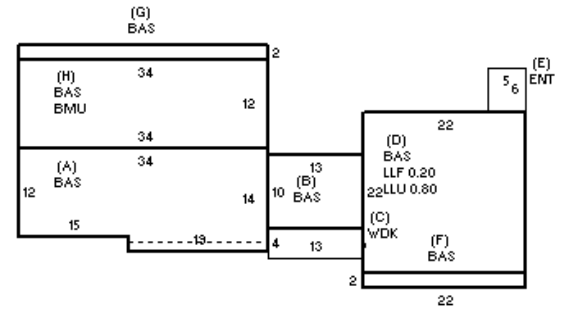

BUILDING

BUILDING	CD	ADJ	DESC	MEASURE	5/7/2014	LF
MODEL	1		RESIDENTIAL	LIST		
STYLE	3	1.05	SPLIT LEVEL [100%]	REVIEW	4/9/2013	ER
QUALITY	A	1.00	AVERAGE [100%]			
FRAME	1	1.00	WOOD FRAME [100%]			

BLDG COMMENTS

G

YEAR BLT	1962	SIZE ADJ	1.000	ELEMENT	CD	DESCRIPTION	ADJ	S	BAT	T	DESCRIPTION	UNITS	YB	ADJ PRICE	RCN	TOTAL RCN	343,124
NET AREA	1,580	DETAIL ADJ	1.050	FOUNDATION	4	CONT BSMT WALL	1.00	+	BAS	L	BASE AREA	1,580	1962	172.30	272,236		
\$NLA(RCN)	\$217	OVERALL	1.000	EXT COVER	1	WD SHINGLES	1.00	C	WDK	N	WOOD DECK	52		31.60	1,643		
				ROOF SHAPE	1	GABLE	1.00	D	LLU	N	LOWER LEVEL UNF	387		63.70	24,651		
				ROOF COVER	1	ASPH SHINGLES	1.00	D	LLF	N	LOWER LEVEL FIN	97		123.34	11,964		
				FLOOR COVER	99	N/A	1.00	E	ENT	N	ENCLOSED ENTRY	30		81.10	2,433		
				INT FINISH	99	N/A	1.00	H	BMU	N	BSMT UNFINISHED	408		52.05	21,236		
				HEATING/COOLING	1	FORCED AIR	1.00	F21	O		FPL 2S 10P	1		6,819.00	6,819		
				FUEL SOURCE	99	N/A	1.00										
				ARPUD	0		1.00										
				AFFORDABLE	0		1.00										
																CONDITION ELEM	CD
																EXTERIOR	
																INTERIOR	
																KITCHEN	
																BATHS	
																HEAT	
																ELECT	
																EFF.YR/AGE	1980 / 41
																COND	27 27 %
																FUNC	0
																ECON	0
																DEPR	27 % GD 73
																RCNLD	\$250,500