

Key: 3321

Town of E. BRIDGEWATER - Fiscal Year 2023

12/6/2022 6:38 pm SEQ #: 2.850

LEG
AL
LAND

CURRENT OWNER				PARCEL ID				LOCATION			
WARD DONNA L & PAUL W 114 PLEASANT AVENUE E BRIDGEWATER, MA 02333				73-32-0				114 PLEASANT AV			
TRANSFER HISTORY				DOS	T	SALE PRICE	BK-PG (Cert)				
WARD DONNA L & PAUL W				06/20/2006	A		1 32893-134				
SETTERLAND DONALD W				10/26/1949	QS		2072-573				

CLASS	CLASS%	DESCRIPTION			BN ID	BN	CARD	
1010	100	SINGLE FAMILY				1	1 of 1	
PMT NO	PMT DT	TY	DESC	AMOUNT	INSP	BY	1st	%
309		51	FIELD REVIEW		09/17/2013	LF	0	0
252	10/18/2005	2	ADDITIONS	25,000			100	100
550	08/31/2005	7	DETACHED BLD				100	100
	05/24/2004	3	ALTERATIONS	10,000			100	100
458	04/15/2004	2	ADDITIONS	65,000			100	100

CD	T	AC/SF/UN	Ngh	Inf1	Inf2	ADJ BASE	SAF	Inf3	Lpi	VC	CREDIT AMT	ADJ VALUE
100	S	43,560 3	1.00	100	1.00	188,000	1.00	100	1.00	3	1.00	188,000
300	A	0.770 3	1.00	100	1.00	5,700	1.00	100	1.00	ELP	1.00	4,390

TOTAL	1.770 Acres	ZONING	FRNT	0	ASSESSED	CURRENT	PREVIOUS
Ngh	RES 3	N O T E	T 3788/ C/W 33		LAND	192,400	175,000
Inf1	FACTOR 100		LAND	293,300	256,800		
Inf2	PHY 100		DETACHED	19,300	18,300		
			OTHER	0	0		
			TOTAL	505,000	450,100		

TY	QUAL	COND	DIM/NOTE	YB	UNITS	ADJ PRICE	RCNLD
DGF	-	0.90 30	0.70		352	52.42	12,900
SHF	A	1.00 40	0.60	2005	200	20.44	2,500
GZB	A	1.00 50	0.50		300	25.76	3,900

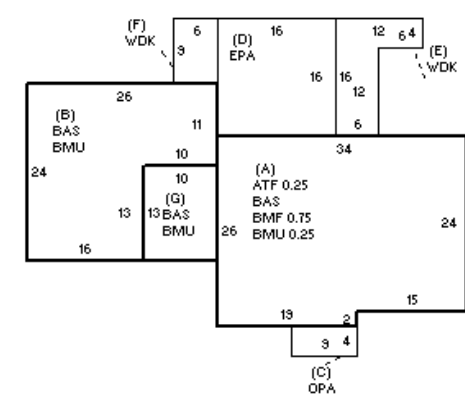
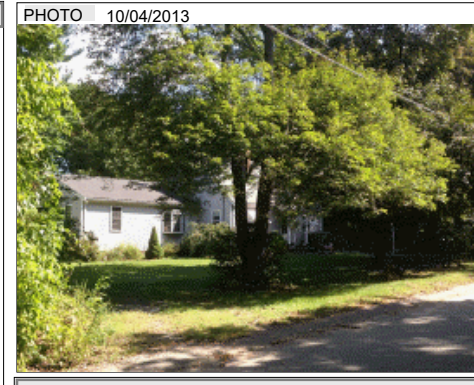

BUILDING	CD	ADJ	DESC	MEASURE	9/17/2013	LF
MODEL	1		RESIDENTIAL	LIST		
STYLE	4	1.00	CAPE [100%]	REVIEW	4/9/2013	ER
QUALITY	A	1.00	AVERAGE [100%]			
FRAME	1	1.00	WOOD FRAME [100%]			

BLDG COMMENTS

DET
ACH
ED

B
U
I
L
D
I
N
G

YEAR BLT	1950	SIZE ADJ	1.000	ELEMENT	CD	DESCRIPTION	ADJ	S	BAT	T	DESCRIPTION	UNITS	YB	ADJ PRICE	RCN	TOTAL RCN	391,070		
NET AREA	1,692	DETAIL ADJ	1.030	FOUNDATION	4	CONT BSMT WALL	1.00	+	BMU	N	BSMT UNFINISHED	838		35.26	29,544	CONDITION ELEM	CD		
\$NLA(RCN)	\$231	OVERALL	1.000	EXT COVER	4	VINYL	1.00	A	BMF	N	BSMT FINISH-SEP	641		49.58	31,781	EXTERIOR			
				ROOF SHAPE	1	GABLE	1.00	+	BAS	L	BASE AREA	984	1950	181.04	178,144	INTERIOR			
				ROOF COVER	1	ASPH SHINGLES	1.00	A	ATF	L	ATTIC FINISH	214	1950	117.13	25,065	KITCHEN			
				FLOOR COVER	99	N/A	1.00	B	BAS	L	BASE AREA	494	2004	181.04	89,434	BATHS			
				INT FINISH	99	N/A	1.00	C	OPA	N	OPEN PORCH	36		42.69	1,537	HEAT			
				HEATING/COOLING	9	WARM/COOL AIR	1.03	D	EPA	N	ENCLOSED PORCH	256		74.40	19,046	ELECT			
				FUEL SOURCE	2	GAS	1.00	+	WDK	N	WOOD DECK	174		31.60	5,498				
				ARPUD	0		1.00		F21	O	FPL 2S 1OP	1		6,819.00	6,819				
				AFFORDABLE	0		1.00												
																		EFF.YR/AGE	1989 / 32
																		COND	25 25 %
																		FUNC	0
																		ECON	0
																		DEPR	25 % GD 75
																		RCNLD	\$293,300