

Key: 3345

Town of E. BRIDGEWATER - Fiscal Year 2023

12/6/2022 6:38 pm SEQ #: 2.871

LEGAL

CURRENT OWNER				PARCEL ID				LOCATION			
LANE HENRY C & CAROLE L LANE FAMILY REALTY TRUST 158 MATFIELD ST E. BRIDGEWATER, MA 02333				74-14-0				84 MATFIELD ST			
TRANSFER HISTORY				DOS	T	SALE PRICE	BK-PG (Cert)				
LANE HENRY C & CAROLE L				04/27/2004	A	100	28052-135				
LANE HENRY C & CAROLE L				11/29/1963	QS		3072-267				

CLASS	CLASS%	DESCRIPTION			BN ID	BN	CARD	
1010	100	SINGLE FAMILY				1	1 of 1	
PMT NO	PMT DT	TY	DESC	AMOUNT	INSP	BY	1st	%
22-338	07/25/2022	3	ALTERATIONS	6,168	12/02/2020	SD		0
		6	CYCL GROWTH		07/09/2014	LF		0
		6	CYCL GROWTH					0
1244	07/19/2012	3	ALTERATIONS	6,100	08/30/2005			0
		6	CYCL GROWTH					0

LAND

CD	T	AC/SF/UN	Ngh	Infl1	Infl2	ADJ BASE	SAF	Infl3	Lpi	VC	CREDIT AMT	ADJ VALUE
100	S	33,400 3	1.00	100	100	188,000	1.24	100	1.00	3	1.00	179,240

TOTAL	33,411 SF	ZONING	FRNT	0	ASSESSED	CURRENT	PREVIOUS
Ngh	RES 3	N O T E	T 7899		LAND	179,200	163,000
Infl1	FACTOR 100		BUILDING	161,800	161,500		
Infl2	PHY 100		DETACHED	26,500	25,300		
			OTHER	0	0		
TOTAL						367,500	349,800

DETAILED

TY	QUAL	COND	DIM/NOTE	YB	UNITS	ADJ PRICE	RCNLD
FBN	A	1.00 60 0.40			361	33.41	4,800
LBN	A	1.00 10 0.90			660	33.64	20,000
DDK	A	1.00 40 0.60			140	20.66	1,700

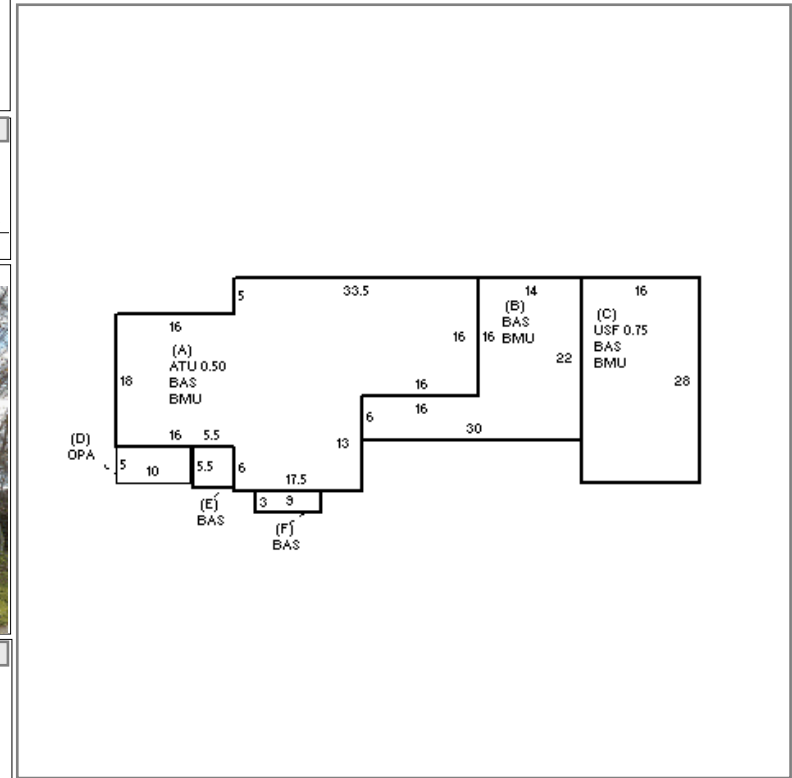

BUILDING

BUILDING	CD	ADJ	DESC	MEASURE	12/2/2020	SD
MODEL	1		RESIDENTIAL	LIST	12/2/2020	SD
STYLE	7	0.90	CONVENTIONAL [100%]	REVIEW	4/9/2013	ER
QUALITY	A	1.00	AVERAGE [100%]			
FRAME	1	1.00	WOOD FRAME [100%]			

BLDG COMMENTS

INDING

YEAR BLT	1860	SIZE ADJ	1.000	ELEMENT	CD	DESCRIPTION	ADJ	S	BAT	T	DESCRIPTION	UNITS	YB	ADJ PRICE	RCN	TOTAL RCN	449,439													
NET AREA	2,297	DETAIL ADJ	1.009	FOUNDATION	5	BRICK/STONE	1.00	+	BMU	N	BSMT UNFINISHED	1,904		33.59	63,955															
\$NLA(RCN)	\$196	OVERALL	1.000	EXT COVER	4	VINYL	1.00	A	ATU	N	ATTIC UNF	526		30.30	15,938															
				ROOF SHAPE	1	GABLE	1.00	C	USF	L	UPPER STORY FIN	336	1860	145.67	48,945															
				ROOF COVER	1	ASPH SHINGLES	1.00	D	OPA	N	OPEN PORCH	50		42.70	2,135															
				FLOOR COVER	99	N/A	1.00	+	BAS	L	BASE AREA	1,961	1860	160.30	314,349															
				INT FINISH	99	N/A	1.00																							
				HEATING/COOLING	2	HOT WATER	1.02																							
				FUEL SOURCE	99	N/A	1.00																							
				ARPUD	0		1.00																							
				AFFORDABLE	0		1.00																							
<table border="1"> <thead> <tr> <th>CONDITION ELEM</th> <th>CD</th> </tr> </thead> <tbody> <tr> <td>EXTERIOR</td> <td></td> </tr> <tr> <td>INTERIOR</td> <td></td> </tr> <tr> <td>KITCHEN</td> <td></td> </tr> <tr> <td>BATHS</td> <td></td> </tr> <tr> <td>HEAT</td> <td></td> </tr> <tr> <td>ELECT</td> <td></td> </tr> </tbody> </table>																CONDITION ELEM	CD	EXTERIOR		INTERIOR		KITCHEN		BATHS		HEAT		ELECT		
CONDITION ELEM	CD																													
EXTERIOR																														
INTERIOR																														
KITCHEN																														
BATHS																														
HEAT																														
ELECT																														
<table border="1"> <thead> <tr> <th>EFF. YR/AGE</th> <td colspan="2">1951 / 70</td> </tr> </thead> <tbody> <tr> <td>COND</td> <td>64</td> <td>64 %</td> </tr> <tr> <td>FUNC</td> <td>0</td> <td></td> </tr> <tr> <td>ECON</td> <td>0</td> <td></td> </tr> <tr> <td>DEPR</td> <td>64</td> <td>% GD 36</td> </tr> </tbody> </table>																EFF. YR/AGE	1951 / 70		COND	64	64 %	FUNC	0		ECON	0		DEPR	64	% GD 36
EFF. YR/AGE	1951 / 70																													
COND	64	64 %																												
FUNC	0																													
ECON	0																													
DEPR	64	% GD 36																												
<table border="1"> <thead> <tr> <th>RCNLD</th> <td>\$161,800</td> </tr> </thead> </table>																RCNLD	\$161,800													
RCNLD	\$161,800																													