

Key: 3346

Town of E. BRIDGEWATER - Fiscal Year 2023

12/6/2022 6:38 pm SEQ #: 2.872

LEG
A
L

L
A
N
D

CURRENT OWNER				PARCEL ID				LOCATION				
ROBINSON MICHAEL & STEPHANIE 29 WATERMAN ST E. BRIDGEWATER, MA 02333				74-15-0				29 WATERMAN ST				
TRANSFER HISTORY				DOS	T	SALE PRICE	BK-PG (Cert)					
ROBINSON MICHAEL & STEPHA				07/30/2002	QS	260,000	22525-032					
DANGELO MARK S & MICHELLE				07/06/1999	F	94,000	17638-207					
DANGELO MARK S & MICHELLE				07/05/1999	F	94,000	17638-207					
CD	T	AC/SF/UN	Ngh	Infl1	Infl2	ADJ BASE	SAF	Infl3	Lpi	VC	CREDIT AMT	ADJ VALUE
100	S	23,791	3	1.00	100	1.00	100	1.00	3	1.00		170,940

CLASS	CLASS%	DESCRIPTION			BN ID	BN	CARD	
1010	100	SINGLE FAMILY				1	1 of 1	
PMT NO	PMT DT	TY	DESC	AMOUNT	INSP	BY	1st	%
302	05/12/2008	6	CYCL GROWTH		09/12/2013	LF	0	0
		6	CYCL GROWTH		06/11/2008		0	0
		2	ADDITIONS	83,500	04/30/2009		0	0

TOTAL	23,784 SF	ZONING	FRNT	0	ASSESSED	CURRENT	PREVIOUS
Ngh	RES 3	NOTE			LAND	170,900	155,500
Infl1	FACTOR 100		BUILDING	207,300	199,200		
Infl2	PHY 100		DETACHED	0	0		
			OTHER	0	0		
					TOTAL	378,200	354,700

D
E
T
A
C
H
E
D

TY	QUAL	COND	DIM/NOTE	YB	UNITS	ADJ PRICE	RCNLD

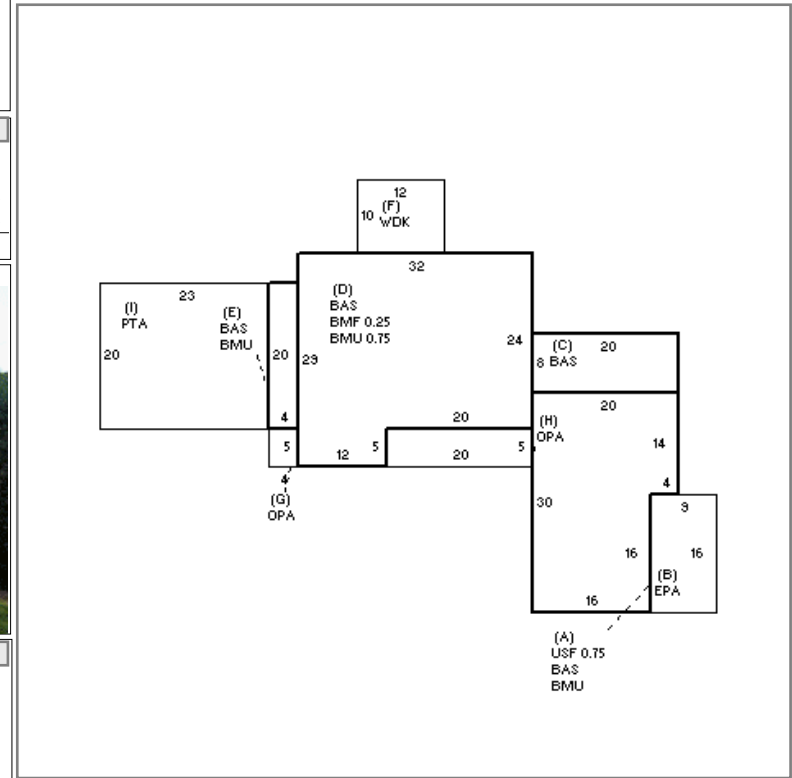

BUILDING	CD	ADJ	DESC	MEASURE	9/12/2013	LF
MODEL	1		RESIDENTIAL	LIST		
STYLE	7	0.90	CONVENTIONAL [100%]	REVIEW	4/9/2013	ER
QUALITY	A	1.00	AVERAGE [100%]			
FRAME	1	1.00	WOOD FRAME [100%]			

BLDG COMMENTS

B
U
I
L
D
I
N
G

YEAR BLT	1870	SIZE ADJ	1.000	ELEMENT	CD	DESCRIPTION	ADJ	S	BAT	T	DESCRIPTION	UNITS	YB	ADJ PRICE	RCN	TOTAL RCN	383,891																	
NET AREA	2,006	DETAIL ADJ	0.927	FOUNDATION	5	BRICK/STONE	1.00	+	BMU	N	BSMT UNFINISHED	1,237		35.46	43,868	CONDITION ELEM	CD																	
\$NLA(RCN)	\$191	OVERALL	1.000	EXT COVER	4	VINYL	1.00	A	USF	L	UPPER STORY FIN	402	1870	139.55	56,101	EXTERIOR																		
				ROOF SHAPE	1	GABLE	1.00	B	EPA	N	ENCLOSED PORCH	144		74.40	10,714	INTERIOR																		
				ROOF COVER	1	ASPH SHINGLES	1.00	+	BAS	L	BASE AREA	696	1870	153.57	106,885	KITCHEN																		
				FLOOR COVER	99	N/A	1.00	D	BMF	N	BSMT FINISH-SEP	207		49.87	10,324	BATHS																		
				INT FINISH	99	N/A	1.00	+	BAS	L	BASE AREA	908	2008	153.57	139,442	BATHS																		
				HEATING/COOLING	9	WARM/COOL AIR	1.03	F	WDK	N	WOOD DECK	120		31.60	3,792	HEAT																		
				FUEL SOURCE	2	GAS	1.00	+	OPA	N	OPEN PORCH	120		42.70	5,124	ELECT																		
				ARPUD	0		1.00	I	PTA	N	PATIO	460		12.50	5,750																			
				AFFORDABLE	0		1.00																											
<table border="1"> <thead> <tr> <th>EFF.YR/AGE</th> <td colspan="2">1960 / 61</td> </tr> </thead> <tbody> <tr> <td>COND</td> <td>46</td> <td>46 %</td> </tr> <tr> <td>FUNC</td> <td>0</td> <td></td> </tr> <tr> <td>ECON</td> <td>0</td> <td></td> </tr> <tr> <td>DEPR</td> <td>46</td> <td>% GD 54</td> </tr> <tr> <td>RCNLD</td> <td colspan="2">\$207,300</td> </tr> </tbody> </table>																	EFF.YR/AGE	1960 / 61		COND	46	46 %	FUNC	0		ECON	0		DEPR	46	% GD 54	RCNLD	\$207,300	
EFF.YR/AGE	1960 / 61																																	
COND	46	46 %																																
FUNC	0																																	
ECON	0																																	
DEPR	46	% GD 54																																
RCNLD	\$207,300																																	