

Key: 3413

Town of E. BRIDGEWATER - Fiscal Year 2023

12/6/2022 6:38 pm SEQ #: 2.930

LEGAL

LAND

DETACHED

BUILDING

CURRENT OWNER				PARCEL ID				LOCATION			
BERUBE HENRY W & CAROL A BOX 280 E BRIDGEWATER, MA 02333				76-34-0				1415 CENTRAL ST			
TRANSFER HISTORY				DOS	T	SALE PRICE	BK-PG (Cert)				
BERUBE HENRY W & CAROL A				11/04/1985	QS	120,900	6405-055				

CLASS	CLASS%	DESCRIPTION			BN ID	BN	CARD	
1010	100	SINGLE FAMILY				1	1 of 1	
PMT NO	PMT DT	TY	DESC	AMOUNT	INSP	BY	1st	%
60	05/05/2009	6	CYCL GROWTH		12/01/2020	SD	0	0
710	09/25/2006	3	ALTERATIONS	5,100	07/10/2013		0	0
		6	CYCL GROWTH		06/17/2009		0	0
		3	ALTERATIONS	1,500			0	0

CD	T	AC/SF/UN	Ngh	Inf1	Inf2	ADJ BASE	SAF	Inf3	Lpi	VC	CREDIT AMT	ADJ VALUE
100	S	35,000 3	1.00	100	1.00	188,000	1.20	100	1.00	3	1.00	180,620

TOTAL	35,000 SF	ZONING	FRNT	0	ASSESSED	CURRENT	PREVIOUS
Ngh	RES 3	NOTE LOT 1/ T 14203	LAND	180,600	164,300		
Inf1	FACTOR 100		BUILDING	268,400	236,200		
Inf2	PHY 100		DETACHED	2,500	2,300		
			OTHER	0	0		
			TOTAL	451,500	402,800		

TY	QUAL	COND	DIM/NOTE	YB	UNITS	ADJ PRICE	RCNLD
SHF	A	1.00 40 0.60			200	20.44	2,500

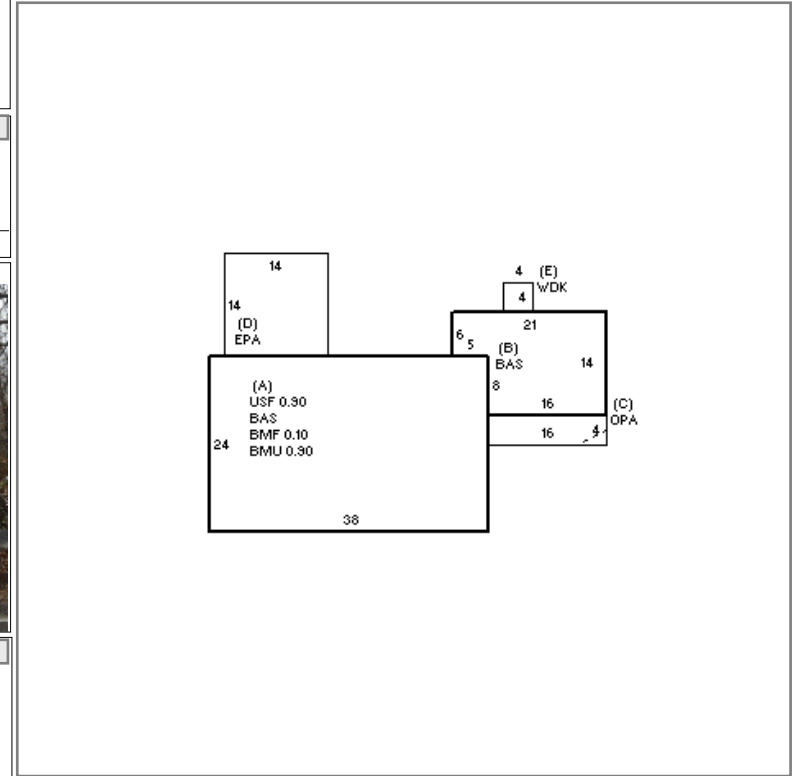

BUILDING	CD	ADJ	DESC	MEASURE	12/1/2020	SD
MODEL	1		RESIDENTIAL	LIST	12/1/2020	SD
STYLE	5	0.95	COLONIAL [100%]	REVIEW	4/9/2013	ER
QUALITY	A	1.00	AVERAGE [100%]			
FRAME	1	1.00	WOOD FRAME [100%]			

BLDG COMMENTS

YEAR BLT	1985	SIZE ADJ	1.000	ELEMENT	CD	DESCRIPTION	ADJ	S	BAT	T	DESCRIPTION	UNITS	YB	ADJ PRICE	RCN	TOTAL RCN	367,643
NET AREA	1,987	DETAIL ADJ	0.950	FOUNDATION	4	CONT BSMT WALL	1.00	A	BMU	N	BSMT UNFINISHED	821		39.94	32,790	CONDITION ELEM	CD
\$NLA(RCN)	\$185	OVERALL	1.000	EXT COVER	1	WD SHINGLES	1.00	A	BMF	N	BSMT FINISH-SEP	91		56.16	5,111	EXTERIOR	
				ROOF SHAPE	3	GAMBREL	1.00	A	USF	L	UPPER STORY FIN	821	1985	143.47	117,787	INTERIOR	
				ROOF COVER	1	ASPH SHINGLES	1.00	+	BAS	L	BASE AREA	1,166	1985	157.88	184,085	KITCHEN	
				FLOOR COVER	99	N/A	1.00	C	OPA	N	OPEN PORCH	64		42.70	2,733	BATHS	
				INT FINISH	99	N/A	1.00	D	EPA	N	ENCLOSED PORCH	196		74.40	14,582	HEAT	
				HEATING/COOLING	1	FORCED AIR	1.00	E	WDK	N	WOOD DECK	16		31.63	506	ELECT	
				FUEL SOURCE	2	GAS	1.00	F21	O	FPL 2S 1OP	1		6,819.00	6,819			
				ARPUD	0		1.00										
				AFFORDABLE	0		1.00										
																EFF.YR/AGE	1980 / 41
																COND	27 27 %
																FUNC	0
																ECON	0
																DEPR	27 % GD 73
																RCNLD	\$268,400