

Key: 3615

Town of E. BRIDGEWATER - Fiscal Year 2023

12/6/2022 6:38 pm SEQ #: 3.120

LEG
A
L
L
A
N
D

CURRENT OWNER				PARCEL ID				LOCATION				
SMITH KEVIN E & NANCY A 78 NORTH WATER ST E BRIDGEWATER, MA 02333				81-43-0				78 N WATER ST				
TRANSFER HISTORY				DOS	T	SALE PRICE	BK-PG (Cert)					
SMITH KEVIN E & NANCY A				09/18/1995	QS	127,000	13834-018					
PHILLIPS BARBARA M				06/30/1995	A	1	13669-347					
PHILLIPS JOHN R & BARBARA				05/11/1993	A	1	11847-082					
CD	T	AC/SF/UN	Ngh	Inf1	Inf2	ADJ BASE	SAF	Inf3	Lpi	VC	CREDIT AMT	ADJ VALUE
100	S	24,950 3	1.00	100	1.00	188,000	1.60	100	1.00	3	1.00	171,930

CLASS	CLASS%	DESCRIPTION			BN ID	BN	CARD	
1010	100	SINGLE FAMILY				1	1 of 1	
PMT NO	PMT DT	TY	DESC	AMOUNT	INSP	BY	1st	%
BP-21-130	04/01/2021	3	ALTERATIONS	5,100				0
		6	CYCL GROWTH		12/04/2020	SD		0
		6	CYCL GROWTH		07/10/2013			0

D
E
T
A
C
H
E
D

TOTAL	24,950 SF	ZONING	FRNT	0	ASSESSED	CURRENT	PREVIOUS
Ngh	RES 3	NOTE			LAND	171,900	156,400
Inf1	FACTOR 100		BUILDING	184,200	164,000		
Inf2	PHY 100		DETACHED	2,500	2,300		
			OTHER	0	0		
			TOTAL	358,600	322,700		

TY	QUAL	COND	DIM/NOTE	YB	UNITS	ADJ PRICE	RCNLD
SHF	A	1.00	40 0.60		200	20.44	2,500

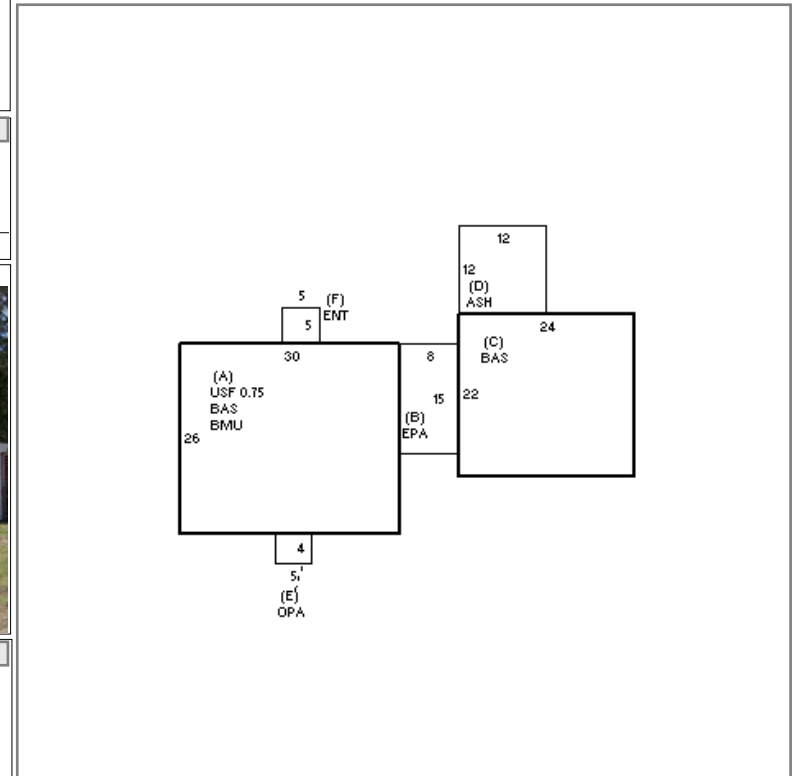

B
U
I
L
D
I
N
G

BUILDING	CD	ADJ	DESC	MEASURE	12/4/2020	SD
MODEL	1		RESIDENTIAL	LIST	12/4/2020	SD
STYLE	4	1.00	CAPE [100%]	REVIEW	4/11/2013	ER
QUALITY	A	1.00	AVERAGE [100%]			
FRAME	1	1.00	WOOD FRAME [100%]			

BLDG COMMENTS

YEAR BLT	1945	SIZE ADJ	1.000	ELEMENT	CD	DESCRIPTION	ADJ	S	BAT	T	DESCRIPTION	UNITS	YB	ADJ PRICE	RCN	TOTAL RCN	368,484													
NET AREA	1,893	DETAIL ADJ	1.020	FOUNDATION	4	CONT BSMT WALL	1.00	A	BMU	N	BSMT UNFINISHED	780		41.99	32,750															
\$NLA(RCN)	\$195	OVERALL	1.000	EXT COVER	1	WD SHINGLES	1.00	A	USF	L	UPPER STORY FIN	585	1945	156.62	91,624															
CAPACITY				ROOF SHAPE	1	GABLE	1.00	B	EPA	N	ENCLOSED PORCH	120		74.40	8,928															
STORIES	1.75		1.00	ROOF COVER	1	ASPH SHINGLES	1.00	+	BAS	L	BASE AREA	1,308	1945	172.35	225,438															
ROOMS	7		1.00	FLOOR COVER	99	N/A	1.00	D	ASH	N	ATT SHED	144		18.75	2,700															
BEDROOMS	3		1.00	INT FINISH	99	N/A	1.00	E	OPA	N	OPEN PORCH	20		42.70	854															
BATHROOMS	2		1.00	HEATING/COOLING	2	HOT WATER	1.02	F	ENT	N	ENCLOSED ENTRY	25		81.12	2,028															
# 1/2 BATHS	0		1.00	FUEL SOURCE	99	N/A	1.00																							
TOT FIXTURES	6	\$4,162		ARPUD	0		1.00																							
# UNITS	1	1.00		AFFORDABLE	0		1.00																							
<table border="1"> <thead> <tr> <th>CONDITION ELEM</th> <th>CD</th> </tr> </thead> <tbody> <tr> <td>EXTERIOR</td> <td></td> </tr> <tr> <td>INTERIOR</td> <td></td> </tr> <tr> <td>KITCHEN</td> <td></td> </tr> <tr> <td>BATHS</td> <td></td> </tr> <tr> <td>HEAT</td> <td></td> </tr> <tr> <td>ELECT</td> <td></td> </tr> </tbody> </table>																CONDITION ELEM	CD	EXTERIOR		INTERIOR		KITCHEN		BATHS		HEAT		ELECT		
CONDITION ELEM	CD																													
EXTERIOR																														
INTERIOR																														
KITCHEN																														
BATHS																														
HEAT																														
ELECT																														
<table border="1"> <thead> <tr> <th>EFF.YR/AGE</th> <td colspan="2">1958 / 63</td> </tr> </thead> <tbody> <tr> <td>COND</td> <td>50</td> <td>50 %</td> </tr> <tr> <td>FUNC</td> <td>0</td> <td></td> </tr> <tr> <td>ECON</td> <td>0</td> <td></td> </tr> <tr> <td>DEPR</td> <td>50</td> <td>% GD 50</td> </tr> </tbody> </table>																EFF.YR/AGE	1958 / 63		COND	50	50 %	FUNC	0		ECON	0		DEPR	50	% GD 50
EFF.YR/AGE	1958 / 63																													
COND	50	50 %																												
FUNC	0																													
ECON	0																													
DEPR	50	% GD 50																												
<table border="1"> <thead> <tr> <th>RCNLD</th> <td>\$184,200</td> </tr> </thead> </table>																RCNLD	\$184,200													
RCNLD	\$184,200																													