

Key: 3697

Town of E. BRIDGEWATER - Fiscal Year 2023

12/6/2022 6:38 pm SEQ #: 3.197

LEGAL

LAND

DETACHED

BUILDING

CURRENT OWNER				PARCEL ID				LOCATION			
FORTES ALCIDES & AMELIA 225 ELM ST E BRIDGEWATER, MA 02333				82-58-0				225 ELM ST			
TRANSFER HISTORY				DOS	T	SALE PRICE		BK-PG (Cert)			
FORTES ALCIDES & AMELIA				07/09/1985	QS	6188-244		6188-244			
WILLIAMS JEAN & LEE				08/14/1981	QS	5039-290		5039-290			

CLASS	CLASS%	DESCRIPTION			BN ID	BN	CARD	
1010	100	SINGLE FAMILY				1	1 of 1	
PMT NO	PMT DT	TY	DESC	AMOUNT	INSP	BY	1st	%
BP-19-163	05/01/2019	6	CYCL GROWTH		06/07/2021	SD	0	0
2133	07/30/2014	3	ALTERATIONS	5,289			0	0
		3	ALTERATIONS	9,000			0	0
342	06/10/2008	6	CYCL GROWTH		07/09/2013	LF	0	0
		3	ALTERATIONS	8,000	06/25/2008		0	0

CD	T	AC/SF/UN	Ngh	Infl1	Infl2	ADJ BASE	SAF	Infl3	Lpi	VC	CREDIT AMT	ADJ VALUE
100	S	35,574 3	1.00	100	100	188,000	1.18	100	1.00	3	1.00	181,110

TOTAL	35,589 SF	ZONING	FRNT	0	ASSESSED	CURRENT	PREVIOUS
Ngh	RES 3	N O T E	LOT 2/ T 14078		LAND	181,100	164,700
Infl1	FACTOR 100		BUILDING	338,400	292,900		
Infl2	PHY 100		DETACHED	16,200	15,400		
			OTHER	0	0		
					TOTAL	535,700	473,000

TY	QUAL	COND	DIM/NOTE	YB	UNITS	ADJ PRICE	RCNLD
SHF	A	1.00	30 0.70		300	18.50	3,900
IPV	A	1.00	10 0.90	19X39	2007	18.49	12,300

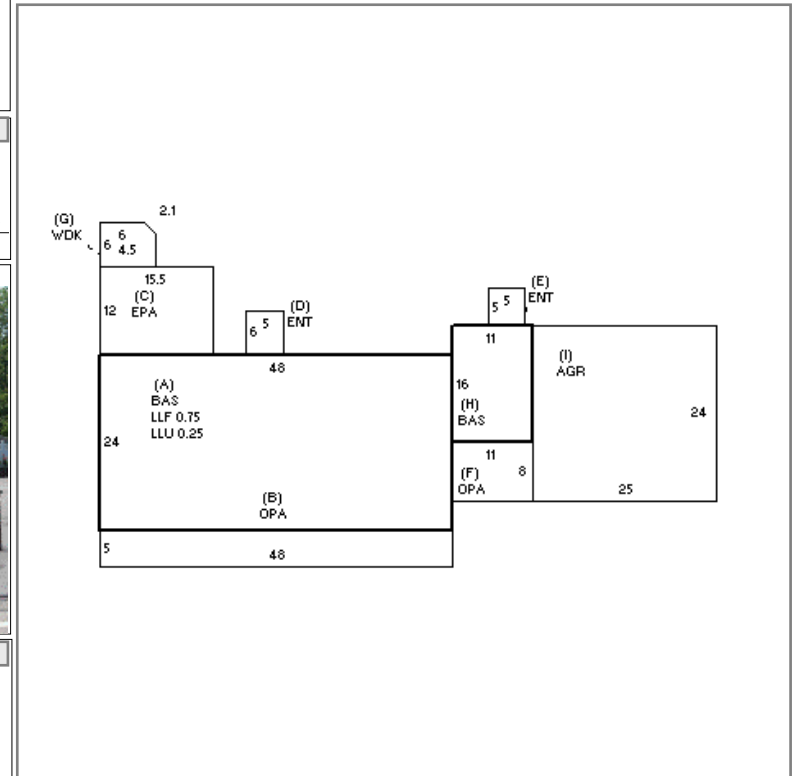

BUILDING	CD	ADJ	DESC	MEASURE	6/7/2021	SD
MODEL	1		RESIDENTIAL	LIST	6/7/2021	SD
STYLE	2	1.05	RAISED RANCH [100%]	REVIEW	4/12/2013	ER
QUALITY	A	1.00	AVERAGE [100%]	BLDG COMMENTS		
FRAME	1	1.00	WOOD FRAME [100%]	IN-LAW APT		

YEAR BLT	1985	SIZE ADJ	1.000	ELEMENT	CD	DESCRIPTION	ADJ	S	BAT	T	DESCRIPTION	UNITS	YB	ADJ PRICE	RCN	TOTAL RCN	445,264		
NET AREA	1,328	DETAIL ADJ	1.081	FOUNDATION	4	CONT BSMT WALL	1.00	A	LLU	N	LOWER LEVEL UNF	288		62.10	17,884	CONDITION ELEM CD			
\$NLA(RCN)	\$335	OVERALL	1.000	EXT COVER	4	VINYL	1.00	A	LLF	N	LOWER LEVEL FIN	864		120.24	103,889	EXTERIOR			
				ROOF SHAPE	2	HIP	1.00	+	OPA	N	OPEN PORCH	328		42.70	14,006	INTERIOR			
				ROOF COVER	1	ASPH SHINGLES	1.00	C	EPA	N	ENCLOSED PORCH	186		74.40	13,838	KITCHEN			
				FLOOR COVER	99	N/A	1.00	+	ENT	N	ENCLOSED ENTRY	55		81.11	4,461	BATHS			
				INT FINISH	99	N/A	1.00	G	WDK	N	WOOD DECK	44		31.59	1,390	HEAT			
				HEATING/COOLING	9	WARM/COOL AIR	1.03	+	BAS	L	BASE AREA	1,328	1985	167.97	223,068	ELECT			
				FUEL SOURCE	99	N/A	1.00	I	AGR	N	ATT GARAGE	600		67.25	40,351				
				ARPUD	0		1.00	F21	O		FPL 2S 1OP	2		6,819.50	13,639				
				AFFORDABLE	0		1.00	KIT	O		XTRA KITCHEN	1		5,387.00	5,387				
																	EFF.YR/AGE	1990 / 31	
																	COND	24 24 %	
																	FUNC	0	
																	ECON	0	
																	DEPR	24 % GD 76	
																	RCNLD	\$338,400	