

Key: 3776

Town of E. BRIDGEWATER - Fiscal Year 2023

12/6/2022 6:38 pm SEQ #: 3.261

LEGALS

CURRENT OWNER				PARCEL ID				LOCATION			
MANGANIELLO ERNEST S 1671 CENTRAL ST E BRIDGEWATER, MA 02333				86-11-0				1671 CENTRAL ST			
TRANSFER HISTORY				DOS	T	SALE PRICE	BK-PG (Cert)				
MANGANIELLO ERNEST S				04/22/2010	H	230,000	38447-343				
BRENNAN RICHARD K				12/31/1985	QS		6507-101				
WASS JEFFERY W & VIOLA JA				12/31/1984	QS	60,000	5920-0009				

CLASS	CLASS%	DESCRIPTION			BN ID	BN	CARD	
1010	100	SINGLE FAMILY				1	1 of 1	
PMT NO	PMT DT	TY	DESC	AMOUNT	INSP	BY	1st	%
		51	FIELD REVIEW		09/30/2013	LF	0	0
		6	CYCL GROWTH		07/16/2010	SLB	0	0
		6	CYCL GROWTH		01/01/2007		0	0

LAND

CD	T	AC/SF/UN	Ngh	Inf1	Inf2	ADJ BASE	SAF	Inf3	Lpi	VC	CREDIT AMT	ADJ VALUE
100	S	35,000	3	1.00	100	1.00	100	1.00	3	1.00		180,620

TOTAL	35,000 SF	ZONING	FRNT	0	ASSESSED	CURRENT	PREVIOUS
Ngh	RES 3	NOTE PARCEL A/ T 14252	LAND	180,600	164,300		
Inf1	FACTOR 100		BUILDING	139,800	133,800		
Inf2	PHY 100		DETACHED	2,500	2,300		
			OTHER	0	0		
			TOTAL	322,900	300,400		

DETACHED

TY	QUAL	COND	DIM/NOTE	YB	UNITS	ADJ PRICE	RCNLD
SHF	A	1.00	40 0.60		200	20.44	2,500

BLDG COMMENTS							
BUILDING	CD	ADJ	DESC	MEASURE	9/30/2013	LF	
MODEL	1		RESIDENTIAL	LIST			
STYLE	1	1.00	RANCH [100%]	REVIEW	4/12/2013	ER	
QUALITY	A	1.00	AVERAGE [100%]				
FRAME	1	1.00	WOOD FRAME [100%]				

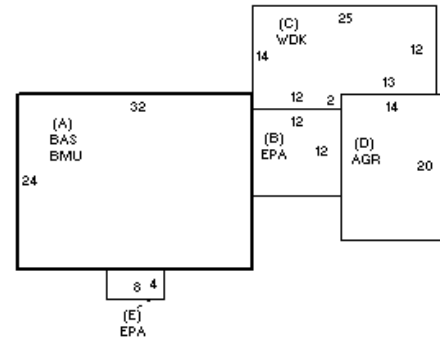
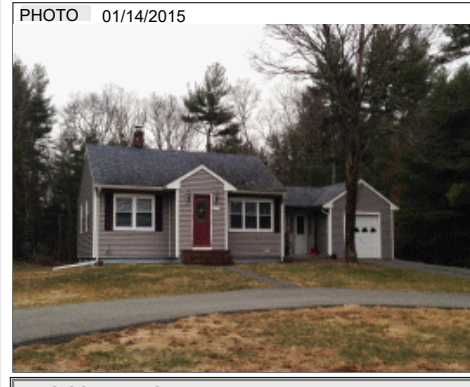

BUILDING

YEAR BLT	1955	SIZE ADJ	1.000
NET AREA	768	DETAIL ADJ	1.020
\$NLA(RCN)	\$364	OVERALL	1.000

CAPACITY			UNITS	ADJ
STORIES	1	1.00		
ROOMS	5	1.00		
BEDROOMS	2	1.00		
BATHROOMS	1	1.00		
# 1/2 BATHS	0	1.00		
TOT FIXTURES	3	\$2,081		
# UNITS	1	1.00		

ELEMENT	CD	DESCRIPTION	ADJ
FOUNDATION	4	CONT BSMT WALL	1.00
EXT COVER	1	WD SHINGLES	1.00
ROOF SHAPE	1	GABLE	1.00
ROOF COVER	1	ASPH SHINGLES	1.00
FLOOR COVER	99	N/A	1.00
INT FINISH	99	N/A	1.00
HEATING/COOLING	2	HOT WATER	1.02
FUEL SOURCE	99	N/A	1.00
ARPUD	0		1.00
AFFORDABLE	0		1.00

S	BAT	T	DESCRIPTION	UNITS	YB	ADJ PRICE	RCN
A	BMU	N	BSMT UNFINISHED	768		42.23	32,433
A	BAS	L	BASE AREA	768	1955	258.17	198,278
+	EPA	N	ENCLOSED PORCH	176		74.40	13,094
C	WDK	N	WOOD DECK	324		31.60	10,238
D	AGR	N	ATT GARAGE	280		83.96	23,509

TOTAL RCN	279,633
CONDITION ELEM	CD
EXTERIOR	
INTERIOR	
KITCHEN	
BATHS	
HEAT	
ELECT	
EFF.YR/AGE	1958 / 63
COND	50 50 %
FUNC	0
ECON	0
DEPR	50 % GD 50
RCNLD	\$139,800