

Key: 4028

Town of E. BRIDGEWATER - Fiscal Year 2023

12/6/2022 6:38 pm SEQ #: 3.484

LEGALS

CURRENT OWNER				PARCEL ID				LOCATION			
LUTHER SANDRA J 304 SUMMER ST E BRIDGEWATER, MA 02333				93-35-0				304 SUMMER ST			
TRANSFER HISTORY				DOS	T	SALE PRICE	BK-PG (Cert)				
LUTHER SANDRA J				05/26/2020	A	100	52801-072				
LUTHER SANDRAJ, STEPHEN M				05/26/2020	A	100	52801-070				
LUTHER CAROLYN R				01/06/2006	A	1	32034-302				

CLASS	CLASS%	DESCRIPTION			BN ID	BN	CARD	
1040	100	TWO FAMILY				1	1 of 1	
PMT NO	PMT DT	TY	DESC	AMOUNT	INSP	BY	1st	%
BP-18-270	08/31/2018	6	CYCL GROWTH		05/04/2021	SD	0	0
		3	ALTERATIONS	8,550			0	0
		6	CYCL GROWTH		07/09/2014	LF	0	0

LAND

CD	T	AC/SF/UN	Ngh	Inf1	Inf2	ADJ BASE	SAF	Inf3	Lpi	VC	CREDIT AMT	ADJ VALUE
100	S	21,700 3	1.00	100	1.00	188,000	1.81	100	1.00	3	1.00	169,130

DETACHED

TOTAL	21,693 SF	ZONING	FRNT	0	ASSESSED	CURRENT	PREVIOUS
Ngh	RES 3	N O T E	T 8094		LAND	169,100	153,800
Inf1	FACTOR 100		BUILDING	160,500	160,200		
Inf2	PHY 100		DETACHED	0	0		
			OTHER	0	0		
TOTAL			329,600	314,000			

TY	QUAL	COND	DIM/NOTE	YB	UNITS	ADJ PRICE	RCNLD	PHOTO	05/14/2021
									

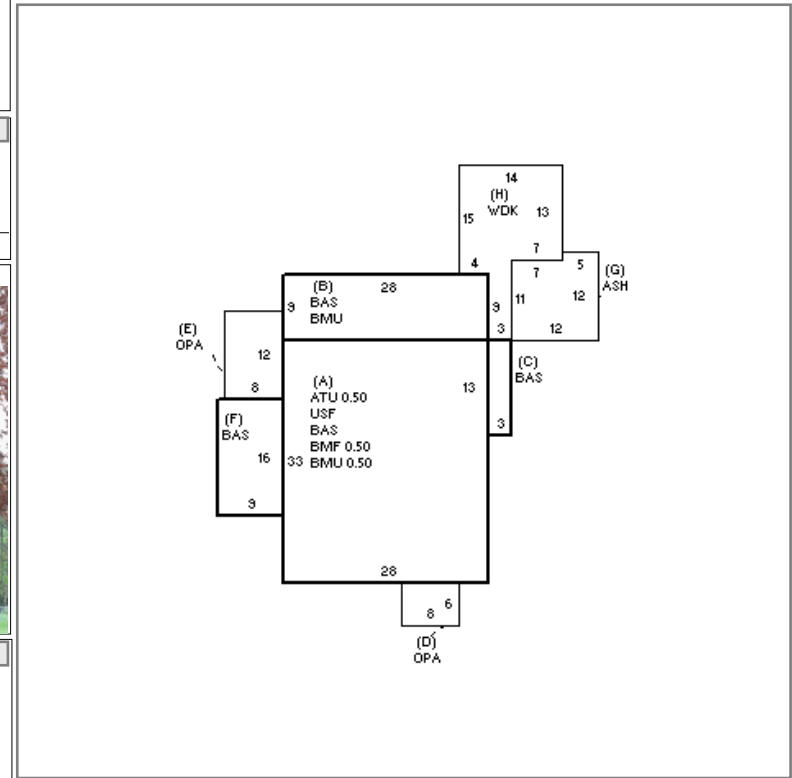

BUILDING

BUILDING	CD	ADJ	DESC	MEASURE	5/4/2021	SD
MODEL	1		RESIDENTIAL	LIST	5/4/2021	SD
STYLE	7	0.90	CONVENTIONAL [100%]	REVIEW	4/15/2013	ER
QUALITY	A	1.00	AVERAGE [100%]			
FRAME	1	1.00	WOOD FRAME [100%]			

YEAR BLT	1830	SIZE ADJ	1.000	ELEMENT	CD	DESCRIPTION	ADJ	S	BAT	T	DESCRIPTION	UNITS	YB	ADJ PRICE	RCN	TOTAL RCN	445,918
NET AREA	2,283	DETAIL ADJ	1.029	FOUNDATION	5	BRICK/STONE	1.00	+	BMU	N	BSMT UNFINISHED	714		37.20	26,560		
\$NLA(RCN)	\$195	OVERALL	1.000	EXT COVER	4	VINYL	1.00	A	BMF	N	BSMT FINISH-SEP	462		52.31	24,169		
				ROOF SHAPE	1	GABLE	1.00	A	USF	L	UPPER STORY FIN	924	1830	148.72	137,417		
				ROOF COVER	1	ASPH SHINGLES	1.00	A	ATU	N	ATTIC UNF	462		30.30	13,999		
				FLOOR COVER	99	N/A	1.00	+	BAS	L	BASE AREA	1,359	1830	163.66	222,410		
				INT FINISH	99	N/A	1.00	+	OPA	N	OPEN PORCH	144		42.70	6,149		
				HEATING/COOLING	11	HW/COOL AIR	1.04	G	ASH	N	ATT SHED	137		18.75	2,569		
				FUEL SOURCE	99	N/A	1.00	H	WDK	N	WOOD DECK	223		31.60	7,047		
				ARPUD	0		1.00										
				AFFORDABLE	0		1.00										

CONDITION ELEM	CD
EXTERIOR	
INTERIOR	
KITCHEN	
BATHS	
HEAT	
ELECT	

EFF.YR/AGE	1951 / 70
COND	64 64 %
FUNC	0
ECON	0
DEPR	64 % GD 36
RCNLD	\$160,500