

Key: 4128

Town of E. BRIDGEWATER - Fiscal Year 2023

12/6/2022 6:38 pm SEQ #: 3.581

LEGALS AND

| CURRENT OWNER | | | | PARCEL ID | | | | LOCATION | | | | |
|---|---|----------|-----|---------------------------|------|------------|------|----------------|--------------|----|------------|-----------|
| PITTSLEY EDWARD S & CATHERINE M | | | | 94-28-0 | | | | 242 BELMONT ST | | | | |
| 242 BELMONT ST E BRIDGEWATER, MA 02333 | | | | TRANSFER HISTORY | | DOS | T | SALE PRICE | BK-PG (Cert) | | | |
| | | | | PITTSLEY EDWARD S & CATHE | | 12/30/2020 | A | 1 (131335) | | | | |
| | | | | PITTSLEY EDWARD S & CATHE | | 05/10/2010 | A | 1 (114622) | | | | |
| | | | | PITTSLEY EDWARD S | | 06/05/1998 | A | 1 0466-085 | | | | |
| CD | T | AC/SF/UN | Ngh | Inf1 | Inf2 | ADJ BASE | SAF | Inf3 | Lpi | VC | CREDIT AMT | ADJ VALUE |
| 100 | S | 24,531 | 3 | 1.00 | 100 | 188,000 | 1.62 | 100 | 1.00 | 3 | 171,580 | |

| CLASS | CLASS% | DESCRIPTION | | | BN ID | BN | CARD | |
|-----------|------------|---------------|--------------|--------|------------|----|--------|---|
| 1010 | 100 | SINGLE FAMILY | | | | 1 | 1 of 1 | |
| PMT NO | PMT DT | TY | DESC | AMOUNT | INSP | BY | 1st | % |
| BP-18-351 | 11/28/2018 | 3 | ALTERATIONS | 4,200 | 01/06/2017 | JH | 0 | 0 |
| | | 6 | CYCL GROWTH | | 08/23/2013 | | 0 | 0 |
| | | 6 | CYCL GROWTH | | | | 0 | 0 |
| 597 | 10/18/2010 | 7 | DETACHED BLD | 2,856 | | | 0 | 0 |

LEGALS AND

| TOTAL | 24,531 SF | ZONING | FRNT | 0 | ASSESSED | CURRENT | PREVIOUS |
|-------|------------|------------------------|----------|---|----------|---------|----------|
| Ngh | RES 3 | NOTE #426798 #93285 | LAND | | 171,600 | 156,100 | |
| Inf1 | FACTOR 100 | | BUILDING | | 196,800 | 181,100 | |
| Inf2 | PHY 100 | | DETACHED | | 1,800 | 1,800 | |
| | | | OTHER | | 0 | 0 | |
| | | | TOTAL | | 370,200 | 339,000 | |

DETACHED

| TY | QUAL | COND | DIM/NOTE | YB | UNITS | ADJ PRICE | RCNLD | PHOTO | 01/06/2017 |
|-----|------|------|---------------|------|-------|-----------|-------|--|------------|
| SHF | A | 1.00 | 10 0.90 10X10 | 2011 | 100 | 20.44 | 1,800 |  | |

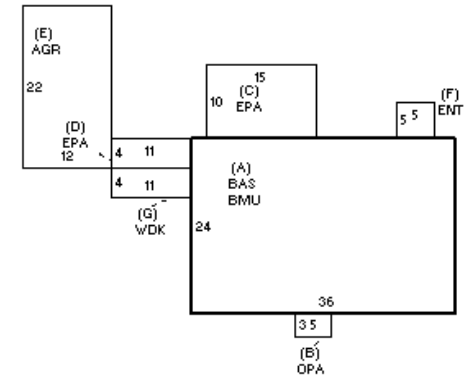

BUILDING

| BUILDING | CD | ADJ | DESC | MEASURE | 1/6/2017 | JH |
|----------|----|------|-------------------|---------|-----------|----|
| MODEL | 1 | | RESIDENTIAL | LIST | | |
| STYLE | 1 | 1.00 | RANCH [100%] | REVIEW | 4/16/2013 | ER |
| QUALITY | A | 1.00 | AVERAGE [100%] | | | |
| FRAME | 1 | 1.00 | WOOD FRAME [100%] | | | |

| YEAR BLT | 1954 | SIZE ADJ | 1.000 | ELEMENT | CD | DESCRIPTION | ADJ | S | BAT | T | DESCRIPTION | UNITS | YB | ADJ PRICE | RCN | TOTAL RCN | 289,481 |
|------------|-------|------------|-------|-----------------|----|----------------|------|---|-----|---|-----------------|-------|------|-----------|---------|-----------|---------|
| NET AREA | 864 | DETAIL ADJ | 1.030 | FOUNDATION | 4 | CONT BSMT WALL | 1.00 | A | BMU | N | BSMT UNFINISHED | 864 | | 40.60 | 35,078 | | |
| \$NLA(RCN) | \$335 | OVERALL | 1.000 | EXT COVER | 3 | ALUMINUM | 1.00 | A | BAS | L | BASE AREA | 864 | 1954 | 244.38 | 211,143 | | |
| | | | | ROOF SHAPE | 1 | GABLE | 1.00 | B | OPA | N | OPEN PORCH | 15 | | 42.73 | 641 | | |
| | | | | ROOF COVER | 1 | ASPH SHINGLES | 1.00 | + | EPA | N | ENCLOSED PORCH | 194 | | 74.40 | 14,434 | | |
| | | | | FLOOR COVER | 99 | N/A | 1.00 | E | AGR | N | ATT GARAGE | 264 | | 85.86 | 22,666 | | |
| | | | | INT FINISH | 99 | N/A | 1.00 | F | ENT | N | ENCLOSED ENTRY | 25 | | 81.12 | 2,028 | | |
| | | | | HEATING/COOLING | 9 | WARM/COOL AIR | 1.03 | G | WDK | N | WOOD DECK | 44 | | 31.59 | 1,390 | | |
| | | | | FUEL SOURCE | 2 | GAS | 1.00 | | | | | | | | | | |
| | | | | ARPUD | 0 | | 1.00 | | | | | | | | | | |
| | | | | AFFORDABLE | 0 | | 1.00 | | | | | | | | | | |

| CONDITION ELEM | CD |
|----------------|----|
| EXTERIOR | |
| INTERIOR | |
| KITCHEN | |
| BATHS | |
| HEAT | |
| ELECT | U |

| | |
|------------|------------|
| EFF.YR/AGE | 1970 / 51 |
| COND | 32 32 % |
| FUNC | 0 |
| ECON | 0 |
| DEPR | 32 % GD 68 |
| RCNLD | \$196,800 |